

Certificate

Certified Passive House Component

for cool, temperate climates; valid until 31.12.2013

Passive House Institute
Dr. Wolfgang Feist
64283 Darmstadt
GERMANY

Category: **Window Frame**
 Manufacturer: **Casagrande Woodworks, Inc.**
Paso Robles, CA 93446, USA
 Product name: **Synergist**

This certificate was awarded based on the following criteria:

Given a U_g value of $0.70 \text{ W}/(\text{m}^2\text{K})$ and a window size of 1.23 m by 1.48 m,

$$U_w = 0.79 \text{ W}/(\text{m}^2\text{K}) \leq 0.80 \text{ W}/(\text{m}^2\text{K})$$

Taking into account the installation based thermal bridges and provided that the installation is, with regard to the thermal bridges, equal or better than shown in the data sheet, the window meets the following criterion.

$$U_{w,\text{installed}} \leq 0.85 \text{ W}/(\text{m}^2\text{K})$$

Thermal data

	U_f -value [W/(m ² K)]	Width [mm]	Ψ_g [W/(mK)]	$f_{Rsi=0.25}$ [-]
Spacer			Swisspacer Ultimate*	
Bottom	0.84	98	0.020	0.70
Side/top	0.84	98	0.020	

*Spacers of lower thermal quality, especially those made of aluminium, lead to significantly higher thermal losses and lower temperature factors.

For further information, please see the data sheet

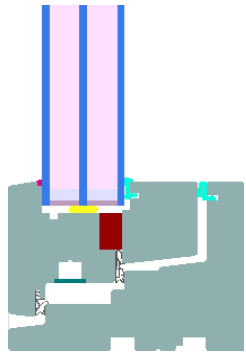

Passive House Efficiency Class

phA
advanced component

phB
basic component

phC
certifiable component

not suitable for Passive Houses



phA

CERTIFIED COMPONENT

Passive House Institute

Data Sheet Casagrande Woodworks, Inc., Synergist

Manufacturer Casagrande Woodworks, Inc.
 4230 Cloud Way, Paso Robles, CA 93446, USA
 Tel.: + 1 805 226 2040
 Email: Jeff@casagrandewoodworks.com, www.casagrandewoodworks.com

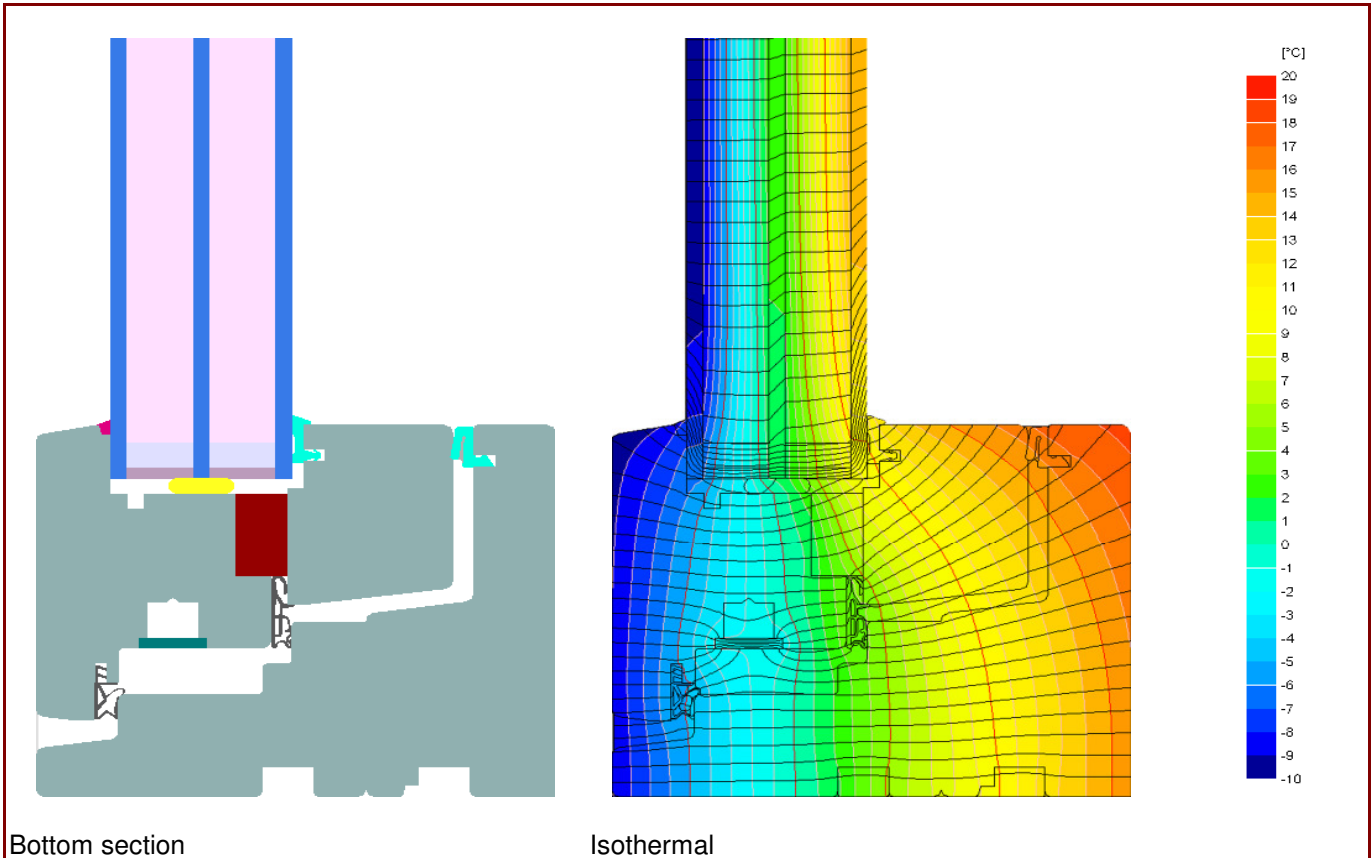

Description

Timber window frame (spruce, fir 0,11 W/(mK)) with cork insulation in the frame and Spaceloft (0,016 W/(mK)) in the glazing rebate. Secondary seal: Butyl (0,24 W/(mK)). Pane thickness: 44 mm (4/16/4/16/4), Rebate depth: 15 mm.

Thermal data for the window frame

	U_f -value [W/(m ² K)]	Width [mm]	Ψ_g [W/(mK)]	$f_{Rsi=0.25}$ [-]
Spacer	Swisspacer Ultimate*			0.70
Bottom	0.84	98	0.020	
Side/Top	0.84	98	0.020	
Flying Mullion	0.84	144	0.020	0.71

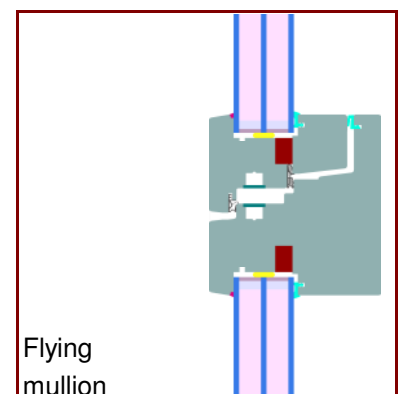

* Spacers of lower thermal quality lead to higher thermal losses and lower glass edge temperatures.

Data Sheet Casagrande Woodworks, Inc., Synergist

Installation

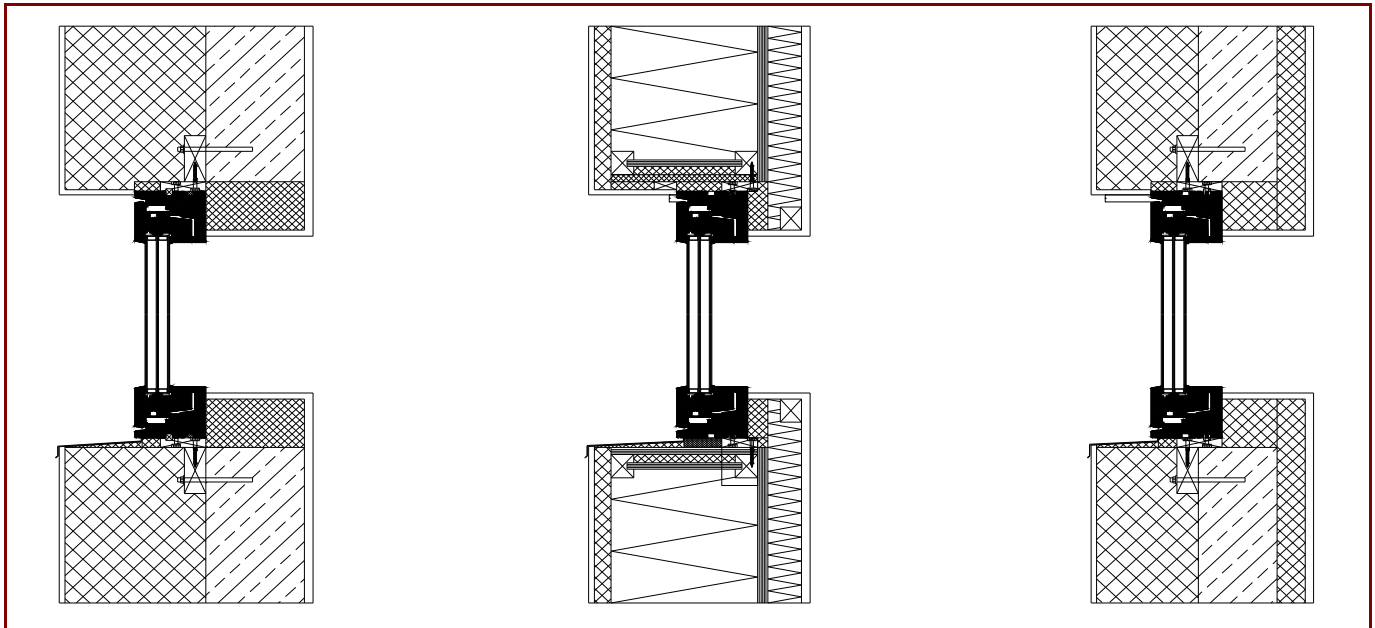

Installation based thermal bridge $\Psi_{\text{instal.}}$ in Passive House suitable walls

		EIFS	Timber construction wall	Insulated formwork blocks
Position				
Bottom	[W/(mK)]	0.017	0.009	0.016
Side/Top	[W/(mK)]	0.005	-0.001	0.009
$U_{W,\text{instal.}}$	[W/(m ² K)]	0.81	0.79	0.82

Explanatory notes

The window U-values were calculated based on a 1.23 m by 1.48 m window $U_g = 0.70 \text{ W}/(\text{m}^2\text{K})$.
If better glazing is used, the window U-values decrease as follows:

U Glazing	U_g [W/(m²K)]	0.64	0.58	0.54
U Window	U_w [W/(m²K)]	0.75	0.70	0.67

Depending on the thermal losses through opaque elements, transparent components are categorised according to efficiency classes. These thermal losses include the losses through the frame, the frame width, the thermal bridge at the glass edge as well as the length of the glass edge. Certificates for arctic regions are too valid vor cold, certificates for cold regions are too valid for cool, temperate zones.

Please ask the manufacturer for a detailed report containing all calculations and results.
For further information, please visit www.passivehouse.com or www.passipedia.org.