

Solar Energy Related Provisions in the 2012 I-Codes

- ❖ Note: Italicized text preceded by this symbol in this document is excerpted from ICC code commentaries. This text was taken from preliminary documents and may not reflect final commentary text.

Although the code sections herein are typically directly related to solar installations, many other code sections may also be applicable to solar energy systems.

Many of the sections included herein cannot stand, or be interpreted, on their own and must be evaluated in the context of other code sections such as, but not limited to, their parent sections.

This document was compiled based on simple word searches and may not be comprehensive. If you find other requirements that should be added, please notify staff.

Please do not circulate this information to others outside of the SEHPCAC Solar Task Group.

All information is copyrighted by the International Code Council, 2012.

1. 2012 *International Building Code (IBC)*:

Section 202 Definitions

Photovoltaic modules/shingles. A roof covering composed of flat-plate photovoltaic modules fabricated in sheets that resemble three-tab composite shingles.

- ❖ *This definition provides clarification of roof covering requirements that appear in Section 1507.17.*

1505.8 Photovoltaic systems. Rooftop installed photovoltaic systems that are adhered or attached to the roof covering or photovoltaic modules/shingles installed as roof coverings shall be labeled to identify their fire classification in accordance with the testing required in Section 1505.1.

- ❖ *The minimum requirement set forth here establishes that the rooftop photovoltaic system should comply with the same minimum fire classification requirements as the underlying roof assembly.*

1507.17. Photovoltaic modules/shingles. The installation of photovoltaic modules/shingles shall comply with provisions of this section.

- ❖ *This section provides guidance for the installation of photovoltaic modules/shingles. These shingles are integrated with the building and provide both a roof covering and source of electrical power.*

1507.17.1 Material standards. Photovoltaic modules/shingles shall be listed and labeled in accordance with UL 1703.

- ❖ *This section references UL 1703 as the standard used for determining code compliance of photovoltaic modules/shingles.*

1507.17.2 Attachment. Photovoltaic modules/shingles shall be attached in accordance with the manufacturer's installation instructions.

- ❖ *Referring to the manufacturer's instructions is appropriate since the required slope and fastening of the photovoltaic modules/shingles are different for each manufacturer's product.*

1507.17.3 Wind resistance. Photovoltaic modules/shingles shall be tested in accordance with procedures and acceptance criteria in ASTM D3161. Photovoltaic modules/shingles shall comply with the classification requirements of Table 1507.2.7.1(2) for the appropriate maximum nominal design wind speed. Photovoltaic module/shingle packaging shall bear a label to indicate compliance with the procedures in ASTM D3161 and the required classification from Table 1507.2.7.1(2).

- ❖ *For wind resistance, the procedures and acceptance criteria used in ASTM D3161 for asphalt shingles are appropriate when adapted for photovoltaic modules/shingles.*

1509.7 Photovoltaic systems. Rooftop mounted photovoltaic systems shall be designed in accordance with this section.

- ❖ *Rooftop-mounted photovoltaic systems need to comply with building code requirements similar to other rooftop structures.*

1509.7.1 Wind resistance. Rooftop mounted photovoltaic systems shall be designed for wind loads for component and cladding in accordance with Chapter 16 using an effective wind area based on the dimensions of a single unit frame.

- ❖ *This section clarifies that rooftop-mounted photovoltaic systems need to resist components and cladding wind loads and specifies that a single unit must be used to establish the effective wind area.*

1509.7.2 Fire classification. Rooftop mounted **photovoltaic systems** shall have the same fire classification as the roof assembly required by Section 1505.

- ❖ *The minimum requirements set forth here are intended for the rooftop-mounted **photovoltaic system** to comply with the same minimum requirements as the underlying roof assembly.*

1509.7.3 Installation. Rooftop mounted **photovoltaic systems** shall be installed in accordance with the manufacturer's installation instructions

- ❖ *Rooftop-mounted **photovoltaic** systems need to be installed in accordance with the manufacturer's instructions.*

1509.7.4 Photovoltaic panels and modules. Photovoltaic panels and modules mounted on top of a roof shall be listed and labeled in accordance with UL 1703 and shall be installed in accordance with the manufacturer's installation instructions.

- ❖ *This section addresses the safety of **photovoltaic panels and modules** by requiring these products to comply with UL 1703 and to be installed in accordance with the manufacturer's instructions. UL 1703 is a standard used to investigate **photovoltaic modules and panels** and includes construction and performance requirements that address potential safety hazards.*

1511.1 Solar Photovoltaic Panels/Modules. Solar photovoltaic panels/modules installed upon a roof or as an integral part of a roof assembly shall comply with the requirements of this code and the International Fire Code.

- ❖ *Roof-mounted **solar photovoltaic panels/modules** should comply with roofing requirements, such as supporting the load of these systems on roofs and structural framing. This section also makes a needed reference to relevant requirements in the IFC.*

1511.1.1 Structural fire resistance. The structural frame and roof construction supporting the load imposed upon the roof by the **photovoltaic panels/modules** shall comply with the requirements of Table 601.

- ❖ *This section is a reminder to verify compliance with Table 601 for the portion of the structure that supports the additional load of roof-mounted **solar photovoltaic panels/modules**.*

2606.12 Solar collectors. Light-transmitting plastic covers on **solar collectors** having noncombustible sides and bottoms shall be permitted on buildings not over three stories above grade plane or 9,000 square feet (836.1 m²) in total floor area, provided the light-

transmitting plastic cover does not exceed 33.33 percent of the roof area for CC1 materials or 25 percent of the roof area for CC2 materials.

Exception: Light-transmitting plastic covers having a thickness of 0.010 inch (0.3 mm) or less or shall be permitted to be of any plastic material provided the area of the **solar collectors** does not exceed 33.33 percent of the roof area.

- ❖ *Approved light-transmitting plastic can be used for **solar collector** covers that meet the requirements of Section 2606.12. Basically, the size and height of the building is limited and depending on the combustibility two different maximums are provided. Any plastic material may be used as **solar collector** covers provided that the cover thickness does not exceed 0.010 inch (0.254 mm) and the collector does not exceed 33.33 percent of the roof area. Essentially the fire hazard only exists on the roof which poses minimal threats initially to occupants.*

3111 **Solar photovoltaic panels/modules**

3111.1 General. **Solar photovoltaic panels/modules** shall comply with the requirements of this code and the International Fire Code.

- ❖ **Photovoltaic arrays** are increasing in popularity as an alternative energy source. These arrays, which cannot be shut down and retain electrical charges present unique hazards to fire fighters operating on roofs with arrays or nearby circuits. This section references the IFC, which provides general requirements to allow for increased safety of fire fighters working around and near the arrays.

2. 2012 **International Energy Conservation Code (IECC):**

C402.2.1.1 Roof solar reflectance and thermal emittance. C402.2.1.1 Roof solar reflectance and thermal emittance. Low-sloped roofs, with a slope less than 2 units vertical in 12 horizontal, directly above cooled conditioned spaces in Climate Zones 1, 2, and 3 shall comply with one or more of the options in Table C402.2.1.1.

Exceptions: The following roofs and portions of roofs are exempt from the requirements in Table C402.2.1.1:

1. Portions of roofs that include or are covered by:
 - 1.1. Photovoltaic systems or components.
 - 1.2. **Solar** air or water heating systems or components.
 - 1.3. Roof gardens or landscaped roofs.
 - 1.4. Above-roof decks or walkways.
 - 1.5. Skylights.
 - 1.6. HVAC systems, components, and other opaque objects mounted above the roof.
2. Portions of roofs shaded during the peak sun angle on the summer solstice by permanent features of the building, or by permanent features of adjacent buildings.
3. Portions of roofs that are ballasted with a minimum stone ballast of 17 pounds per square foot (psf) (74 kg/m²) or 23 psf (117 kg/m²) pavers.
4. Roofs where a minimum of 75 percent of the roof area meets a minimum of one of the exceptions above.

- ❖ *This section of the code requires low-sloped roofs directly above cooled conditioned spaces in climate zones 1,2 and 3 to comply with one or more options in Table C402.2.1.1. Exceptions are for roofs that have photovoltaic systems or components, solar air or water heating systems, gardens or landscaping, skylights, HVAC system components and other opaque objects mounted on the roof. Also exempt are portions of the roof shaded during the peak sun angle on the summer solstice by permanent features of the building, or by permanent features of adjacent buildings. Another exception to this code section is roofs with a minimum of 75 percent of the roof area.*

Cool roofs are important in reducing the cooling load in a building with low slope roofs in Climate Zones 1, 2 and 3 where the temperature is hot. A cool roof is a roofing system that can deliver high solar reflectance, which is the ability to reflect the visible, infrared and ultraviolet wavelengths of the sun, reducing the heat transfer to the building, and high thermal emittance, which is the ability to radiate absorbed, or non-reflected solar energy. Cool roofs can reduce the building heat-gain and cooling loads. It can help reduce the urban heat island defect. Cool roofs offer both immediate and long term savings in building energy costs by enhancing the life expectancy of the roof membrane and buildings' cooling equipment by reducing the building's heat gain.

C403.2.6 Energy recovery ventilation systems. Where the supply airflow rate of a fan system exceeds the values specified in Table C403.2.6, the system shall include an energy recovery system. The energy recovery system shall have the capability to provide a change in the enthalpy of the outdoor air supply of not less than 50 percent of the difference between the outdoor air and return air enthalpies, at design conditions. Where an air economizer is required, the energy recovery system shall include a bypass or controls which permit operation of the economizer as required by Section C403.4

Exception: An energy recovery ventilation system shall not be required in any of the following conditions:

1. Where energy recovery systems are prohibited by the International Mechanical Code.
2. Laboratory fume hood systems that include at least one of the following features:
 - 2.1 Variable-air-volume hood exhaust and room supply systems capable of Reducing exhaust and makeup air volume to 50 percent or less of design values.
 - 2.2 Direct makeup (auxiliary) air supply equal to at least 75 percent of the Exhaust rate, heated no warmer than 2°F (1.1°C) above room setpoint, Cooled to no cooler than 3°F (1.7°C) below room setpoint, no humidification added, and no simultaneous heating and cooling used for dehumidification control.
3. Systems serving spaces that are heated to less than 60°F (15.5°C) and are not cooled.
4. Where more than 60 percent of the outdoor heating energy is provided from site-recovered or site solar energy.
5. Heating energy recovery in Climate Zones 1 and 2.
6. Cooling energy recovery in Climate Zones 3C, 4C, 5B, 5C, 6B, 7 and 8.

7. Systems requiring dehumidification that employ energy recovery in series with the cooling coil.
8. Where the largest source of air exhausted at a single location at the building exterior is less than 75 percent of the design *outdoor air* flow rate.
9. Systems expected to operate less than 20 hours per week at the *outdoor air* percentage covered by Table C403.2.6

- ❖ *This section provides a threshold requirement for the mandatory use of energy recover ventilation (ERV) systems. The code requires the energy recovery system to have the capability to provide a change in the enthalpy of the outdoor air supply of not less than 50 percent of the difference between the outdoor air and return air enthalpies, at design conditions. Permeable and nonpermeable plate-type heat exchangers, heat pipes, run-around loops and enthalpy wheels are used to meet this requirement. There are a number of exceptions to this requirement.*

Requirements for outdoor ventilation air rates in ASHRAE 62, and subsequently the model codes have increased over recent years. This has placed new demands on HVAC equipment and operating budgets for buildings. New ozone-friendly refrigerants have also reduced equipment capacity. These conditions have increased the value of energy recovery in ventilation systems. ERV reduces the load on the system caused by outdoor air by taking advantage of the work that has been done to heat, cool, humidify or dehumidify a space. Instead of losing that energy to the atmosphere when air is exhausted, a portion of the energy is recovered and used to pretreat incoming outdoor air, thus reducing the loads on the HVAC system. ERV systems are particularly effective in this application. Studies indicate this would result in a 15-percent reduction of the total energy used in commercial heating, refrigeration, ventilation and air conditioning.

The provisions and the exceptions all define the boundary conditions within which mandatory requirement for application of ERV technology is justified. There are several different types of ERV systems that are provided by a variety of manufacturers and suppliers. The provisions, however, are generic in that they treat all ERV systems the same without being specific or limiting as to type. Not all ERV system types are equally efficient, but under the conditions and limitations in the code, all system types will accomplish the objective of substantial energy efficiency.

Exception 1, referencing the IMC, correlates with prohibitions found in the IMC. This will prohibit the use of ERV systems in hazardous exhaust systems and commercial kitchen hoods. The code must not require ERV in those exhaust systems in order to avoid a conflict between the IMC and code. Not all laboratory fume hoods are hazardous exhaust systems. These exceptions for laboratory fume hoods are therefore appropriate and do not pose any conflict with Exception 1 since any laboratory fume hood that is a hazardous exhaust system would be prohibited by Exception 1 and the IMC from having an ERV system. Systems that are expected to operate less than 20 hours per week at the outdoor percentage covered by Table C403.2.6 are exempt.

C403.4.5 Requirements for complex mechanical systems serving multiple zones.

Sections C403.4.5.1 through C403.4.5.3 shall apply to complex mechanical systems serving multiple zones. Supply air systems serving multiple zones shall be VAV systems which, during multiple zones shall be VAV systems which, during periods of occupancy, are designed and capable of being controlled to reduce primary air supply to each zone to one of the following before reheating, recooling or mixing takes place:

1. Thirty percent of the maximum supply air to each zone.
2. Three hundred cfm (142 L/s) or less where the maximum flow rate is less than 10 percent of the total fan system supply airflow rate.
3. The minimum ventilation requirements of Chapter 4 of the International Mechanical Code.

Exceptions: The following define where individual zones or where entire air distribution systems are exempted from the requirement for VAV control:

1. Zones where special pressurization relationships or cross-contamination requirements are such that VAV systems are impractical.
2. Zones or supply air systems where at least 75 percent of the energy for reheating or for providing warm air in mixing systems is provided from a site-recovered or site-solar energy source.
3. Zones where special humidity levels are required to satisfy process needs.
4. Zones with a peak supply air quantity of 300 cfm (142 L/s) or less and where the flow rate is less than 10 percent of the total fan system supply airflow rate.
5. Zones where the volume of air to be reheated, recooling or mixed is no greater than the volume of outside air required to meet the minimum ventilation requirements of Chapter 4 of the International Mechanical Code.
6. Zones or supply air systems with thermostatic and humidistatic controls capable of operating in sequence the supply of heating and cooling energy to the zones and which are capable of preventing reheating, recooling, mixing or simultaneous supply of air that has been previously cooled, either mechanically or through the use of economizer systems, and air that has been previously mechanically heated.

- ❖ *When air-conditioning system designs were developed in the late 1950s and early 1960s, energy costs were a minor concern. The systems were designed primarily for precise temperature control with little regard for energy costs. Zone temperature control was achieved by reheating cold supply air (constant volume reheat system) recooling warm supply air (such as perimeter induction systems) or mixing hot and cold air (constant volume dual-duct and multi-zone system). Although these systems provided fine temperature control, they did so at great expense of energy.*

To curb the use of these wasteful energy design practices, Section C403.4.5 requires systems serving multiple zones to be VAV systems equipped with zone thermostatic and humidistat controls designed and specifically capable of sequencing the supply of heating and cooling energy to each zone to a minimum before reheating, recooling, or mixing takes place. The requisite controls must thereby minimize:

- *Reheating*
- *Recooling*
- *Mixing or simultaneous supply of air that has been previously mechanically heated and air that has been previously cooled, either mechanically or by economizer systems.*

The three items listed in the section establish what level of air supply must be reached before it is permissible for the system to either reheat, recool or mix heated and cooled air.

There are six exceptions that address when either individual zones or the entire air distribution system are exempt from the VAV requirement or controls affecting the simultaneous heating and cooling requirements.

Exception 1 covers zones where special pressurization relationships, minimum circulation rates or cross-contamination requirements make VAV systems impractical. This exception might apply to some areas of hospitals, such as operating and isolation rooms, morgues and laboratories, which must be maintained at positive (or negative) pressures to prevent contaminants from entering (or escaping). VAV systems have been successfully used in these applications in an effort to reduce energy costs, but control is very complicated and requires precise airflow and pressure measuring instruments. The risk of a failure of these controls, such as the possible release of dangerous chemicals, bacteria or contagions, may not be worth the potential energy savings.

*Exception 2 covers zones or systems where at least 75 percent of the energy for reheating or producing warm air supply in mixing systems is supplied by heat recovered from some process or equipment within the building (such as chiller condenser heat) or from a **solar heating system** installed on site.*

Exception 3 acknowledges zones where specific humidity levels must be maintained for purposes other than personal comfort, such as some areas of museums or archives where sensitive materials are displayed or stored, or some computer rooms where equipment must be maintained within precise humidity ranges to function properly. Note that much of the computer equipment manufactured today, such as common person computers and most minicomputers, does not require this precise humidity control, so this exception would not apply.

For typical multiple-zone systems, Exception 4 can be applied to, at best, a limited number of zones served by the system. The exception applies to zones with a peak supply air quantity of 300 cfm (142 L/s) or less and also where the flow rate is less than 10 percent of the total fan system supply airflow rate.

This criterion was included specifically to address reheat systems and heating problems that can occur within small zones or subzones that have low peak supply air volumes, but a larger zone requires additional heat, such as spaces with large glass areas facing north or shaded by overhangs and fins or entry vestibules. These spaces can often require higher heating volumes than allowed by Exception 5 using reasonable supply air temperatures. In most cases 300 cfm (142 L/s) will be sufficient for heating. If not, a fan-powered VAV box could be used to improve the circulation rate.

The exception allows reheat to be used for small subzones of a larger zone. For instance, an air conditioner might serve an office space in which more heat is needed at the front entry area to offset infiltration when exterior doors are opened. If the supply to the entry is less than 300 cfm (142 L/s) a reheat coil may be installed to meet this special heating requirement.

Exception 5 is most common for multiple-zone systems. In this case, the VAV control strategy could also reduce the airflow to each zone that is being reheated, re-cooled, or mixed to a minimum rate that does not exceed the volume required to meet the minimum ventilation requirements of Chapter 4 of the IMC. A conservative interpretation of this IMC chapter might lead to very high minimum flow rates to guarantee each zone receives minimum outside air regardless of the percentage of outside air brought in at

the system level. Instead, to reduce energy costs and first costs, the designer could take advantage of direct transfer of air from adjacent over ventilated zones.

Simultaneous heating and cooling is allowed by Exception 6 if it is minimized by use of VAV controls.

Although there is little empirical evidence and no code-related requirement, many designers feel that a minimum supply air circulation rate of 0.4 cfm/ft³ [(0.002032 m³/(s × m²))] of the zone conditioned floor area must be maintained for comfort. In fact, ASHRAE 55 (a standard for thermal environmental conditions for human occupancy) states there is no minimum air velocity required for comfort. Nevertheless, with little or no air movement, some designers feel occupants will complain of stuffiness. Moreover, typical air outlet performance drops off at low flows, reducing its ability to effectively mix supply air with room air. This is a particular problem with reheat boxes because the supply air temperature at the minimum volume will be warm and the buoyancy of the supply air will further decrease mixing unless the outlet velocities are maintained.

As in Exception 6, single-zone (simple) systems, with controls interlocked or otherwise capable of sequencing typical heating and cooling, will inherently meet these requirements. But most common multiple-zone (complex) systems require the use of simultaneous heating and cooling for zone temperature control.

C403.4.5.4 Supply-air temperature reset controls. Multiple zone HVAC systems shall include controls that automatically reset the supply-air temperature in response to representative building loads, or to outdoor air temperature. The controls shall be capable of resetting the supply air temperature at least 25 percent of the difference between the design supply-air temperature and the design room air temperature.

Exceptions:

1. Systems that prevent reheating, re-cooling or mixing of heated and cooled supply air.
2. Seventy five percent of the energy for reheating is from site-recovered or site solar energy sources.
3. Zones with peak supply air quantities of 300 cfm (142 L/s) or less.

❖ *The purpose of this section of the code is to require supply-air temperature reset controls on multiple-zone systems. Multiple-zone HVAC systems typically deliver supply air at a constant temperature necessary to provide cooling for a zone with the worst case peak cooling load. Any zone requiring less cooling than this must reduce the amount of cool air to that zone (if a VAV system) and eventually reheat that cool air if necessary to prevent zone overcooling. This is known as simultaneous heating and cooling. Building control systems can easily incorporate logic and controls that continually poll the various zones and raise the supply air temperature as high as possible while still satisfying the cooling demand. This reduces the necessity for simultaneous heating and cooling and saves energy. Systems that prevent reheating, recooling or mixing of heated and cooled supply air are exempt, as they cannot benefit by the addition of supply-air temperature reset controls. Seventy five percent of the energy from site-recovered or site solar energy sources for reheating would be exempt, as the controls installed should be capable of resetting the supply-air temperature at least 25 percent of the difference between the design supply-air temperature and the design room air temperature, and that would be marginal. For zones with peak supply air quantities of 300 cfm (0.14 m³/s) or less, it would not be*

cost effective to install supply-air temperature reset controls, as the supply air is a small quantity compared to the building load.

C403.4.6 Heat recovery for service water heating. Condenser heat recovery shall be installed for heating or reheating of service hot water provided the facility operates 24 hours a day, the total installed heat capacity of water-cooled systems exceeds 6,000,000 Btu/hr of heat rejection, and the design service water heating load exceeds 1,000,000 Btu/h.

The required heat recovery system shall have the capacity to provide the smaller of:

1. Sixty percent of the peak heat rejection load at design conditions; or
2. The preheating required to raise the peak service hot water draw to 85°F (29°C).

Exceptions:

1. Facilities that employ condenser heat recovery for space heating or reheat purposes with a heat recovery design exceeding 30 percent of the peak water-cooled condenser load at design conditions.
2. Facilities that provide 60 percent of their service water heating from site **solar or site recovered energy** or from other sources.

❖ *The code requires heat recovery from the condenser side of water-cooled systems for preheating service hot water in large 24-hour facilities. Typical applications are homes, dormitories, mixed-use retail residential projects, commercial kitchens and institutions such as prisons and hospitals. Note that a facility must comply with the requirement if all the following are true:*

- *The facility operates 24 hours a day.*
- *The total installed heat rejection capacity of the water-cooled system exceeds 6,000,000 Btu/h (1759 kW). This equates to roughly 400 tons of electrical chiller capacity or 250 to 300 tons of gas-or thermally fired chiller capacity.*
- *The design service water heating load exceeds 1,000,000 Btu/h (293 kW). An example of this would be a 1,000-bed nursing home [at 1.5 gallons per hour per bed].*

*Exception 1 would accept systems that use the recovered heat for space-heating purposes instead of the normally required water heating. Exception 2 simply excludes locations where at least 60 percent of the energy for service water heating comes from either a **solar heating system** that is installed on site or is recovered from some process or equipment within the building.*

C404.7.2 Time switches. Time switches or other control method that can automatically turn off and on heaters and pumps according to a preset schedule shall be installed on all heaters and pumps. Heaters, pumps and motors that have built in times shall be deemed in compliance with this requirement.

Exceptions:

1. Where public health standards require 24-hour pump operation.
2. Where pumps are required to operate solar-and waste-heat-recovery pool heating systems.

- ❖ *Time switches or other control methods provide an easy system for pool operations and energy savings. The application of Exception 1 is dependent on the requirements of the local health department in the jurisdiction. Because the pools are often in public areas, the health department may require continuous filtering or circulation. Exception 2 grants a credit for using other systems that help the pool and the inground permanently installed spa operate more efficiently. Therefore, when solar-and waste-heat recovery systems are used to heat the pool and spa, the exception eliminates the time-switch requirement.*

C404.7.3 Covers. Heated pools and inground permanently installed spas shall be provided with a vapor-retardant cover.

Exception: A vapor-retardant cover is not required for pools deriving over 70 percent of the energy for heating from site-recovered energy, such as a heat pump or solar energy source computed over an operating season.

- ❖ *This section states heated pools and inground permanently installed spas are required to have a vapor-retardant cover. This type of cover is not required to provide any minimum level of insulation value. It simply will help hold some of the heat in, much as placing a lid on a pot will help retain the heat. An exception is a vapor-retardant cover is not required for pools deriving over 70 percent of the energy for heating from site-recovered energy, such as a heat pump or solar energy source computed over an operating season.*

C407.6 Calculation software tools. Calculation procedures used to comply with this section shall be software tools capable of calculating the annual energy consumption of all building elements that differ between the standard reference design and the proposed design and shall include the following capabilities.

1. Computer generation of the standard reference design using only the input for the proposed design. The calculation procedure shall not allow the user to directly modify the building component characteristics of the standard reference design.
2. Building operation for a full calendar year (8,760 hours).
3. Climate data for a full calendar year (8,760 hours) and shall reflect approved coincident hourly data for temperature, solar radiation, humidity and wind speed for the building location.
4. Ten or more thermal zones
5. Thermal mass effects.
6. Hourly variations in occupancy, illumination, receptacle loads, thermostat settings, mechanical ventilation, HVAC equipment availability, service hot water usage and any process loads.
7. Part-load performance curves for mechanical equipment.
8. Capacity and efficiency correction curves for mechanical heating and cooling equipment.
9. Printed code official inspection checklist listing each of the proposed design component characteristics from Table C407.5.1(1) determined by the analysis to provide compliance, along with their respective performance ratings (e.g., R-value, U-factor, SHGC, HSPF, AFUE, SEER, EF, etc.).

- ❖ *Software tools such as DOE-2, BLAST, COMcheck or Energy/Plus capable of calculating the annual energy consumption of all building elements can be used to differentiate between the standard reference design and the proposed design. The calculation software tool shall have the ability to model all of the following:*
 - *Building operation and climate data for 8760 hours per year.*
 - *10 more thermal zones.*
 - *Thermal mass effects.*
 - *Part-load performance curves for mechanical heating and cooling equipment.*
 - *Capacity and efficiency correction curves for mechanical heating and cooling equipment.*
 - *Printed code official inspection checklist listing each of the proposed design components characteristics.*

R403.9.2 Time switches Time switches or other control method that can automatically turn off and on heaters and pumps according to a preset schedule shall be installed on all heaters and pumps. Heaters, pumps and motors that have built in timers shall be deemed in compliance with this requirement.

Exceptions:

1. Where public health standards require 24-hour pump operation.
 2. Where pumps are required to operate **solar-and waste-heat-recovery pool heating systems**.
- ❖ *The use of a time switch or other control method to control the heater and pumps provides an easy system for pool and spa operations and energy savings. The application of Exception 1 is dependent on the requirements of the local health department in the jurisdiction. Because these are often public pools and spas, the health department may require continuous filtering or circulation. Exception 2 grants a credit for using other systems that help the pool and spa operate more efficiently. Therefore, when **solar-and waste-heat recovery systems** are used to heat the pool, the exception eliminates the time switch requirement.*

R403.9.3 Covers. Heated pools and inground permanently installed spas shall be provided with a vapor-retardant cover.

Exception: Pools deriving over 70 percent of the energy for heating from site-recovered energy, such as a heat pump or **solar energy source** computed over an operating season.

- ❖ *When energy is used to heat a pool or a spa, a cover is required to help hold in the heat and keep it from being lost to the surrounding air. The level of protection or insulation that the cover must provide depends upon the temperature that the pool is heated to. Any time a pool or spa is heated, the code will require a vapor-retardant pool cover. This type of cover is not required to provide any minimum level of insulation value. It simply will help hold some of the heat in, much as placing a lid on a pot will help retain the heat. In situations where the pool is heated above 90°F (32°C), the cover must be insulated to the specified R-12 level. The exception is similar to that found in Section R403.9.2.*

3. 2012 International Fire Code (IFC):

105.7.13 Solar photovoltaic power systems. A construction permit is required to install or modify solar photovoltaic power systems.

- ❖ *Section 605.11 regulates solar photovoltaic power system installations on buildings. Because of the unique electrical and physical hazards they present to fire fighters and the impact such systems have on fire suppression operations, a permit is required.*

317.3 Rooftop structure and equipment clearance. For all vegetated roofing systems abutting combustible vertical surfaces, a Class A-rated roof system complying with ASTM E108 or UL 790 shall be achieved for a minimum 6-foot-wide (1.8 m) continuous border placed around rooftop structures and all rooftop equipment including, but not limited to, mechanical and machine rooms, penthouses, skylights, roof vents, solar panels, antenna supports, and building service equipment.

- ❖ *Where a building utilizes combustible construction for the construction of penthouses, mechanical equipment or rooftop elevator machine rooms, this section requires a minimum 6-foot-wide (1.8 m) border constructed around the combustible construction. The buffer space is also constructed to the IBC requirements for a Class A roof assembly (see the commentary to Section 317.1). The buffer space is not required if the roof garden or landscaped roof is separated by more than 6 feet (1.8 m) from the combustible construction or when noncombustible construction is used. This buffer space will slow fire spread between landscaped areas and combustible construction and will afford fire fighter access.*

601.2 Permits. Permits shall be obtained for refrigeration systems, battery systems and solar photovoltaic power systems as set forth in Sections 105.6 and 105.7.

- ❖ *Only three systems discussed in Chapter 6 require permits: the operation of refrigeration systems, the installation of storage battery systems and the installation of solar photovoltaic power systems. The permit for operation of refrigeration systems is intended to warn emergency responders that a potential hazard exists. This information will better equip them to respond to such a call. The permit for installation of a storage battery system or the installation of a solar photovoltaic power system ensures the proper safety requirements and features are installed (see commentary, Section 105).*

605.11 Solar photovoltaic power systems. Solar photovoltaic power systems shall be installed in accordance with Sections 605.11.1 through 605.11.4, the International Building Code and NFPA 70.

Exception: Detached, nonhabitable Group U structures including, but not limited to, parking shade structures, carports, solar trellises and similar structures shall not be subject to the requirements of this section.

- ❖ *The ever-increasing demand for alternative power sources brings with it new hazards to confront emergency responders. Among the most popular of these alternative energy sources are solar photovoltaic (PV) power systems. A number of United States electric utility power suppliers offer incentives for the installation of PV systems on buildings because such systems offer the property owners the ability to generate their own electricity and, in many cases, sell excess electricity back to the utility provider. Such an arrangement is a benefit to the utility provider because it reduces their power generation demand, which in turn can control the rates that commercial and residential customers pay. Demand in the past decade for PV power systems has increased by several orders of magnitude. According to the U.S. Energy Information Administration, approximately 21,200 PV cells and modules were shipped domestically in 1999; by 2008, the number shipped was over 524,200. As the number of PV power systems increases, economy of scale will continue to reduce the systems, costs, making them more common on commercial and residential buildings (see Figure 605.11).*

PV systems are designed to convert light energy into direct current (DC) electricity. They have no moving parts and do not contain fluids. The light-to-electricity conversion begins at the PV cell, which is commonly a semiconductor device that generates electricity when exposed to light. To be effective, PV cells are assembled into PV modules, which are then assembled into PV panels. The panels are assembled onto a frame or a flexible substrate, which then can be affixed to the roof of buildings to create a PV array. The PV arrays and its modules are wired together and generally operate as a series electrical circuit. PV arrays are required by NFPA 70 to have a fuse or other means of branch-circuit protection to prevent them from being overloaded. While not required, a PV array is commonly equipped with a blocking diode. A blocking diode is analogous to a check valve in a piping system because it limits the direction the electrons can travel. The blocking diode prevents electrical current from one power supply from finding entry into another. In PV systems, the blocking diode protects each individual PV panel if other panels fail and prevents the withdrawal of electricity from the system during the nighttime (see Figure 605.11).

The greatest danger facing emergency responders operating in proximity to solar energy collection systems is the lack of knowledge needed to operate safely around these systems. Some of the potential hazards associated with PV systems are tripping hazards and/or falls for fire fighters operating on the roof and the potential for earlier roof collapse due to the added dead load and electric shock. The provisions of Sections 605.11 through 605.11.4 were developed to provide for the proper installation of PV systems and to address the potential hazards to fire fighters by requiring:

- *Compliance with the provisions of Sections 1511 and 3111 of the IBC and Section 690 of NFPA 70;*
- *Identification of PV circuits and disconnects;*
- *Location of conductors to reduce or prevent potential trip hazards; and*
- *Creation of pathways where fire fighters can perform manual ventilation operations on roofs.*

The exception to this section recognizes that the installation of PV systems on detached Group U occupancy structures that are not designed for habitation or occupation is unlikely.

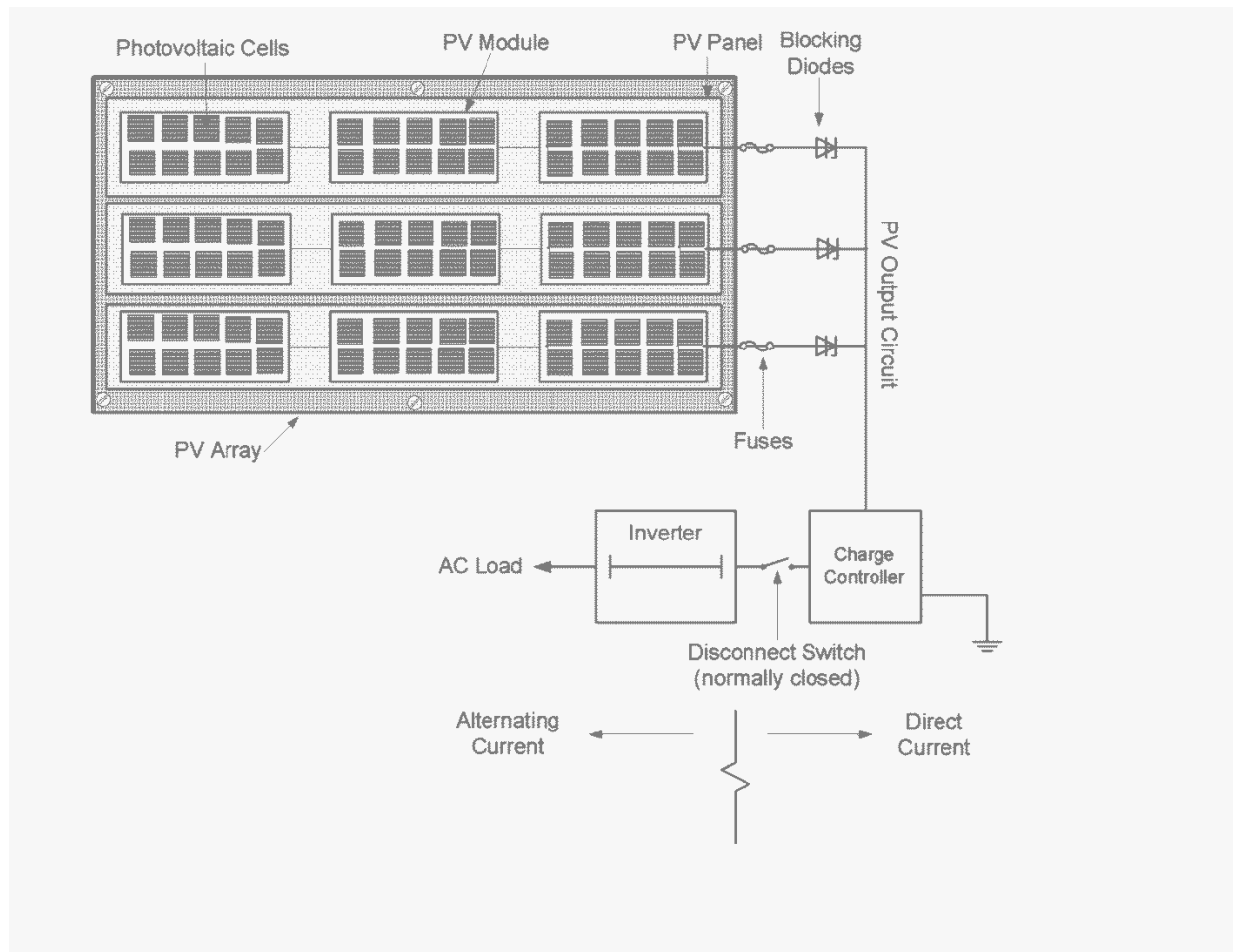

COMMENTARY FIGURE 605.11

605.11.1 Marking. Marking is required on interior and exterior Direct Current (DC) conduit, enclosures, raceways, cable assemblies, junction boxes, combiner boxes, and disconnects.

- ❖ This section introduces the marking requirements for **PV systems** including color and labeling with the name of the system components. **PV systems** must be marked in order to provide emergency responders with appropriate visual warning and guidance with respect to working around and isolating the **PV system**. This can facilitate identifying energized electrical lines that connect the **solar modules** to the inverter, as these should not be cut when venting for smoke removal.

605.11.1.1 Materials. The materials used for marking shall be reflective, weather resistant and suitable for the environment. Marking as required in sections 605.11.1.2 through 605.11.1.4 shall have all letters capitalized with a minimum height of 3/8 inch (9.5 mm) white on red background.

- ❖ *Markings need to be durable, reflective and weather resistant to ensure that they will be visible and legible when needed. While there are no specific material standards included in this section, Underwriters Laboratories marking and labeling system standard, UL 969, could be used in evaluating weather resistance. Note that listing of markings is not required. The markings should be readily visible from any direction of approach.*

605.11.1.2 Marking content. The marking shall contain the words “WARNING: PHOTOVOLTAIC POWER SOURCE”.

- ❖ *The warning provided by the marking must be clear and concise to have the desired effect of capturing personnel attention and conveying the message.*

605.11.1.3 Main service disconnect. The marking shall be placed adjacent to the main service disconnect in a location clearly visible from the location where the disconnect is operated.

- ❖ *As part of the PV system identification requirements, this section requires that the main service disconnect for the PV system be clearly identified. NEC Section 690.17 requires the disconnect means to be located in a readily accessible location and be of a design that does not expose the operator to energized components. Emergency responders should understand that operating this disconnect switch only stops the flow of electricity on the AC portion of the system – it does not stop the PV arrays from generating power. They will continue to generate DC electricity during daylight hours.*



COMMENTARY FIGURE 605.11.1.3

605.11.1.4 Location of Marking. Marking shall be placed on interior and exterior DC conduit, raceways, enclosures and cable assemblies every 10 feet (3048 mm), within 1 foot (305 mm) of turns or bends and within 1 foot (305 mm) above and below penetrations of roof/ceiling assemblies, walls or barriers.

- ❖ *Component identification marking is required on all interior and exterior PV system wiring components and junction boxes to alert the fire service to avoid contacting or cutting them. Because of the personnel hazards posed by these systems, marking must be placed on components every 10 feet, at turns and above and or below penetrations and all DC combiner and junction boxes.*

605.11.2 Locations of DC conductors. Conduit, wiring systems, and raceways for photovoltaic circuits shall be located as close as possible to the ridge or hip or valley and from the hip or valley as directly as possible to an outside wall to reduce trip hazards and maximize ventilation opportunities. Conduit runs between sub arrays and to DC combiner boxes shall be installed in a manner that minimizes the total amount of conduit on the roof by taking the shortest path from the array to the DC combiner box. The DC combiner boxes shall be located such that conduit runs are minimized in the pathways between arrays. DC wiring shall be installed in metallic

conduit or raceways when located within enclosed spaces in a building. Conduit shall run along the bottom of load bearing members.

- ❖ *This section specifies the layout and locations for **PV system components** to keep clear the required pathways around and between PV arrays and their hardware for fire fighter access and ventilation operations. While Section 690 IV of the NEC allows any wiring material and method in that code to be utilized in **PV system installations**, this section is more restrictive by requiring that **PV system** DC wiring in concealed building spaces be installed in metallic conduit or other approved raceways, thus providing increased physical protection.*

605.11.3 Access and pathways. Roof access, pathways, and spacing requirements shall be provided in accordance with Sections 605.11.3.1 through 605.11.3.3.3.

Exceptions:

1. Residential structures shall be designed so that each **photovoltaic array** is no greater than 150 feet (45 720 mm) by 150 feet (45 720 mm) in either axis.
 2. **Panels/modules** shall be permitted to be located up to the roof ridge where an alternative ventilation method approved by the fire chief has been provided or where the fire chief has determined vertical ventilation techniques will not be employed.
- ❖ *This section introduces a major element of the **PV system** design which is the requirement to provide access and paths so firefighters can perform the important task of manual ventilation by cutting one or more holes in a building roof. The provisions in Sections 605.11.3.1 through 605.11.3.3.3 address the placement of **PV arrays** on building roofs. It should be noted that these requirements do not apply to buildings regulated by the International Residential Code for One- and Two-Family Dwellings (IRC). See the commentary to Section 102.5 for a discussion of the relationship between the code and the IRC. Exception 1 to this section limits the maximum area of **PV arrays** on Group R structures to a maximum area of 22,500 ft.² with a maximum dimension of 150 feet.*

*Exception 2 exempts **PV arrays** from the spacing requirements when the fire chief has approved an alternative ventilation method or indicates that vertical manual ventilation practices will not be employed. Conditions that could be considered under this exception include, but are not limited to proximity and type of adjacent exposures, alternative access opportunities (as from adjoining roofs), adequate ventilation opportunities beneath **solar arrays** that are significantly elevated or widely-spaced, or by module set back from other rooftop equipment, installation of automatic ventilation devices or new technology, methods, or other innovations that ensure adequate fire department access, pathways and ventilation opportunities. Note that this exception does not exempt the PV system installation from the other requirements in Section 605.11, including the requirement for obtaining a construction permit in accordance with Section 105.7.14.*

605.11.3.1 Roof access points. Roof access points shall be located in areas that do not require the placement of ground ladders over openings such as windows or doors, and located

at strong points of building construction in locations where the access point does not conflict with overhead obstructions such as tree limbs, wires, or signs.

- ❖ *Roof access points must be defined as areas where ladder placement will not be over openings so as to obstruct ingress or egress of personnel, interfere with the use of openings for ventilation or expose the ground ladder to heat, smoke or fire erupting from the opening. Ladder placement must also be located at strong points of building construction and in locations where they will not conflict with overhead obstructions.*

605.11.3.2 Residential systems for one- and two-family dwellings. Access to residential systems for one- and two-family dwellings shall be provided in accordance with Sections 605.11.3.2.1 through 605.11.3.2.4.

- ❖ *This section introduces the **PV system access requirements** for residential buildings. See figure 605.11.3.2.*



COMMENTARY FIGURE 605.11.3.2

605.11.3.2.1 Residential buildings with hip roof layouts. **Panels/modules** installed on residential buildings with hip roof layouts shall be located in a manner that provides a 3 foot (914 mm) wide clear access pathway from the eave to the ridge on each roof slope where

panels/modules are located. The access pathway shall be located at a structurally strong location on the building capable of supporting the live load of fire fighters accessing the roof.

Exception: These requirements shall not apply to roofs with slopes of two units vertical in twelve units horizontal (2:12) or less.

- ❖ *PV arrays installed on the roofs of Group R-3 one- and two-family dwellings must be located so they create a minimum 3 foot clearance between the PV array and roof ridge so firefighters have a unobstructed area in which to cut ventilation openings. The exception exempts low-slope roofs i.e., a slope that is 2:12 or less due to the reduced hazards of such flatter roofs.*

605.11.3.2.2 Residential buildings with a single ridge. Panels/modules installed on residential buildings with a single ridge shall be located in a manner that provides two 3 foot (914 mm) wide access pathways from the eave to the ridge on each roof slope where panels/modules are located.

Exception: This requirement shall not apply to roofs with slopes of two units vertical in twelve units horizontal (2:12) or less.

- ❖ *PV arrays installed on the roofs of Group R-3 one- and two-family dwellings must be located so they create a minimum 3 foot clearance between the PV array and roof ridge so firefighters have a unobstructed area in which to cut ventilation openings. The exception exempts low-slope roofs i.e., a slope that is 2:12 or less due to the reduced hazards of such flatter roofs.*

605.11.3.2.3 Residential buildings with roof hips and valleys: Panels/modules installed on residential buildings with roof hips and valleys shall be located no closer than 18 inches (457 mm) to a hip or a valley where panels/modules are to be placed on both sides of a hip or valley. Where panels are to be located on only one side of a hip or valley that is of equal length the panels shall be permitted to be placed directly adjacent to the hip or valley.

Exception: These requirements shall not apply to roofs with slopes of two units vertical in twelve units horizontal (2:12) or less.

- ❖ *Where installed on both sides of a roof hip or valley, PV arrays installed on the roofs of Group R-3 one- and two-family dwellings must be located so they create a minimum 3 foot clearance between the PV array and the bottom of the roof hip or valley so firefighters have a unobstructed area in which to cut ventilation openings. The exception exempts low-slope roofs i.e., a slope that is 2:12 or less due to the reduced hazards of such flatter roofs.*

605.11.3.2.4 Residential building smoke ventilation. Panels/modules installed on residential buildings shall be located no higher than 3 feet (914 mm) below the ridge in order to allow for fire department smoke ventilation operations.

- ❖ *Manual ventilation is most effective when accomplished at the highest portion of the roof above the fire. This section establishes an obstruction free zone within 3 feet of the roof*

ridge in order to optimize the area available for effective ventilation, allowing for a two foot trench cut.

605.11.3.3 Other occupancies. Access to systems for occupancies other than one- and two-family dwellings shall be provided in accordance with Sections 605.11.3.3.1 through 605.11.3.3.3.

Exception: Where it is determined by the *fire code official* that the roof configuration is similar to that of a one- or two-family dwelling, the residential access and ventilation requirements in Sections 605.11.3.2.1 through 605.11.3.2.4 shall be permitted to be used.

- ❖ *This section introduces the **PV system access** for non-single family residential buildings. The exception recognizes that non-residential buildings are often constructed in a residential configuration (such as in the case of townhouses, condominiums, or single family attached buildings) and authorizes the fire code official to allow the provisions for residential building construction styles to be used. The access and ventilation requirements are not occupancy-specific but are affected most by the construction configuration.*

605.11.3.3.1 Access. There shall be a minimum 6 foot (1829 mm) wide clear perimeter around the edges of the roof.

Exception: Where either axis of the building is 250 feet (76 200 mm) or less, there shall be a minimum 4 foot (1290 mm) wide clear perimeter around the edges of the roof.

- ❖ ***PV arrays** installed on the roofs of non-residential buildings must be located so they create a minimum 6 foot clearance between the PV array and roof edge so firefighters have an unobstructed area in which to operate when cutting ventilation openings.*

605.11.3.3.2 Pathways. The **solar installations** shall be designed to provide designated pathways. The pathways shall meet the following requirements:

1. The pathway shall be over areas capable of supporting the live load of fire fighters accessing the roof.
2. The centerline axis pathways shall be provided in both axes of the roof. Centerline axis pathways shall run where the roof structure is capable of supporting the live load of fire fighters accessing the roof.
3. Shall be a straight line not less than 4 feet (1290 mm) clear to skylights or ventilation hatches.
4. Shall be a straight line not less than 4 feet (1290 mm) clear to roof standpipes.
5. Shall provide not less than 4 feet (1290 mm) clear around roof access hatch with at least one not less than 4 feet (1290 mm) clear pathway to parapet or roof edge.

- ❖ *Pathways must be established in the design of the **solar installation** and meet the requirements listed in this section. Placing the pathways over or adjacent to structural elements of the building provides a stable walking platform for personnel who will likely be carrying additional heavy equipment up to the roof. The pathways being straight and with a 4-foot (1290 mm) clearance to tripping and other hazards helps provide a safe working environment for personnel assigned to rooftop operations.*

605.11.3.3.3 Smoke ventilation. The **solar installation** shall be designed to meet the following requirements:

1. Arrays shall be no greater than 150 feet (45 720 mm) by 150 feet (45 720 mm) in distance in either axis in order to create opportunities for fire department smoke ventilation operations.
2. Smoke ventilation options between array sections shall be one of the following:
 - 2.1. A pathway 8 feet (2438 mm) or greater in width.
 - 2.2. A 4-foot (1290 mm) or greater in width pathway and bordering roof skylights or smoke and heat vents.
 - 2.3. A 4-foot (1290 mm) or greater in width pathway and bordering 4-foot by 8-foot (1290 mm by 2438 mm) “venting cutouts” every 20 feet (6096 mm) on alternating sides of the pathway.

- ❖ *This section establishes design options for providing adequate space among and around the **PV arrays** for safe fire department ventilation operations.*

Appendix J

J101.7 Tactical considerations. The center circle shall include the name of the local fire service and when required the letters TC for tactical considerations. When fire fighters conduct preplan operations, a unique situation(s) for tactical considerations shall be identified and the information provided to the fire dispatch communications center to further assist fire fighters in identifying that there is special consideration(s) for this occupancy. Special consideration designations include, but are not limited to:

1. Impact-resistant drywall.
2. Impact-resistant glazing, such as blast or hurricane-type glass.
3. All types of roof and floor structural members including but not limited to post-tension concrete, bar joists, solid wood joists, rafters, trusses, cold-formed galvanized steel, I-joists and I-beams; green roof with vegetation, soil and plants.
4. Hazardous materials (explosives, chemicals, plastics, etc.).
5. **Solar panels** and DC electrical energy.
6. HVAC system; and smoke management system for pressurization and exhaust methods.
7. Other unique characteristic(s) within the building that are ranked according to a potential risk to occupants and fire fighters.

- ❖ *Section J101.7 requires the sign to convey relevant tactical information that can be used by fire fighters prior to commencing an interior fire attack. This could include the use of terrorism-resistant building materials; impact-resistant glazing or construction; the storage or use of hazardous materials; certain types of structural components that may have a propensity for rapid failure under fire exposure or any other potential hazards that could impact the health and safety of emergency responders.*

4. 2012 International Green Construction Code (IgCC):

Section 202 Definitions

Solar photovoltaic system. Devices such as photovoltaic (PV) modules and inverters that are used to transform solar radiation into energy.

Solar thermal equipment. A device that uses solar radiation to heat water or air for use within the facility for service water heating, process heat, space heating or space cooling.

603.3.7.1 Solar electric. Equipment and systems providing electric power through conversion of solar energy directly to electric power shall be capable of being metered so that the peak electric power (kW) provided to the building and its systems or to off-site entities can be determined at 15-minute intervals and the amount of electric power (kWh) provided to the building and its systems can be determined at intervals of 1 hour or less.

- ❖ *The intent of this section is to monitor the actual output of on-site solar electric systems. The code requires on-site renewable energy systems to meet a specific percentage of the building's annual energy needs, and the metering will ensure that the requirements are met on an annual basis. The data can also be used by building owners to track daily, weekly and monthly performance of these systems.*

603.3.7.2 Solar thermal. Equipment and systems providing heat to fluids or gases through the capture of solar energy shall be capable of being metered so that the peak thermal energy (Btu/h) provided to the building and its systems or to off-site entities can be determined at 15-minute intervals and the amount of heat captured (Btu) for delivery to the building and its systems can be determined intervals of 1 hour or less.

Exception: Systems with a rated output of less than 100 kBtu/hr shall not be required to have the capacity to be metered.

- ❖ *The code requires on-site renewable energy systems to meet a specific percentage of the building's annual energy needs, and the metering will ensure that the requirements are met on an annual basis. The data can also be used by building owners to track daily, weekly, and monthly performance of these systems. The measurement chart for the meter is in 15 minute increments to record the amount of heat captured for delivery to the building and its systems can be determined intervals of one hour or less. Systems with a rated output of less than 100 kBtu/hr are exempt from measurement because the energy used is minimal and difficult to read on a meter chart.*

610.1 Renewable energy systems requirements. Buildings that consume energy shall comply with this section. Each building or surrounding lot or building site where there are multiple buildings on the building site shall be equipped with one or more renewable energy systems in accordance with this section.

Renewable energy systems shall comply with the requirements of Section 610.2 for what solar photovoltaic systems, Section 610.3 for wind systems, or Section 610.4 for solar water heating systems, and Section 610.5 for performance monitoring and metering of these systems as approved by the code official. These systems shall be commissioned in accordance with the requirements of Section 611.

Exception: Renewable energy systems are not required for the following:

1. Buildings or building sites where there are multiple buildings on the building site providing not less than 2 percent of the total estimated annual energy use of the building, or collective buildings on the site, with onsite **renewable energy** generation systems complying with the requirements of Sections 610.2, 610.3 or 610.4.
2. Where not less than 4 percent of the total annual building energy consumption from renewable generation takes the form of a 10-year commitment to **renewable energy** credit ownership, confirmed by the code official.
3. Where the combined application of onsite generated **renewable energy** and a commitment to renewable energy credit ownership as confirmed by the code official, totals not less than 4 percent of the total annual building energy consumption from **renewable** generation.

❖ *This section of the code requires the use of one or any combination of three **renewable energy** systems to provide a portion of the energy consumed in all buildings. This section directs the user to subsequent sections that describe the specific requirements of the three different renewable energy systems: **solar photovoltaic**, wind, and **solar water heating**. Additionally, this section requires that the **renewable energy** system selected meet the commissioning, performance monitoring and metering section of this code.*

*Although notes as “exceptions”, there are three alternatives for meeting the performance based or prescriptive levels of **renewable energy** system requirements of this code as follows:*

*Exception/Alternative 1 allows existing **renewable energy** systems on the site or existing buildings on the site to meet the requirements of this section provided that they collectively have the capacity to generate at least 2% of the estimated annual energy consumed from renewable energy sources for all the buildings on the site including new construction covered by this code.*

*Exception/Alternative 2 allows the use of a 10 year commitment to purchase **Renewable Energy Credits (RECs)**, also known as **Renewable Energy Certificates** or **Green Power** to offset the requirement for on-site **renewable energy** systems. In this case, a larger percentage (4%) of annual energy consumption is required to be offset because of transmission losses incurred for off-site renewable energy sources as well as the longevity, typically 20 years or more, of installed on-site **renewable energy** systems. In locations where a 10 year contract for RECs is unavailable there should be at least a 1 year contract and commitment from the building owner to renew the contract for a time period of at least 10 years.*

*Exception 3/Alternative 3 allows the combined use of purchased RECs and **renewable energy** systems to offset not less than 4% of the estimated annual energy consumptions of the building(s) on the site.*

610.1.1 Building performance-based compliance. Buildings and surrounding property or building sites where there are multiple buildings on the building site, that are designed and constructed in accordance with Section 601.3.1, performance-based compliance, shall be equipped with one or more **renewable energy** systems that have the capacity to provide not less

than 2 percent of the total calculated annual energy use of the building, or collective buildings on the site.

- ❖ *This section addresses buildings that are designed using the performance compliance path of Section 601.3.1. It requires that at least 2% of the total estimated annual energy consumed by the building(s) as determined by the designer is provided by one or more on-site renewable energy systems.*

610.1.2 Building prescriptive compliance. Buildings and surrounding property or building sites where there are multiple buildings on the building site, that are designed and constructed in accordance with Section 601.3.2 prescriptive compliance, shall be equipped with one or more renewable energy systems that have the capacity to provide not less than 2 percent of the total estimated annual energy use of the building, or collective buildings on the building site, with onsite renewable energy by calculation demonstrating that onsite renewable energy production has a rating of not less than 1.75 Btu/h (0.5 W) or not less than 0.50 watts per square foot of conditioned floor area, and using any single or combination of renewable energy generation systems meeting the requirements of Sections 610.2, 610.3, or 610.4.

- ❖ *This section addresses buildings that are designed using the prescriptive compliance path of Section 601.3.2 of the code. There are two prescriptive compliance options. Option 1 requires that at least 2% of the total estimated annual energy consumed by the building(s) on site be provided by one or more on-site renewable energy systems. Option 2 requires that one of more on-site renewable energy systems are selected that have a rated capacity of at least 1.75 Btu/hr or 0.50 watts per square foot of conditioned floor area.*

610.2 Solar photovoltaic systems. Solar photovoltaic systems shall be sized to provide not less than 2 percent of the total estimated annual electric energy consumption of the building, or collective buildings on the building site in accordance with Section 610.1.1 or 610.1.2.

- ❖ *The intent of this section is that solar photovoltaic systems can be used to comply with Sections 610.1.1 or 610.1.2.*

610.2.1 Limitation. Solar photovoltaic systems shall not be used to comply with Section 610.1 where building sites have a total global insolation levels lower than 2.00 kWh/m²/day as determined in accordance with NREL, SERI TR 642-761.

- ❖ *This section of the code prohibits solar photovoltaic systems from achieving compliance with Section 610.1 where building sites with total global insolation levels are lower than 2.00 kWh/m²/day as determined by NREL SERI TR-642-761 because it may not be cost beneficial. NREL SERI TR-642-761 is a summary of five simple broadband models for clear sky global insolation levels that have been formulated from meteorological conditions based on the solar radiation energy received on a given surface area and recorded during a given period of time.*

610.2.2 Requirements. The installation, inspection, maintenance, repair and replacement of solar photovoltaic systems and system components shall comply with the manufacturer's

instructions, Section 610.2.2.1, the International Fire Code, the International Building Code and NFPA 70.

- ❖ *The IFC includes comprehensive requirements for firefighter access and safety criteria for roofs equipped with solar photovoltaic systems. A photovoltaic system should not be mounted on a wood structure nor be of combustible materials. The IBC contains guidance on how to deal with rooftop loads imposed by solar photovoltaic systems. Section 610.2.2 provides safety for building occupants and emergency responders by requiring compliance with the comprehensive code requirements of the IFC, the IBC, and NFPA 70. Taken together, these codes regulate the electrical, fire, wind and structural aspects of these systems. Additionally, proof of their estimated performance of the installed PV solar system must be provided to the building owner.*

610.2.2.1 Performance verification. Solar photovoltaic systems shall be tested on installation to verify that the installed performance meets the design specifications. A report of the tested performance shall be provided to the building owner.

- ❖ *The installation of solar photovoltaic systems is regulated by the IBC, the IFC and NFPA 70. The performance level generated for sustainability credit is appropriate for the code.*

610.4 Solar water heating equipment. Not less than 10 percent of the building's annual estimated hot water energy usage shall be supplied by onsite solar water heating equipment.

- ❖ *This section of the code addresses the use of solar water heating systems in meeting the general on-site renewable energy requirements of Section 610. If this renewable energy choice is selected, not less than 10% of the buildings annual estimated hot water energy usage must be provided in order to gain compliance.*

610.5 Renewable energy system performance monitoring and metering. Renewable energy systems shall be metered and monitored in accordance with Sections 610.5.1 and 610.5.2.

- ❖ *Renewable energy systems must be metered and monitored in accordance with Sections 610.5.1 and 610.5.2.*

610.5.1 Metering. Renewable energy systems shall be metered separately from the building's electrical and fossil fuel meters. Renewable energy systems shall be metered to measure the amount of renewable electric or thermal energy generated on the building site in accordance with Section 603.

- ❖ *Renewable energy systems must be metered separately from the building's electrical and fossil fuel meters to account for renewable electric or thermal energy generated on the building site in accordance with Section 603 of the code.*

610.5.2 Monitoring. Renewable energy systems shall be monitored to measure the peak electric or thermal energy generated by the renewable energy systems during the building's anticipated peak electric or fossil fuel consumption period in accordance with Section 603.

- ❖ *By requiring separate metering and monitoring, this section provides assurance to the building owner that the installed **renewable energy** system is providing the required performance as estimated by the designer and as required by the code.*

5. 2012 **International Mechanical Code (IMC):**

Chapter 14

Solar Systems

Note: *Although the IMC Commentary Solar Systems chapter contained a number of valuable figures, we were unable to insert them in this document.*

General Comments

- ❖ *Chapter 14 contains requirements for the construction, alteration and repair of all systems and components of solar energy systems used for space heating or cooling, domestic hot water heating or processing. The provisions of this chapter are limited to those necessary to achieve safe installations that are relatively hazard free.*

A solar energy system can be designed to handle 100 percent of the energy load of a building, although this is rarely accomplished. Because solar energy is a lowintensity energy source and not always available because of the weather, it is usually necessary to supplement a solar energy system with other traditional energy sources.

Solar heating and cooling systems are classified as either passive or active systems. A passive solar energy system uses solar collectors, a gas or liquid heat-transfer medium and distribution piping or ductwork. This system does not use circulators or fans but relies on natural (gravity) flow. The flow of energy (heat) is by natural convection, conduction and radiation. Commentary Figures 14(1) and 14(2) show typical passive solar heating applications.

A complete active solar energy system includes solar collectors, a gas or liquid heat transfer medium, piping, ducts, circulators, fans and controls to move the medium to the load or to an energy storage system. Commentary Figure 14(3) shows a typical active solar system used for space and domestic water heating supplemented by an auxiliary furnace and water heater.

Many design variations exist, such as hybrid systems, with components of both active and passive systems. Solar systems can either be very complex or as simple as glazing, and can act in harmony with the architectural features of the building [see Commentary Figure 14(4)].

Solar designs can be used to improve the performance of conventional space heating systems and work in conjunction with other such systems. For example, a simple passive collection system can greatly improve the performance of an air-to-air or water-to-air heat pump system.

The energy collected by a solar system can be used as it is collected or transferred to some form of thermal storage system. Typical thermal storage systems consist of large quantities of a dense mass, including stone, masonry or water. Storage mass can also consist of materials in which a phase change occurs, such as chemical compounds that store the latent heat required to liquefy the compounds that are solid at room temperature.

If the energy collected by a solar system is not used or stored for later use, the collection system must either stop collecting or dump the energy to the building exterior unless the collection system is designed to withstand the higher temperatures and pressures resulting from the static (no-flow) mode of operation.

Another aspect of solar system installations that must be considered is the structural loading effect that the collectors and supports have on the building's roof system. Collectors can add considerable weight, affect snow accumulation and increase wind loads and uplift forces. As with any roof-mounted equipment or appliances, the installation must also comply with the applicable provisions of the International Building Code® (IBC®).

Purpose

This chapter establishes provisions for the safe installation, operation and repair of solar energy systems. Although such systems use components similar to those of conventional mechanical equipment, many of these provisions are unique to solar energy systems.

CONFIDENTIAL

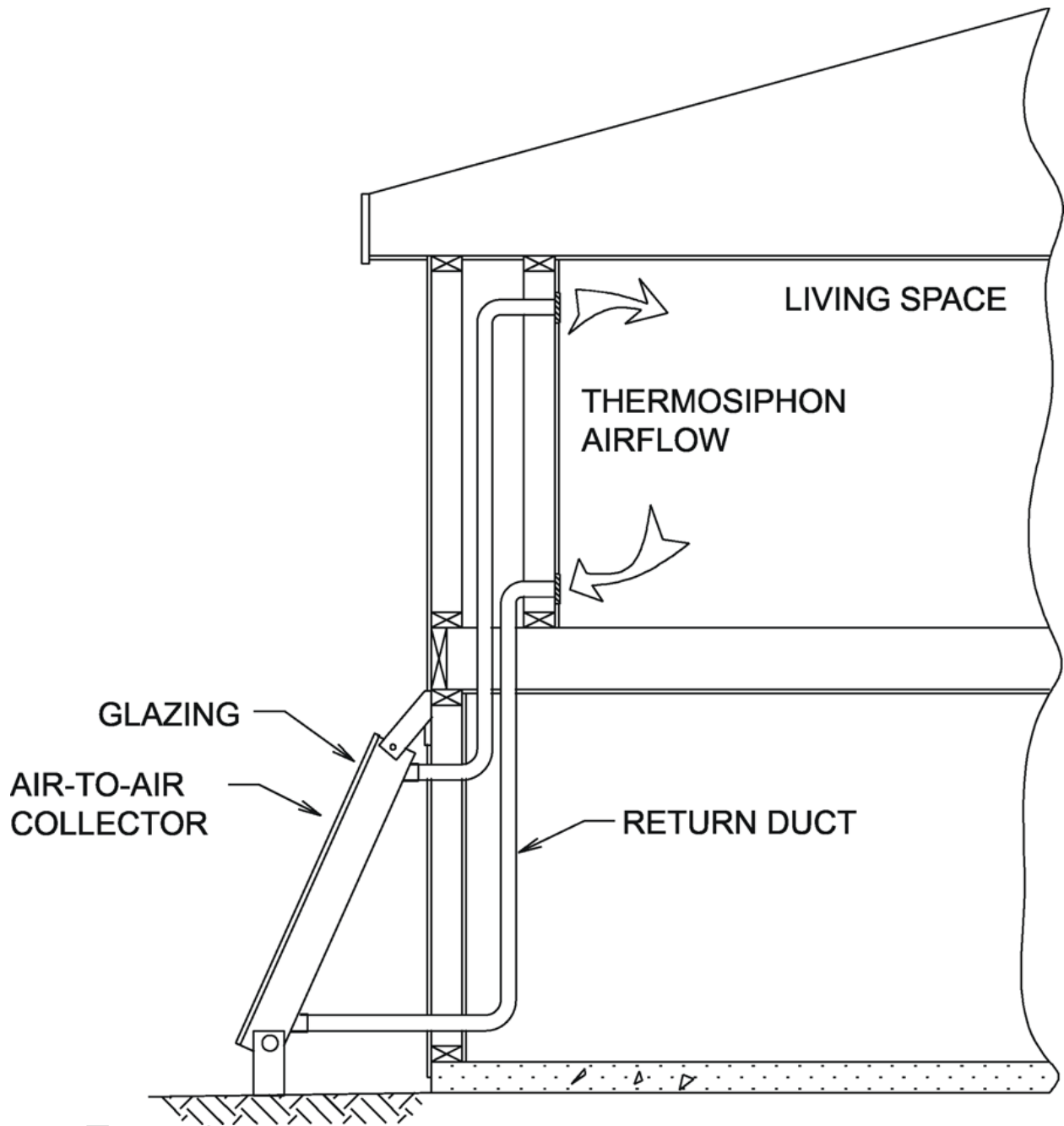

Figure 14(1)
PASSIVE SOLAR SPACE HEATING

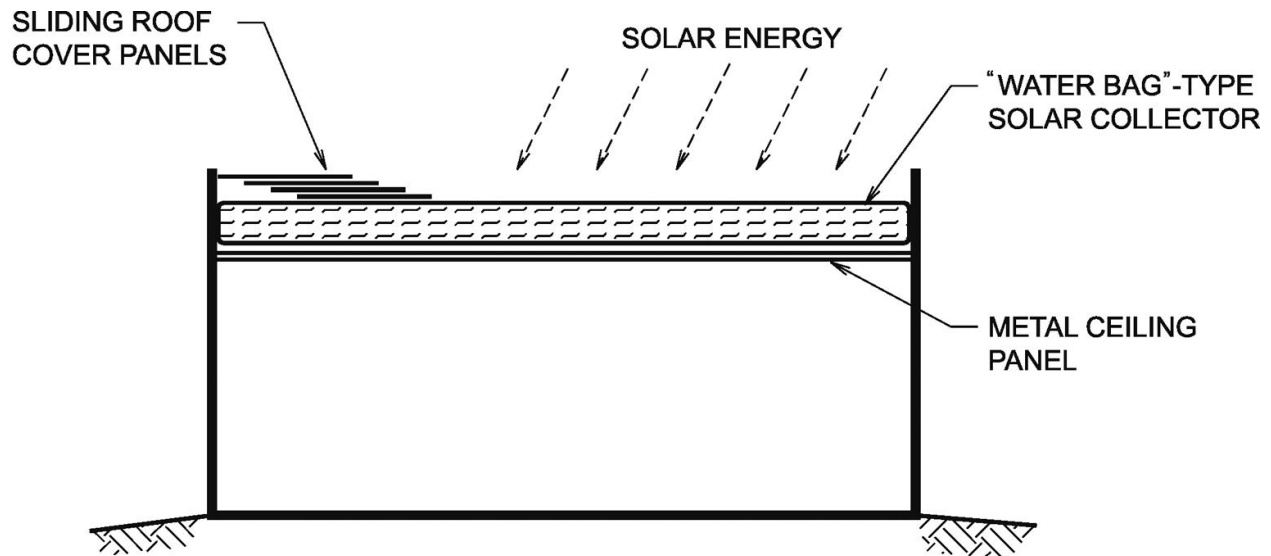

Figure 14(2)
PASSIVE SOLAR HEATING AND COOLING APPLICATION

SECTION 1401 **GENERAL**

1401.1 Scope. This chapter shall govern the design, construction, installation, *alteration* and repair of systems, *equipment* and appliances intended to utilize solar energy for space heating or cooling, domestic hot water heating, swimming pool heating or process heating.

- ❖ *Solar energy can be used for a variety of purposes, including space heating, space cooling, domestic water heating, swimming pool heating and processing. Therefore, the scope encompasses all of these potential solar energy applications, and includes the design, construction, installation, alteration and repair of all systems and equipment.*

1401.2 Potable water supply. Potable water supplies to solar systems shall be protected against contamination in accordance with the *International Plumbing Code*.

Exception: Where all solar system piping is a part of the potable water distribution system, in accordance with the requirements of the *International Plumbing Code*, and all components of the piping system are *listed* for potable water use, cross-connection protection measures shall not be required.

- ❖ *Solar systems may contain conditioning chemicals, antifreeze or heat transfer fluids other than water. The fill and makeup water supply to solar hydronic systems is generally taken directly from the potable water supply of the building. Water supply connections are provided to manually or automatically replace water that is lost from relief/safety valve discharge, evaporation, draindown, control flushing, air purging or leakage. This arrangement causes the potable water supply to be highly susceptible to contamination by backflow. Where any direct connection is made between two pressurized systems, the direction of flow through the connection or interface is dependent on the pressure differential between the systems. If the solar system*

pressure is higher than the potable water supply pressure, boiler water will flow into the potable water distribution system. The exception allows backflow protection to be omitted where potable water flows through the solar system and all components of the solar system are listed for potable water applications.

1401.3 Heat exchangers. Heat exchangers used in domestic water-heating systems shall be approved for the intended use. The system shall have adequate protection to ensure that the potability of the water supply and distribution system is properly safeguarded.

- ❖ *In accordance with the International Plumbing Code® (IPC®), heat exchangers using an essentially toxic transfer fluid must be double-wall construction. An air gap open to the atmosphere must be provided between the two walls. Heat exchangers using an essentially nontoxic transfer fluid may be of singlewall construction.*

The extent of isolation required for a heat exchanger depends on the type of fluid used on the nonpotable side of the heat exchanger. From the definition of “Essentially nontoxic transfer fluid,” the Gosselin rating of the nonpotable fluid must be evaluated. If the fluid has a Gosselin rating of 1, a single-wall heat exchanger is permitted.

The Gosselin rating is a measure of the toxicity of a substance. The name originates from one of the prime developers of the rating system, Dr. Robert E. Gosselin, Professor of Pharmacology at Dartmouth Medical School in New Hampshire.

Gosselin toxicity ratings are the values used by medical personnel to analyze poison victims. The ratings are based on the probable lethal dose for a human. The six levels of Gosselin ratings are outlined in Commentary Table 1401.3(1).

Some of the commercially available transfer fluids with a Gosselin rating of 1 are identified in Commentary Table 1401.3(2).

If the heat transfer fluid has a Gosselin rating of 2 or more, a double-wall heat exchanger is required. The double-wall heat exchanger must have an intermediate space between the walls that is open to the atmosphere. This type of construction would allow any leakage of fluid through the walls of the heat exchanger to discharge externally to the heat exchanger where it would be observable (see Commentary Figure 1401.3).

1401.4 Solar energy equipment and appliances. Solar energy equipment and appliances shall conform to the requirements of this chapter and shall be installed in accordance with the manufacturer’s installation instructions.

- ❖ *All solar energy system components, including collectors, heat transfer fluids and thermal storage units, are regulated by this chapter. The requirements of this chapter address only the potential hazards to life and property associated with solar installations. The system must be installed in accordance with the manufacturer’s installation instructions. Components of the solar system are also required to conform to other applicable sections of the code, such as those found in Chapter 3, General Regulations; Chapter 6, Duct Systems; Chapter 10, Boilers, Water Heaters and Pressure Vessels; Chapter 12, Hydronic Piping; and Chapter 11, Refrigeration. Solar installations could also be subject to provisions in the IPC and the IBC. Included are indirect waste piping and special waste; water supply and distribution; inspection; tests and maintenance; fire-resistant and roof structures; structural loads; glass and glazing and plastic.*

1401.5 Ducts. Ducts utilized in solar heating and cooling systems shall be constructed and installed in accordance with Chapter 6 of this code.

- ❖ *Solar systems can involve hot-air-type collectors, thermal storage systems, fan-coil units and air handlers, all of which may be connected to ductwork.*

SECTION 1402 INSTALLATION

1402.1 Access. Access shall be provided to solar energy *equipment* and appliances for maintenance. Solar systems and appurtenances shall not obstruct or interfere with the operation of any doors, windows or other building components requiring operation or access.

- ❖ *In accordance with the definition of "Access" found in Chapter 2, access to solar energy equipment may be through an access panel, door or similar construction. The installation of solar equipment must also comply with the access-related installation requirements found in Section 306. The installation of solar equipment and piping must not interfere with door swings, operability of windows and access to other equipment and appliances.*

1402.2 Protection of equipment. Solar *equipment* exposed to vehicular traffic shall be installed not less than 6 feet (1829 mm) above the finished floor.

Exception: This section shall not apply where the *equipment* is protected from motor vehicle impact.

- ❖ *The same requirement exists in Section 304.6 (see commentary, Section 304.6).*

1402.3 Controlling condensation. Where attics or structural spaces are part of a passive solar system, ventilation of such spaces, as required by Section 406, is not required where other *approved* means of controlling condensation are provided.

- ❖ *As shown in Commentary Figure 1402.3, some passive solar energy systems use structural cavities, such as attics, crawl spaces and wall and floor spaces, to convey heated air from the collector to or around the conditioned space.*

Attics, crawl spaces, rafter cavities and similar spaces in a building must be ventilated to control moisture and prevent structural damage that can result from high humidity and condensation. Such ventilation could interfere with or reduce the effectiveness of a solar energy system if the spaces being ventilated are also used as air plenums or ducts as part of the solar energy system. This section simply allows omitting the required ventilation of such spaces where the ventilation would affect the operation of the passive solar system and where an effective method of moisture control is substituted for the otherwise required ventilation.

Moisture in attics and structural spaces could possibly be controlled by the air currents of a passive solar system, or the space could be mechanically ventilated in accordance with Section 406 of the code. Possibly, moisture control will not be necessary where such spaces are sufficiently heated by the operation of the solar energy system. The intent is to permit any method or combination of methods that will prevent moisture accumulation and resulting damage to the structure and allow the structural space to serve as part of the solar system.

1402.4 Roof-mounted collectors. Roof-mounted solar collectors that also serve as a roof covering shall conform to the requirements for roof coverings in accordance with the *International Building Code*.

Exception: The use of plastic solar collector covers shall be limited to those *approved* plastics meeting the requirements for plastic roof panels in the *International Building Code*.

- ❖ *Solar collectors that are an integral part of a roof covering are required to comply with the provisions for roofs and roof structures in the IBC because they function as a solar collector, as well as providing weather protection. These requirements include fire classification, weather protection, wind resistance and durability. Typical collector designs are shown in Commentary Figure 1402.4.*

Solar collectors can be independent assemblies that mount directly on the roof surface or they can be built in as an integral part of the roof covering system.

The exception to this section recognizes that the IBC permits the limited use of plastic roof panels as part of a roof-covering system. Therefore, solar collectors with plastic glazing (covers) comprising part of the roof-covering system should be permitted with the same limitations as plastic roof panels.

1402.4.1 Collectors mounted above the roof. When mounted on or above the roof covering, the collector array and supporting construction shall be constructed of noncombustible materials or fire-retardant-treated wood conforming to the *International Building Code* to the extent required for the type of roof construction of the building to which the collectors are accessory.

Exception: The use of plastic solar collector covers shall be limited to those *approved* plastics meeting the requirements for plastic roof panels in the *International Building Code*.

- ❖ *Solar collectors and any supporting construction mounted on or above the roof covering must be constructed of materials consistent with the building's construction classification.*

Rarely does the existing roof structure face the correct direction or have the desired angle of inclination for solar applications. Therefore, solar collectors or collector arrays are often mounted on support structures on or above a roof to allow the orientation of the collectors for optimum solar exposure. The collectors and any support structure must be constructed of materials permitted for the roof structure on which they are mounted.

The exception allows the use of approved plastic glazing (covers) on solar collectors, if their use falls within the parameters of the IBC. Plastic is combustible, and the intent of this exception is to allow the limited use of combustible collector covers where noncombustible or limited combustible collectors and supports would otherwise be required by the IBC. Plastic collector covers are subject to the same regulations as those for plastic-glazed skylight assemblies.

1402.5 Equipment. The solar energy system shall be equipped in accordance with the requirements of Sections 1402.5.1 through 1402.5.4.

- ❖ *Solar energy systems must be designed and properly equipped to protect the system, the building and its occupants from damage and the potential hazards associated with such systems.*

1402.5.1 Pressure and temperature. Solar energy system components containing pressurized fluids shall be protected against pressures and temperatures exceeding design limitations with a pressure and temperature relief valve. Each section of the system in which excessive pressures are capable of developing shall have a relief device located so that a section cannot be valved off or otherwise isolated from a relief device. Relief valves shall comply with the requirements of Section 1006.4 and discharge in accordance with Section 1006.6.

- ❖ *Any heated, closed system is capable of developing pressures that exceed its design working pressure. Closed liquid-filled systems can develop high hydrostatic pressures with even slight temperature increases. Because solar energy varies in intensity, the collector system is subject to greater temperature and pressure variations than other heating systems having precisely controlled energy inputs. Additionally, the solar energy input cannot be turned off by limit controls as can other energy sources. Therefore, a solar energy system is more likely to be subjected to extreme temperatures and pressures that could cause system failures and the associated hazards. Pressure and temperature relief valves are necessary to prevent injury and property damage that could result from the failure of pressurized vessels and piping. Typical liquid solar energy systems involve large complex piping circuits with valve arrangements that greatly increase the likelihood of portions of the piping system being isolated from the overpressure or overtemperature safety devices. Any portion of a system isolated from the relief valve or valves is unprotected from the danger of excessive pressures and temperatures. To ensure complete protection to all portions of a system, multiple relief valves at different locations in the system may be necessary.*

Solar heating and cooling systems are similar in nature to hydronic heating systems; therefore, the requirements for relief valves are the same for both types of systems (see Commentary Figure 1402.5.1). Temperature and pressure relief valves must comply with the provisions of Section 1006.4 for labeling, capacity rating and pressure setting. The discharge of relief valves must meet the requirements of Section 1006.6.

1402.5.2 Vacuum. The solar energy system components that are subjected to a vacuum while in operation or during shutdown shall be designed to withstand such vacuum or shall be protected with vacuum relief valves.

- ❖ *Some solar system designs using a heat transfer fluid capable of freezing employ a method of freeze protection that drains the fluid from the portions of the system exposed to freezing temperatures. Under certain conditions, this draindown function can produce significant partial vacuums in the system. Some solar system designs depend on the vaporization of a liquid heat transfer medium, possibly producing a partial vacuum that is caused by condensation of the transfer medium. These systems can also rely on a constant partial vacuum to lower the boiling point of the liquid transfer medium. Systems subject to pressures below atmospheric pressures must be able to withstand the*

pressure without damage; otherwise, vacuum relief devices are required where systems cannot tolerate the negative pressures that could develop in the system.

1402.5.3 Protection from freezing. System components shall be protected from damage by freezing of heat transfer liquids at the lowest ambient temperatures that will be encountered during the operation of the system.

- ❖ *In liquid solar energy systems, freezing is a common cause of system failure. Because solar collectors can reradiate heat into the cold night sky, it is possible for systems to cool faster than the ambient air, thus freezing a water-filled system when the ambient air temperature is above 32°F (0°C). This section requires protection in areas where freezing of the heat transfer fluid can occur. One of the most frequently used and dependable freeze protection methods is the use of an antifreeze heat transfer fluid. The most commonly used nonfreezing heat transfer fluids are water with ethylene glycol and water with propylene glycol antifreeze solutions. Other nonfreezing heat transfer fluids that can be used are silicone oils, hydrocarbon oils or refrigerants. Some antifreeze solutions are toxic, and the use of toxic heat transfer fluids would require special precautionary means to protect the potable water system from contamination. Other common freeze protection methods include draindown and recirculation. Draindown is a method that automatically or manually drains the heat transfer fluid from the collectors and piping where a potential freezing condition exists (see Commentary Figure 1402.5.3). In areas where freezing temperatures are rare, freeze protection might be accomplished by recirculation of the water from the heat storage system through collectors, as often or at a rate necessary to keep the exposed portions of the system above freezing. Both the draindown and recirculation means of freeze protection rely on electrical and mechanical devices and components or on human action and, therefore, are less dependable than freezeproof heat transfer fluids.*

1402.5.4 Expansion tanks. Liquid single-phase solar energy systems shall be equipped with expansion tanks sized in accordance with Section 1009.

- ❖ *In a liquid, single-phase solar energy system that uses a heat transfer fluid that does not change into a gaseous or solid phase, the heat transfer liquid expands as the temperature increases. An expansion (compression) tank is necessary to receive the expanded liquid, thus preventing excessive pressure increases that would cause system damage or opening of a pressure relief valve. The tank must be sized as required for hydronic systems.*

1402.6 Penetrations. Roof and wall penetrations shall be flashed and sealed to prevent entry of water, rodents and insects.

- ❖ *Typical solar collector arrays will involve one or more roof or wall penetrations to accommodate piping and ducts. The collector arrays could also involve roof covering penetrations caused by support framework members or fasteners. Any penetrations through the walls, roof and roof coverings must be sealed by a waterproof material or*

flashing that will withstand the temperatures produced by the solar energy equipment to which it is exposed and provide weather protection against water penetration.

1402.7 Filtering. Air transported to occupied spaces through rock or dust-producing materials by means other than natural convection shall be filtered at the outlet from the heat storage system.

- ❖ *This section requires filtering to remove dust and particulates from mechanically forced air that has passed through a thermal storage unit containing pebbles, rock or other thermal mass material producing air-borne particles. In passive systems, a filter is not required because the velocity of the air is generally not sufficient to carry particulates or keep larger particles in suspension. Additionally, the resistance offered by an air filter medium would greatly impede natural convective airflow.*

SECTION 1403 HEAT TRANSFER FLUIDS

1403.1 Flash point. The flash point of the actual heat transfer fluid utilized in a solar system shall be not less than 50°F (28°C) above the design maximum nonoperating (no-flow) temperature of the fluid attained in the collector.

- ❖ *Heat transfer liquid is the “working fluid” in the solar heating or cooling system. The liquid is pumped from the thermal energy collector where heat is absorbed by the liquid, to the heat exchanger where the liquid releases the heat energy to another fluid, airstream or some form of thermal storage mass. Some of the commonly used heat transfer fluids are water, water/ ethylene glycol, water/propylene glycol, silicone oils, paraffinic oils and aromatic oils. The term “flash point” applies only to flammable and combustible liquids, and is defined as the minimum temperature at which the liquid gives off enough vapor to form an ignitable mixture with air near the surface of the liquid or within the test vessel used. This section regulates the use of combustible heat transfer liquids and does not apply to flammable liquids because they are prohibited by Section 1403.2. The design parameters of the solar energy system determine the minimum allowable flash point temperature of the heat transfer fluid. See the definitions of “Combustible liquids” and “Flammable liquids” in Chapter 2. The heat transfer fluid’s flash point must be at least 50°F (28°C) above the maximum design temperature that the fluid could reach in the collector during the nonoperating (noflow) phase of the solar energy system operating cycle. This requirement establishes a safety margin by setting the flash point temperature at least 50°F (28°C) above the worst-case temperature that could be reached in the system, which is the no-flow temperature of the fluid in the solar collector at the peak radiation period.*

1403.2 Flammable gases and liquids. A flammable liquid or gas shall not be utilized as a heat transfer fluid. The flash point of liquids used in occupancies classified in Group H or F shall not be lower unless approved.

- ❖ *This section prohibits the use of any heat transfer fluid defined as a “flammable liquid” or a “flammable gas.” Liquids that have a flash point at or above 100°F (38°C) are*

classified as combustible and can be used in solar energy systems within the limitations of Section 1403.1. The relatively high flash points of combustible liquids allow them to be used within the parameters of Section 1403.1. However, flammable liquids have lower flash points and could create a hazard at the temperatures associated with solar energy systems.

Because flammable liquids are not allowed, the lowest permissible flash point would be that of a combustible liquid. The flash point of heat transfer liquids used in factories or in high-hazard occupancies could be lower than the flash points of those liquids classified as combustible when specifically approved by the code official, based on the safety features incorporated into those spaces in recognition of the increased threat of fire. The code allows certain operations and systems to exist in factory, industrial and high-hazard occupancies. It is assumed that such occupancies are periodically inspected for conformance to the fire prevention code, activities are supervised by trained individuals and safety precautions are exercised or incorporated commensurate with the fire hazard. Certain materials and operations could also be necessary as part of a manufacturing process.

SECTION 1404 MATERIALS

1404.1 Collectors. Factory-built collectors shall be *listed* and *labeled*, and bear a label showing the manufacturer's name and address, model number, collector dry weight, collector maximum allowable operating and nonoperating temperatures and pressures, minimum allowable temperatures and the types of heat transfer fluids that are compatible with the collector. The label shall clarify that these specifications apply only to the collector.

- ❖ *Solar collectors can be subjected to high temperatures and pressures, possibly leading to a hazardous condition. As a result, the quality, design and application limitations of the collector must be known to the designer, the installer, the owner and the code official. This section requires that solar collectors be labeled, indicating all maximum and minimum operating and nonoperating pressure and temperature parameters, as well as the manufacturer's name, address, model number and the collector weight, when empty. The label is not only a form of quality assurance but provides the specifications that apply only to the collector and necessary information for its use. Only fluids compatible with the collector are to be used. The misapplication of a collector could result in collector failure, injury to occupants and damage to the property or the structure.*

1404.2 Thermal storage units. Pressurized thermal storage units shall be *listed* and *labeled*, and bear a label showing the manufacturer's name and address, model number, serial number, storage unit maximum and minimum allowable operating temperatures, storage unit maximum and minimum allowable operating pressures and the types of heat transfer fluids compatible with the storage unit. The label shall clarify that these specifications apply only to the thermal storage unit.

- ❖ *Pressurized thermal storage units are containers, tanks or vessels containing some form of thermal mass used to store heat energy collected by the solar system. Thermal storage has two purposes. First, it allows the collector system to continue collecting*

energy when the energy cannot be transferred directly to a load. Second, thermal storage provides useful energy during periods of low or nonexistent insulation (solar radiation). Without thermal storage, any energy that is not simultaneously collected and used would have to be rejected. Thermal storage is often compared to a flywheel because of its ability to store energy temporarily. As with any pressure vessel, the storage unit must be able to withstand safely the pressures and temperatures to which it is exposed. The storage unit must also be compatible with the type of heat transfer fluid used in the system (see commentary, Section 1404.1).

6. 2012 *International Plumbing Code* (IPC):

601.2 Solar energy utilization. Solar energy systems used for heating potable water or using an independent medium for heating potable water shall comply with the applicable requirements of this code. The use of solar energy shall not compromise the requirements for cross connection or protection of the potable water supply system required by this code.

- ❖ **Solar** heating systems consist of two basic types: direct connection and indirect connection. In a direct connection system, the heat transfer fluid is potable water. This type of system has potential safety problems that must be addressed in its design, inspection and maintenance. See the *International Mechanical Code*[®] (IMC[®]) for information on the design and installation of solar heating systems. The main concerns are over contamination of the potable water source from piping and joint materials used in the system and from the inadvertent introduction of nonpotable or toxic transfer fluids at a future date. The use of direct connection systems is typically limited to solar water-heating systems where the potable water is heated directly by the solar collector and circulated through the system, and is suited for use only in areas where the water in the collectors is not subject to freezing.

In an indirect connection system, a freeze-protected heat transfer fluid is circulated through a closed loop to a heat exchanger. The heat is then transferred indirectly to the potable water. The fluids in these systems are not potable and are occasionally toxic. The type of heat exchanger used in these systems depends on the exact nature of the transfer fluid used. As required by Section 608.16.3, a single-wall heat exchanger may be used in systems where the fluid is nontoxic, and a double-wall heat exchanger must be used in systems using toxic fluids.

612.1 Solar systems. The construction, installation, alterations and repair of systems, equipment and appliances intended to utilize solar energy for space heating or cooling, domestic hot water heating, swimming pool heating or process heating shall be in accordance with the *International Mechanical Code*.

- ❖ **Solar** energy can be used for a variety of purposes including space heating, space cooling, domestic water heating, swimming pool heating and process heating. Therefore, the scope encompasses all of these potential solar energy applications and includes the construction, installation, alteration and repair of all systems and equipment.

7. 2012 *International Residential Code* (IRC):

Chapter 2 Definitions

Photovoltaic modules/shingles. A roof covering composed of flat-plate photovoltaic modules or shingles

R905.16 Photovoltaic modules/shingles. The installation of photovoltaic modules/shingles shall comply with the provisions of this section.

- ❖ *The ever increasing number of installations of photovoltaic panels and modules raises concerns about the safety of these installations. This proposal requires these products to be listed and installed in accordance with the manufacturer's instructions. UL 1703 is the standard used to investigate photovoltaic modules and panels, and includes construction and performance requirements to address potential safety hazards. Over 60 companies currently have UL 17032 listings for photovoltaic modules and panels.*

The section provides guidance for installers and code officials regarding the installation of photovoltaic modules/shingles. These shingles are integrated with the building, and provide both a roof covering and source of electrical power. The appropriate design slope and fastening of the shingles are different for each manufacturer's product. For wind resistance, the procedures used in ASTM D3161 for asphalt shingles are appropriate to use, when adapted for these types of shingles.

N1103.9.2 Time switches. Time switches or other control method that can automatically turn off and on heaters and pumps according to a preset schedule shall be installed on all heaters and pumps. Heaters, pumps and motors that have built in timers shall be deemed in compliance with this requirement.

Exceptions:

1. Where public health standards require 24-hour pump operation.
 2. Where pumps are required to operate solar-and waste-heat-recovery pool heating systems.
- ❖ *The use of a time switch or other control method to control the heater and pumps provides an easy system for pool and spa operations and energy savings. The application of Exception 1 is dependent on the requirements of the local health department in the jurisdiction. Because these are often public pools and spas, the health department may require continuous filtering or circulation. Exception 2 grants a credit for using other systems that help the pool and spa operate more efficiently. Therefore, when solar-and waste-heat recovery systems are used to heat the pool, the exception eliminates the time-switch requirement.*

N1103.9.3 Covers. Heated pools and inground permanently installed spas shall be provided with a vapor-retardant cover.

Exception: Pools deriving over 70 percent of the energy for heating from site-recovered energy, such as a heat pump or solar energy source computed over an operating season.

- ❖ *This section states heated pools and inground permanently installed spas are required to have a vapor-retardant cover. This type of cover is not required to provide any minimum level of insulation value. It simply will help hold some of the heat in, much as placing a lid on a pot will help retain the heat. An exception is a vapor-retardant cover is not required for pools deriving over 70 percent of the energy for heating from site-recovered energy, such as a heat pump or solar energy source computed over an operating season.*

Table N1105.5.2 (1) Specifications for the Standard Reference and Proposed Designs

See Table as footnote e for thermal storage element

M2005.1 General. Water heaters shall be installed in accordance with the manufacturer's instructions and the requirements of this code. Water heaters installed in an attic shall comply with the requirements of Section M1305.1.3. Gas-fired water heaters shall comply with the requirements in Chapter 24. Domestic electric water heaters shall comply with UL 732. **Thermal solar** water heaters shall comply with Chapter 23 and UL 174. Solid-fuel-fired water heaters shall comply with UL 2523.

Chapter 23: Solar Systems

General Comments

Chapter 14 contains requirements for the construction, alteration and repair of all systems and components of **solar** energy systems used for space heating or cooling and domestic hot water heating or processing. The provisions of this chapter are limited to those necessary to achieve safe installations that are relatively hazard free.

A **solar** energy system can be designed to handle 100 percent of the energy load of a building, although this is rarely accomplished. Because **solar** energy is a low-intensity energy source and dependent on the weather, it is usually necessary to supplement a **solar** energy system with traditional energy sources.

Solar heating and cooling systems are classified as either passive or active systems. A passive **solar** energy system uses **solar collectors**, a gas or liquid heat-transfer medium and distribution piping or ductwork. This system

does not use circulators or fans but relies on natural (gravity) flow. The flow of energy (heat) is by natural convection, conduction, and radiation. Commentary Figures 23(1) and 23(2) show typical passive **solar** heating applications.

A complete active **solar** energy system includes **solar** collectors, a gas or liquid heat transfer medium, piping, ducts, circulators, fans and controls to move the medium to the load or to an energy storage system. Commentary Figure 23(3) shows a typical active **solar** system used for space and domestic water heating, supplemented by an auxiliary furnace and water heater.

Many design variations exist, such as hybrid systems with components of both active and passive systems. **Solar** systems can act in harmony with the architectural features of the building and can be very complex, or they can be as simple as glazing [see Commentary Figure 23(4)]. **Solar** designs can be used to work with, and im-

prove the performance of, conventional space heating systems. For example, a simple **passive collection system** can greatly improve the performance of an air-to-air or water-to-air heat pump system.

The energy collected by a **solar** system can be used as it is collected or transferred to some form of **thermal storage** system. Typical **thermal storage** systems consist of large quantities of a dense mass, such as stone, masonry or water. Storage mass can also consist of materials in which a phase change occurs, such as chemical compounds that store the latent heat required to liquefy the compounds that are solid at room temperature.

If the energy collected by a **solar** system is not used or stored for later use, and unless the collection system is designed to withstand the higher temperatures and pressures resulting from the static (no-flow) mode of opera-

tion, the collection system must either stop collecting or dump the energy to the building exterior.

The structural loading effect that the collectors and supports have on the building's roof system also must be considered. Collectors can add considerable weight, affect snow accumulation and increase wind loads and uplift forces. As with any roof-mounted equipment or appliances, the installation also must comply with the applicable provisions of the building portions of this code.

Purpose

This chapter establishes provisions for the safe installation, operation and repair of solar energy systems. Although these systems use components similar to those of conventional mechanical equipment, many of these provisions are unique to solar energy systems.

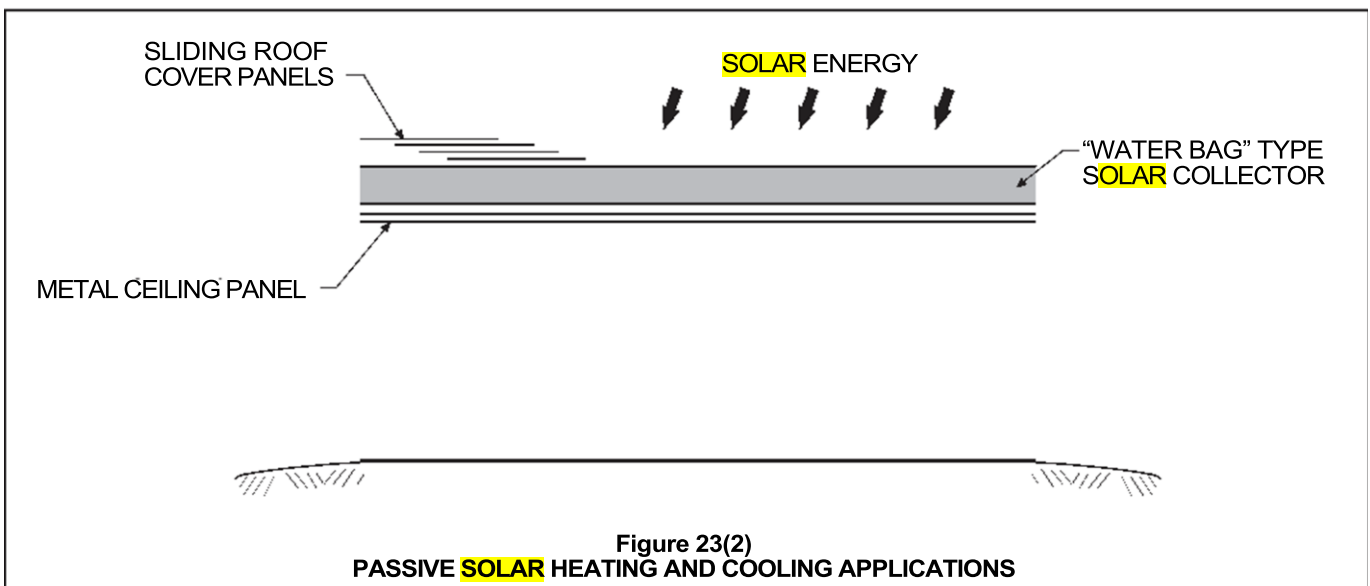
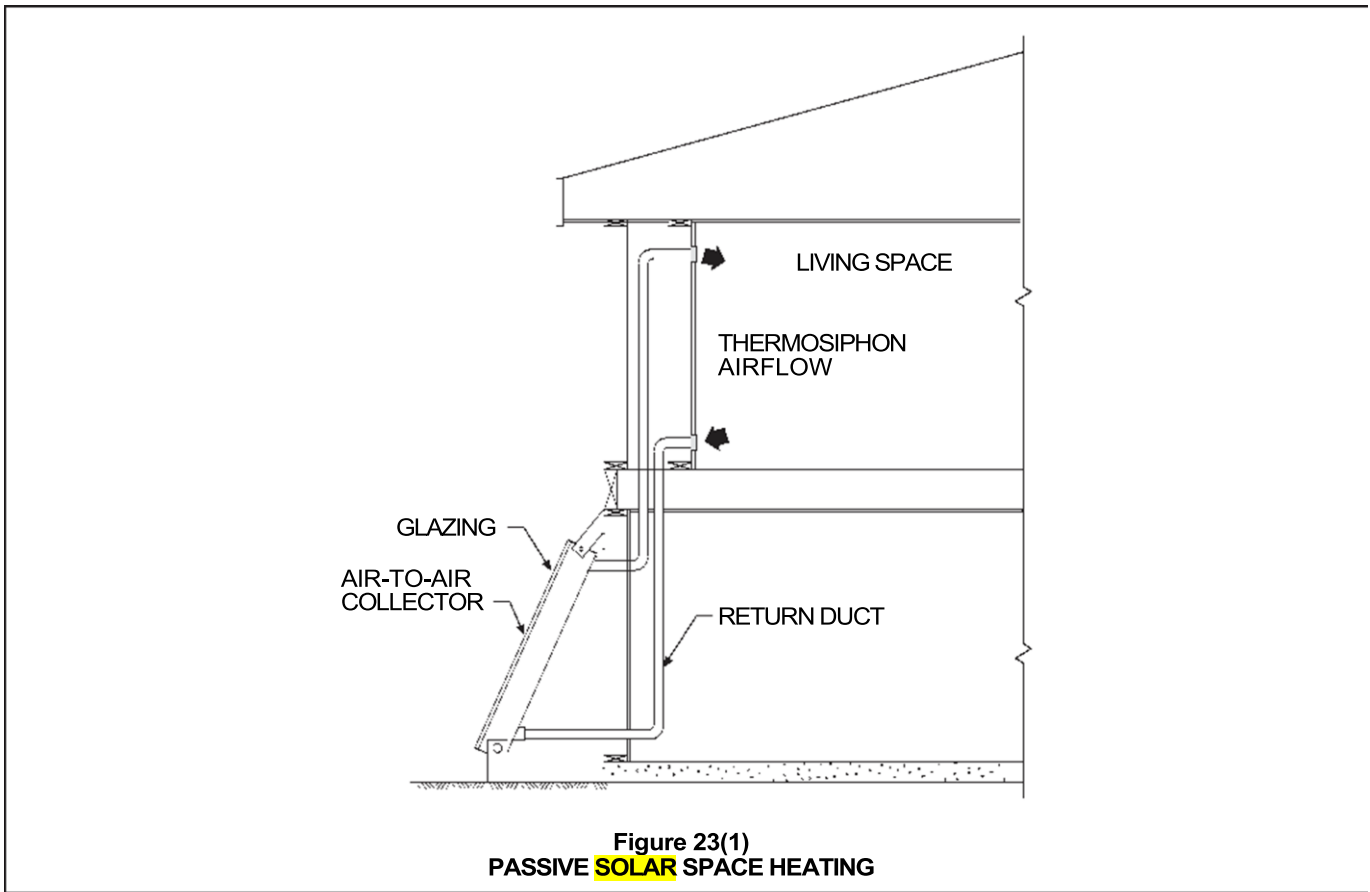

M2301.1 General. This section provides for the design, construction, installation, alteration and repair of equipment and systems using **thermal solar** energy to provide space heating or cooling, hot water heating and swimming pool heating.

- ❖ *The provisions within this section cover the design, installation, construction, alteration and repair of equipment for **thermal solar** systems that heat water for domestic hot water use, space heating and, on rare occasions, space cooling. The IRC also covers the installation of **collector** systems that provide hot water for swimming pools. There are five major components in active **solar** heating systems:*
 - **Collector(s)** to capture **solar** energy. Usually, systems used for space heating will have many more **collectors** than systems designed for domestic water heating only.
 - **Circulation system** to move a fluid between the **collectors** and back through a heat exchanger. The heat exchanger keeps the collection fluid separate from the domestic water.
 - **Storage tank(s)** to collect heated water. This may be a standard water heater or a

separate unfired hot water storage tank located next to the water heater.

- *Backup heating system. For domestic water heating this will usually be a hot water heater. Backup space-heating systems may consist of electric baseboard heating or a gas or electric heater.*
- *Control system to regulate overall system operation. The control system will include valves and shutoff devices to protect from excessively high temperatures.*

M2301.2 Installation. Installation of **solar** energy systems shall comply with Sections M2301 .2.1 through M2301.2.9.

- ❖ *The requirements of this chapter address the potential hazards to life and property associated with solar installations only. The system must be installed in accordance with the manufacturer's installation instructions. Components of the **solar** system must also conform to other applicable sections of the code.*

M2301.2.1 Access. **Solar** energy collectors, controls, dampers, fans, blowers and pumps shall be accessible for inspection, maintenance, repair

and replacement.

- ❖ *This section requires that solar collectors, controls, dampers, fans, blowers and pumps associated with the solar system be accessible for inspection, maintenance, repair and replacement. The collection system pumps and controls are often located in the garage or pool equipment building, allowing easy access for the inspector, and are mounted in close proximity to each other. While not a code requirement, it is beneficial to have operation and maintenance manuals available to the owner once the system is installed.*

M2301.2.2 Roof-mounted collectors. The roof shall be constructed to support the loads imposed by roof-mounted solar collectors. Roof-mounted solar collectors that serve as a roof covering shall conform to the requirements for roof coverings in Chapter 9 of this code. Where mounted on or above the roof coverings, the collectors and supporting structure shall be constructed of noncombustible materials or fire-retardant-treated wood equivalent to that required for the roof construction.

- ❖ *Roof mounted solar collectors can be designed to be installed integral with the roof, thereby serving as the roof covering. They can also be mounted on or above the roof*

covering. Systems that are installed as a roof covering must be watertight and properly flashed, in addition to meeting the other requirements applicable to the installation in Chapter 9 of this code. Systems installed on or above the roof covering must be securely fastened to the roof/rafter system. Often, solar collector systems are installed with manufactured metal mounting brackets that can be attached to the roofing system or wood blocking, or with sleepers using lag bolts or other secure mounting systems. The manufacturer's mounting specifications must be followed so that the panels are properly mounted. This is especially important in areas with high wind loads. Also, the weight of the collector system must be checked (when operational and filled with fluid) to confirm that the roof structure is designed to meet the increased load.

Most manufactured panel systems used for domestic hot water are constructed using a metal housing to hold the collection system. This housing must meet the requirements for noncombustible materials. Panel systems constructed on site by the owner/builder that use a housing made of wood may or may not meet the requirements for noncombustible materials.

M2301.2.3 Pressure and temperature relief.

System components containing fluids shall be protected with pressure- and temperature-relief valves. Relief devices shall be installed in sections of the system so that a section cannot be valved off or isolated from a relief device.

- ❖ . Pressure and temperature relief valves are important to prevent pipes bursting because of high collector temperatures. Flat plate collectors used for domestic water systems are designed with glass coverings and an insulated housing to increase the efficiency of the collection system. The collection surface, or absorber plate, can easily heat up to 200° F (93°C) on a freezing winter day and up to 400°F (204°C) on a summer day when the water is stagnant and not circulated through the collector. These valves are often installed as part of the collector system. These valves must also be installed on the storage tank and back-up water heater.

M2301.2.4 Vacuum relief. System components that might be subjected to pressure drops below atmospheric pressure during operation or shutdown shall be protected by a vacuum-relief valve.

- ❖ This section requires thermal solar systems that

might be subjected to pressure drops below atmospheric pressure during operation or shutdown to be protected by a vacuum relief valve. Vacuum relief valves can be used in conjunction with freeze protection valves that drain the collector panels when the temperature reaches close to 32°F (0°C) or a drain down system that automatically drains the collector fluid when the system is shut off. The vacuum relief valve must be mounted higher than the collector panels.

M2301.2.5 Protection from freezing. System components shall be protected from damage resulting from freezing of heat-transfer liquids at the winter design temperature provided in Table R301.2(1). Freeze protection shall be provided by heating, insulation, thermal mass and heat transfer fluids with freeze points lower than the winter design temperature, heat tape or other approved methods, or combinations thereof.

Exception: Where the winter design temperature is greater than 32°F (0°C).

- ❖ *In climates where the design winter temperature is 32°F (0°C) or less, the system must be protected from freezing. The greatest damage that can be done to the collector system is for water to freeze in the collection system, causing the piping to*

break. To meet the intent of the code, an indirect (closed loop) system may be installed. See Section M2301 .1. Various types of collection fluids that have low freezing points can be used in this system. Usually, a double wall heat exchanger is used with this system to transfer the heat from the collector loop to the domestic water loop. This system can be designed to drain the fluid back into the storage tank during periods of nonuse. For a direct (open loop) system, hot water from the storage tank can be circulated through the collector loop to protect the system.

M2301.2.6 Expansion tanks. Expansion tanks in solar energy systems shall be installed in accordance with Section M2003 in closed fluid loops that contain heat transfer fluid.

- ❖ *This section requires installation of pressure tanks in indirect (closed loop) systems. Manufactured systems that are pre-engineered based on the number of panels in the system, storage tank size and circulation pump size often come with a specified expansion tank pressurized for the system. The expansion tank is usually installed next to the pumps, storage tank and controls.*

M2301.2.7 Roof and wall penetrations. Roof and wall penetrations shall be flashed and sealed in accordance with Chapter 9 of this code to prevent entry of water, rodents and insects.

- ❖ *Roof and wall penetrations must be sealed during and after installation of the solar systems. At a minimum, there will be roof penetrations for the supply and return piping going to and from the collector panels. Systems mounted above the roof covering will require penetrations into the rafter system or blocking to attach the collectors to the roof, and care must be taken to seal the holes with a waterproof sealant. Chapter 9 states flashing and waterproofing requirements for several roof types. Wall penetrations below roof overhangs and similar locations where it is unlikely that water will enter must still be sealed to prevent the entry of rodents and insects.*

M2301.2.8 Solar loop isolation. Valves shall be installed to allow the solar collectors to be isolated from the remainder of the system. Each isolation valve shall be labeled with the open and closed position.

- ❖ *This section requires installation of valves so that the solar collectors are isolated from the remainder of the system. Gate valves must be installed on both the inlet and outlet side of each bank of collectors (if more than one) so that the collector panel(s) can be removed for repair. Although it is not a requirement of the code, it is advantageous to install valves so that the circulation pump and storage tank can each be isolated and so that the solar loop can be bypassed completely.*

M2301.2.9 Maximum temperature limitation. Systems shall be equipped with means to limit the maximum water temperature of the system fluid entering or exchanging heat with any pressurized vessel inside the dwelling to 180°F (82°C). This protection is in addition to the required temperature- and pressure-relief valves required by Section M2301.2.3.

- ❖ *To prevent potential problems with clearances to combustibles and to prevent burn injuries resulting from human contact with piping or pressure vessels, the system fluid temperature is limited to 180°F (82°C) if it enters any pressurized vessel inside a dwelling. The method of limiting the temperature is to be determined by the designer or system installer. Possible methods include a system to bypass the solar collector or a rejection heat exchanger outside the dwelling.*

M2301.3 Labeling. Labeling shall comply with Sections M2301.3.1 and M2301.3.2.

- ❖ *The designer, installer, owner and building official must know the quality, design and application limitations of the collector and thermal storage units. This section requires that they be labeled. The label is a form of quality assurance and lists specifications that apply only to the equipment, as well as necessary information for its use.*

M2301.3.1 Collectors. Collectors shall be listed and labeled to show the manufacturer's name, model number, serial number, collector weight, collector maximum allowable temperatures and pressures, and the type of heat transfer fluids that are compatible with the collector. The label shall clarify that these specifications apply only to the collector.

- ❖ *Solar collectors must be listed and labeled to show the manufacturer's name, model number,*

serial number, collector weight, collector maximum allowable temperatures and pressures and the type of heat transfer fluids that are compatible with the collector. The Solar Rating and Certification Corporation (SRCC) is one entity that provides a third party certification that will meet the requirements of this provision. The Directory of SRCC Certified Solar Collector System Ratings, Directory of SRCC Certified Water Heating System Ratings and Summary of SRCC Certified Solar Collector and Water Heating System Ratings are published by the SRCC annually and list all the information required for this provision except for the serial number, which can be found on the collector.

M2301.3.2 Thermal storage units. Pressurized thermal storage units shall be listed and labeled to show the manufacturer's name, model number, serial number, storage unit maximum and minimum allowable operating temperatures and pressures, and the type of heat transfer fluids that are compatible with the storage unit. The label shall clarify that these specifications apply only to the thermal storage unit.

- ❖ Pressurized thermal storage units must bear a listing and label that discloses the manufacturer's name, model, serial number and important operating characteristics such as operating temperatures and pressures, and the type of heat transfer fluid. The information is important for servicing, repairs and inspection.

M2301.4 Prohibited heat transfer fluids. Flammable gases and liquids shall not be used as heat transfer fluids.

- ❖ Flammable gases or flammable liquids must not be used as heat transfer fluids. Solar energy systems generate large amounts of heat that could ignite flammable materials in the event of a malfunction.

M2301.5 Backflow protection. Connections from the potable water supply to solar systems shall comply with Section P2902.55.

- ❖ The potable water supply connected to a solar system must be equipped with a backflow preventer with an intermediate atmospheric vent.

Refer to Section P2902.5.5 for a discussion of this requirement.

Section M2302 Photovoltaic Solar Energy Systems

M2302.1 General. This section provides for the design, construction, installation, alteration, and repair of photovoltaic equipment and systems.

- ❖ *The provisions within this section cover the design, installation, construction, alteration and repair of equipment for photovoltaic solar systems. With the ever-increasing demand for alternative power sources, one of the most popular of these is solar photovoltaic (PV) power systems. A number of United States electric utility power suppliers offer incentives for the installation of PV systems on buildings because such systems offer the property*

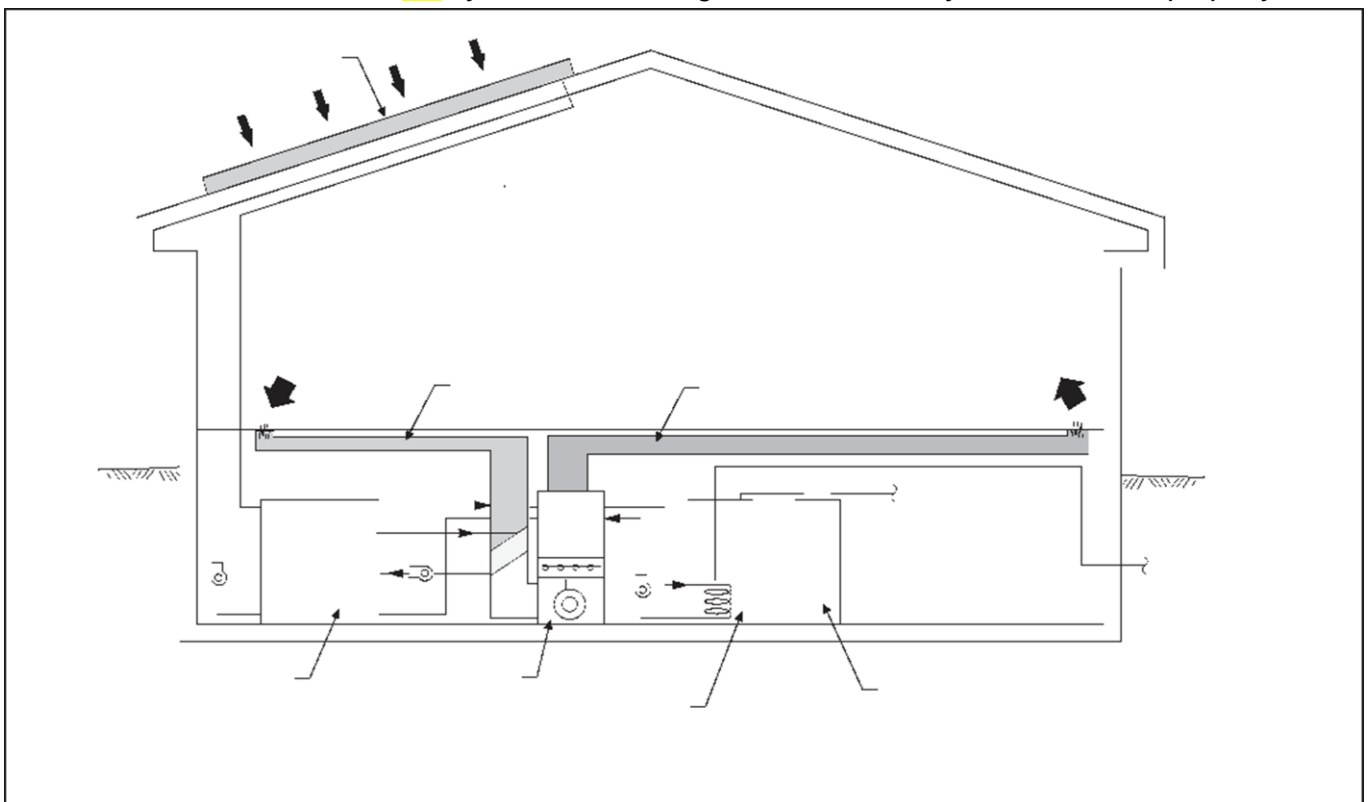

owners the

Figure 23(3) ACTIVE SPACE AND DOMESTIC WATER HEATING SYSTEM

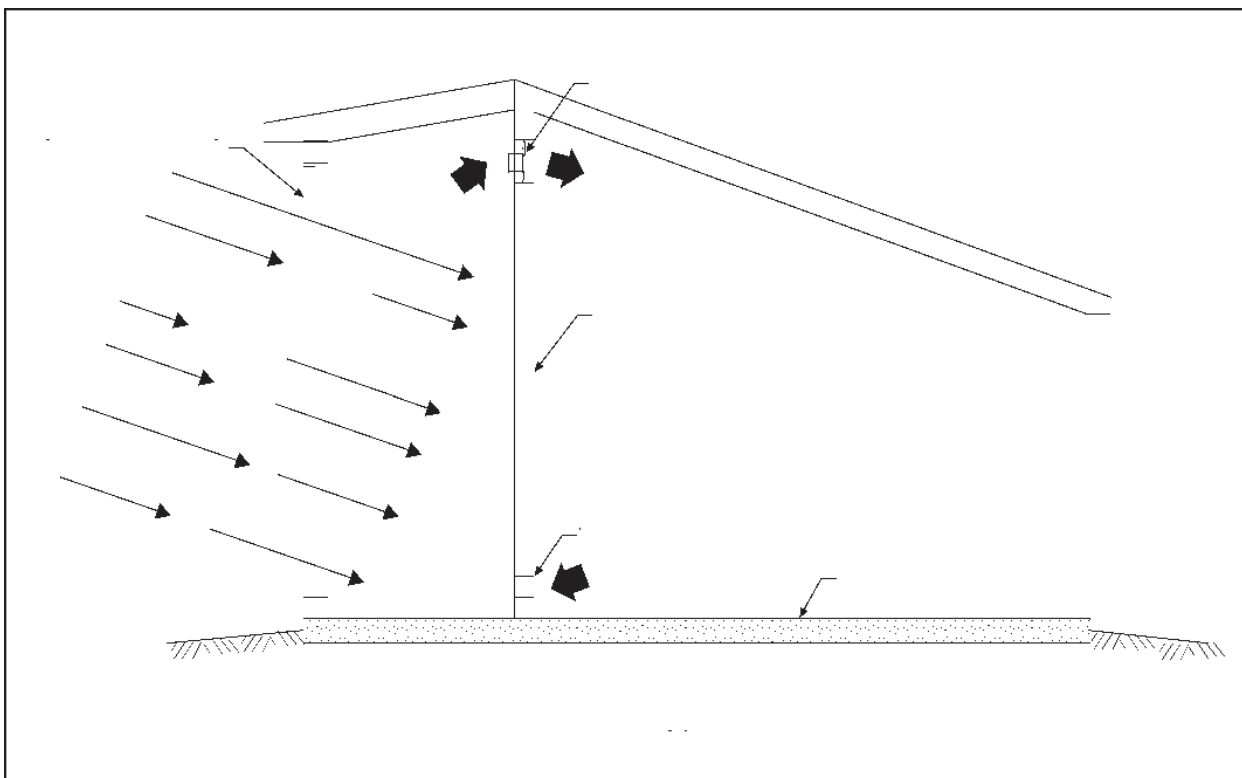

Figure 23(4) PASSIVE COLLECTION WITH MECHANICAL DISTRIBUTION

owners the ability to generate their own electricity and in many cases, sell excess electricity back to the utility provider. Such an arrangement is a benefit to the utility provider because it reduces their power generation demand, which in turn can control the rates that commercial and residential customers pay. Demand in the past decade for PV power systems has increased by several orders of magnitude. According to U.S. Energy Information Administration, approximately 21,200 PV cells and modules were shipped domestically in 1999 – in 2008, the number shipped was over 524,200. As the number of PV power systems increases, economy of scale will continue to reduce their costs, making these systems more common on residential buildings.

PV systems are designed to convert light energy into direct current (DC) electricity. They have no moving parts and do not contain fluids. The light-to-electricity conversion begins at the PV cell, which is commonly a semiconductor device that generates electricity when exposed to light. To be effective PV cells are assembled into PV modules, which are then assembled into PV panels. These panels are then assembled onto a frame or a flexible substrate which can be affixed to the roof of buildings to create a PV array. The PV arrays and its modules are wired together and generally operate as series electrical circuit. An inverter is used to convert the DC power into alternating current (AC) that can be used to power the electrical devices in the dwelling.

M2302.2 Requirements. The installation, inspection, maintenance, repair and replacement of photovoltaic systems and all system components shall comply with the manufacturer's instructions, Sections M2302.2.1 through M2302.2.3 and NFPA 70.

- ❖ *The requirements of this chapter address the potential hazards to life and property associated with photovoltaic systems. The system must be installed in accordance with the manufacturer's installation instructions. Components of the solar system must also conform to other applicable sections of the code.*

M2302.2.1 Roof-mounted panels and modules. Where photovoltaic panels and modules are installed on roofs, the roof shall be constructed to support the loads imposed by such modules. Roof-mounted photovoltaic panels and modules that serve as roof coverings shall conform to the requirements for roof coverings in Chapter 9. Where mounted on or above the roof coverings, the photovoltaic panels and modules and supporting structure shall be constructed of noncombustible materials or fire-retardant-treated wood equivalent to that required for the roof construction.

- ❖ *Roof mounted solar collectors can be designed to be installed integral with the roof, thereby serving as the roof covering. They can also be mounted on or above the roof covering. Systems that are installed as a roof covering must be watertight and properly flashed, in addition to meeting the other requirements applicable to the installation of roof coverings in Chapter 9 of this code. These requirements include fire classification, weather protection, wind resistance and durability. Systems installed on or above the roof covering must be securely fastened to the roof/rafter system. Often, solar collector systems are installed with manufactured metal mounting brackets that can be attached to the roofing system or wood blocking, or with sleepers using lag bolts or other secure mounting systems. The manufacturer's mounting specifications must be followed so that the panels are properly mounted. This is especially important in areas with high wind loads. Also, the weight of the collector system must be checked to confirm that the roof structure is designed to meet the increased load. The International Fire Code contains additional requirements for roof mounted solar collectors with respect to firefighter safety and solar panel placement.*

M2302.2.2 Roof and wall penetrations. Roof and wall penetrations shall be flashed and sealed in accordance with Chapter 9 to prevent entry of water, rodents, and insects.

- ❖ *Roof and wall penetrations must be sealed during and after installation of the solar systems. At a minimum, there will be roof penetrations for the electrical conduits connecting to the panels. Systems mounted above the roof covering will require penetrations into the rafter system or blocking to attach the collectors to the roof, and care must be taken to seal the holes with a waterproof sealant. Chapter 9 states flashing and waterproofing requirements for several roof types. Wall penetrations below roof overhangs and similar locations where it is unlikely that water will enter must still be sealed to prevent the entry of rodents and insects.*

M2302.2.3 Ground-mounted panels and modules. Ground-mounted panels and modules shall be installed in accordance with the manufacturer's instructions.

- ❖ *Ground mounted panels and modules must be installed in accordance with the manufacturer's installation instructions which should contain requirements as to the direction and angle of the panels, anchorage to the ground and clearances from other buildings and other structures.*

M2302.3 Photovoltaic panels and modules. Photovoltaic panels and modules shall be

listed and labeled in accordance with UL 1703.

- ❖ *Photovoltaic panels and modules must be listed and labeled by an approved agency to show that they comply with applicable national standards. The label is the primary, if not the only, assurance to the installer, the inspector and the end user that a similar appliance has been tested and evaluated by an approved agency and performed safely and efficiently when installed and operated in accordance with its listing. Photovoltaic panels and modules must be listed and labeled to UL 1703 which is a referenced standard for flat plate photovoltaic modules and panels with a maximum system voltage of 1,000 volts or less.*

M2302.4 Inverters. Inverters shall be listed and labeled in accordance with UL 1741. Systems connected to the utility grid shall use inverters listed for utility interaction.

- ❖ *Photovoltaic (PV) systems are designed to convert light energy into direct current (DC) power. Inverters convert the DC power to AC power which can then be connected to the utility grid which would allow the homeowner to sell excess electricity back to the utility provider. When connected to the grid the inverter must be an anti-islanding inverter. Islanding is a situation where electricity is feed back into the grid during a power outage which can occur when standby generators are in use or a PV system is connected to the grid. When there is a power outage and the utility crews are working on the lines that they believe the power if off, it could be very dangerous for the workers if a PV system is connected to the grid. Anti-islanding inverters are designed to disconnect form the grid in the event of a power outage*

P2902.5.5 Solar system. The potable water supply to a solar system shall be equipped with a backflow preventer with intermediate atmospheric vent complying with ASSE 1012 or a reduced pressure principle backflow preventer complying with ASSE 1013. Where chemicals are used, the potable water supply shall be protected by a reduced pressure principle backflow preventer.

Exception: Where all solar system piping is a part of the potable water distribution system, in accordance with the requirements of the International Plumbing Code, and all components of the piping system are listed for potable water use, cross-connection protection measures shall not be required.

- ❖ *As with fire sprinkler systems, solar systems must be equipped with a backflow preventer with an intermediate atmospheric vent conforming to ASSE 1012. If chemicals or additives are used in the solar system, the more reliable reduced pressure principle backflow prevention assembly conforming to ASSE 103 must be used. Current text requires solar systems to be equipped with a form of backflow prevention device. An exception provides for an installation where the solar system piping is a part of the potable water distribution system, and all components of the piping system are listed for potable water use. The typical solar water heater is designed so that it falls under the exception or the solar portion of the system is isolated from the storage tank by a double-wall heat exchanger.*

8. 2012 International Swimming Pool and Spa Code (ISPSC):

303.4 Covers. Heated pools and inground permanently installed *spas* shall be provided with a vapor retardant cover.

Exception: Where more than 70 percent of the energy for heating, computed over an operating season, is from site recovered energy such as from a heat pump or solar energy source.

Table 316.2 Water heaters

DEVICE	STANDARD
Electric water heater	UL 1261, UL 1563 or CSA C22.2 No. 218.1
Gas-fired water heater	ANSI Z21.56a
Heat exchanger	NSF 50
Heat pump water heater	UL 1995, AHRI 1160, CSA C22.2 No. 236
Photovoltaic solar water heaters	NSF 5
Thermal radiant solar water heater	NSF 50