

DuPont™ Tyvek® Air Barrier Installation Guidelines

HELPING YOU GET THE JOB DONE RIGHT

 Canadian Version



The miracles of science™

VERSION 2

Table of Contents

Applicable Products	2
Required Materials	2
Code Requirements.....	3
General Instructions	3
Special Considerations	3
Installation Instructions.....	4
Foundation/floor connection.....	4
Continuity	
Top of wall connection.....	7
Knee-wall	7
Cantilever Floor.....	7
Roof-wall interface.....	8
Penetrations.....	8
Handling Tears and Holes	9
DuPont™ Flashing Systems Integration	10

Applicable Products

Air Barrier

PRODUCT	DIMENSIONS	AREA
DuPont™ Tyvek® HomeWrap®	3 ft x 100 ft (0.91 m x 30.48 m)	300 sq ft (91.44 m ²)
	5 ft x 200 ft (1.52 m x 60.96 m)	1,000 sq ft (304.80 m ²)
	9 ft x 100 ft (2.74 m x 30.48 m)	900 sq ft (274.32 m ²)
	9 ft x 150 ft (2.74 m x 45.72 m)	1,350 sq ft (411.48 m ²)
	10 ft x 100 ft (3.05 m x 30.48 m)	1,000 sq ft (304.80 m ²)
	10 ft x 150 ft (3.05 m x 45.72 m)	1,500 sq ft (457.20 m ²)
DuPont™ Tyvek® CommercialWrap®	5 ft x 200 ft (1.52 m x 60.96 m)	1,000 sq ft (304.80 m ²)
	10 ft x 125 ft (3.05 m x 38.10 m)	1250 sq ft (381 m ²)
DuPont™ Tyvek® HeaderWrap®		

CCMC Approved Sheathing Tapes

PRODUCT
CCMC 13123-R: Intertape Polymer's Sheathing Tape
CCMC 11955-R: Tuck 20502 Contractor's Sheathing Tape

Required Materials

- DuPont™ Tyvek® Air Barrier
- CCMC approved sheathing tape
- DuPont™ Tyvek® Wrap Caps or other 1" (25 mm) cap fastener (see step 3)
- Compatible Caulks and Sealants – See the DuPont Building Science Bulletin "Compatibility Guidelines for Building Sealants" for additional guidance.
- Vertical furring strips on stud lines (i.e. strapping) where rainscreen is desired or required by code.

Air Barrier Code Requirements

The 2005 National Building Code (NBC) of Canada (Sections 5.4 and 9.25.3) requires air barrier systems to be included in thermally insulated wall assemblies. The materials *“intended to provide the principal resistance to air leakage shall have air leakage characteristics not greater than .02 L(s•m²) measured at an air pressure difference of 75 Pa”*. DuPont™ Tyvek® air barriers perform as air barrier materials as recognized in the following CCMC evaluation reports:

- CCMC 12857-R DuPont™ Tyvek® HomeWrap® – Air Barrier Material™
- CCMC 13253-R DuPont™ Tyvek® CommercialWrap® – Air Barrier Material™

Air barrier systems shall be continuous across junctions between different building assemblies and around penetrations in the building assembly. This guide provides information on installing DuPont™ Tyvek® air barriers to achieve this continuity.

General Instructions

The most effective time to install DuPont™ Tyvek® air barriers is when:

- walls are constructed
- step flashings and kickout flashings are installed
- **BEFORE** the windows and doors are set

If you want to install windows and doors prior to the air barrier, please refer to the DuPont™ Flashing Systems Installation Guidelines, Flashing **BEFORE** air barrier section which will direct you back to this guide at the appropriate step.

If the house has windows and doors already installed and they are flashed **be sure to integrate the air barrier by following the DuPont™ Flashing Systems Integration section in this guide.**

Note: If DuPont™ FlexWrap™ and apron are used, install the air barrier under the apron with DuPont™ Tyvek® and ensure proper shingling. If a non-self adhering sill flashing product is used, please maintain proper shingling.

Special Considerations

1. DuPont requires that DuPont™ Tyvek® HomeWrap® and DuPont™ Tyvek® HeaderWrap® be covered within 4 months (120 days) of its installation.
2. DuPont requires that DuPont™ Tyvek® CommercialWrap® be covered within 9 months (270 days) of its installation.

Installation Instructions

Start at the bottom of the structure to ensure proper shingling occurs throughout the installation. Proper shingling is required to provide for water shedding and to prevent water entering the wall system.

STEP 1

Foundation / Floor Connection

The foundation wall is part of the air barrier system. Install DuPont™ Tyvek® HeaderWrap® (or appropriately cut width of DuPont™ Tyvek®) on sill gasket and foundation wall. Seal DuPont™ Tyvek® onto the inside wall to hold in place. Build floor structure and wrap DuPont™ Tyvek® up and around floor joist as shown below. DuPont™ Tyvek® must be shingled over flashing and taped to properly drain any rain that penetrates the cladding.

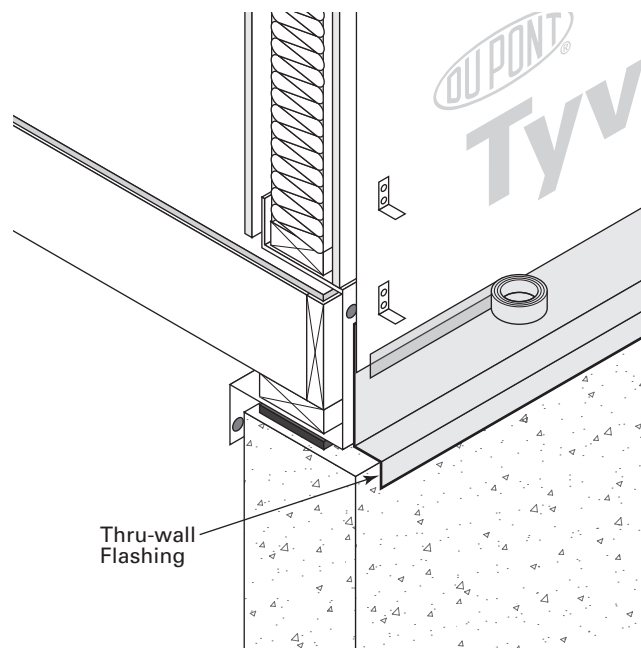

STEP 2

Start wrapping at the bottom of the structure to ensure proper shingling with the wrapped foundation. Proper shingling is required to provide for water shedding and to help prevent water entering the wall system.

STEP 3

UNWRAP roll at corner, leaving 6" to 12" (150 to 300 mm) vertical overlap.

Printed stud marks are available on some DuPont™ Tyvek® products to aid in aligning with the studs. (e.g. studmarks are 8" (200 mm) apart for DuPont™ Tyvek® HomeWrap®)

STEP 4

Roll should be plumb. Bottom edge of roll should extend over sill plate interface at least 2" (150 mm). Extend to bottom of sill plate for slab on grade foundations. For stucco exteriors integrate with weep screed.

STEP 5

As with all air barriers, DuPont™ Tyvek® can be secured to the exterior sheathing by either of the following methods.

Method A: Continuous furring strips shall be installed vertically along stud lines.

Method B: Cap-nails shall be installed along stud lines at 6" (150mm) O.C. Additional cap-nails should be installed to support DuPont™ Tyvek® bridging across any opening in the sheathing board.

Brick ties can be substituted for cap-nails in masonry veneer construction.

Note: Do not fasten within 9" (225 mm) of rough opening head.

STEP 6

Unroll directly over windows and doors. Upper layer of air barrier should overlap bottom layer of air barrier by a minimum of 6" (150 mm).

Refer to the DuPont™ Flashing Systems Installation Guidelines to prepare and flash window and door opening.

Note: If windows are already installed, the DuPont™ Tyvek® air barrier shall be integrated with proper shingling with window flashings. If DuPont™ FlexWrap™ and apron are used, install the air barrier under the apron to ensure proper shingling. If non-self adhering sill flashing is used, install the air barrier under the bottom of the sill flashing to maintain proper shingling.

STEP 7

All vertical and horizontal seams shall be taped with approved tape.

Taping all vertical and horizontal seams is part of the requirement to obtain the DuPont™ Tyvek® Products Material and Labor Residential 10-year Limited Warranty.

STEP 8

After the air barrier is installed, refer to the DuPont™ Flashing Systems Installation Guidelines to prepare and flash windows and doors.

DuPont™ Tyvek® Air Barrier Installation Guidelines

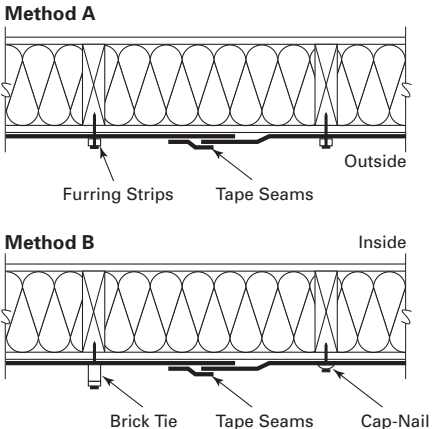
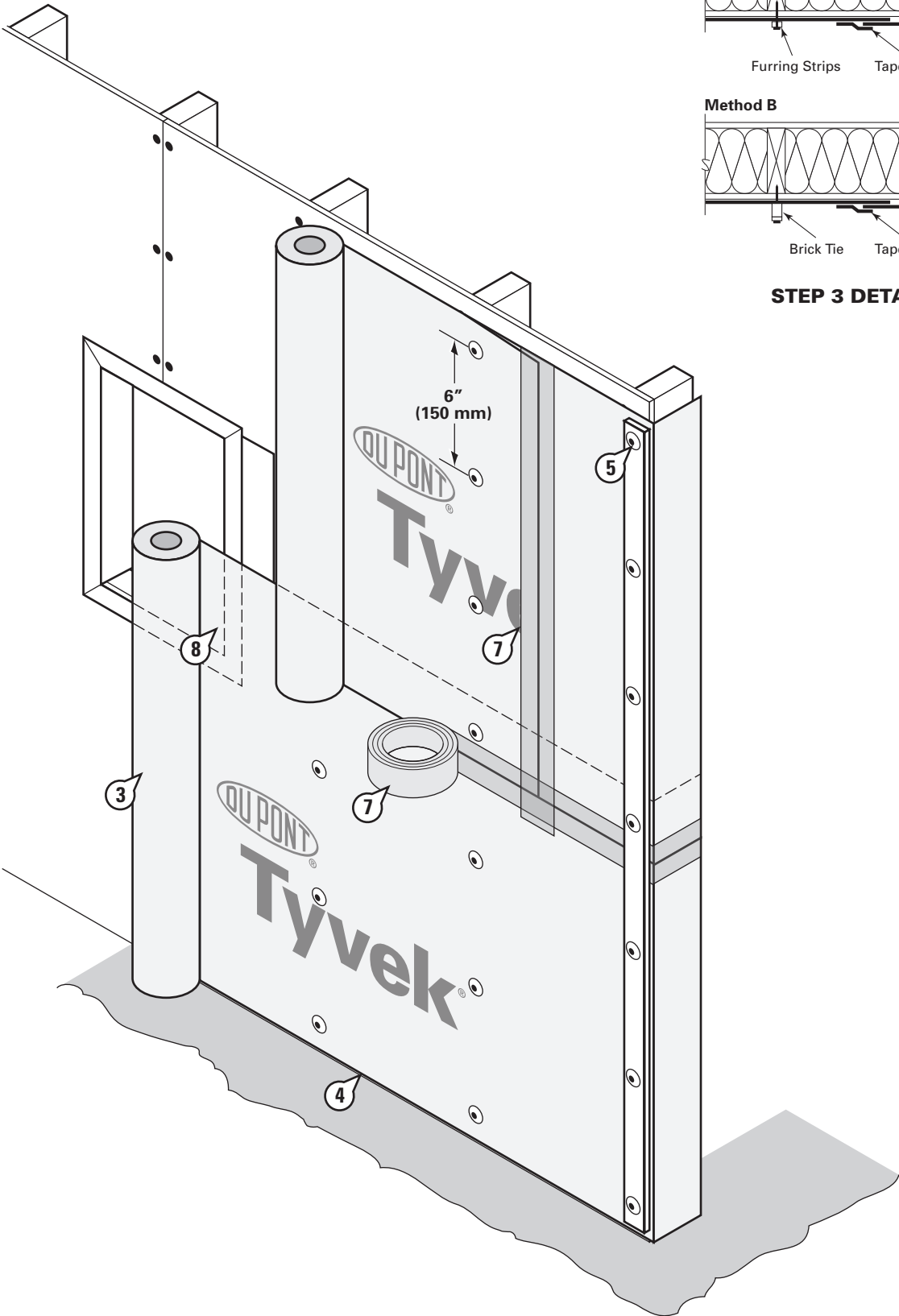

STEP 3 DETAIL VIEW

Continuity

Top of Wall Connection

To ensure continuity of the air barrier membrane, DuPont™ Tyvek® shall be installed as shown in the drawing.

The ceiling and wall air barrier membranes shall be overlapped and sealed with a continuous strip of tape.

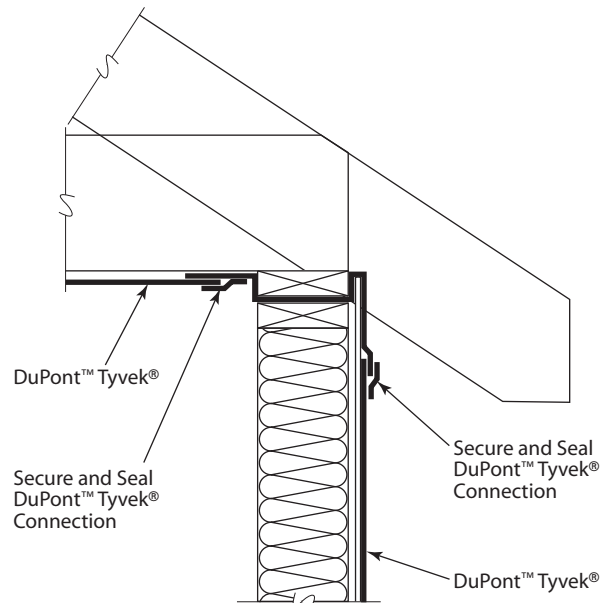

Knee-wall

Coordination of roof and knee-wall construction is important to ensure continuity of the air barrier.

Support and fasten DuPont™ Tyvek® over lower floor ceiling area.

Tape all seams that may arise due to construction.

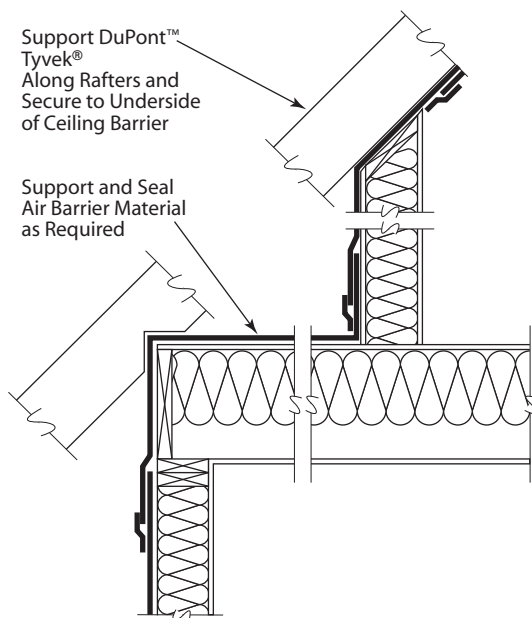

Cantilever Floor

Wrap the DuPont™ Tyvek® under and up the Cantilever floor and fold the DuPont™ Tyvek® up the sides of the Cantilever wall a minimum of 6" (150 mm). Tape all corners. Top layer of air barrier should go over bottom layer a minimum of 6" (150 mm).

Note: Get the inside corner as tight as possible using a 1x4 (25 x 100 mm) or similar.

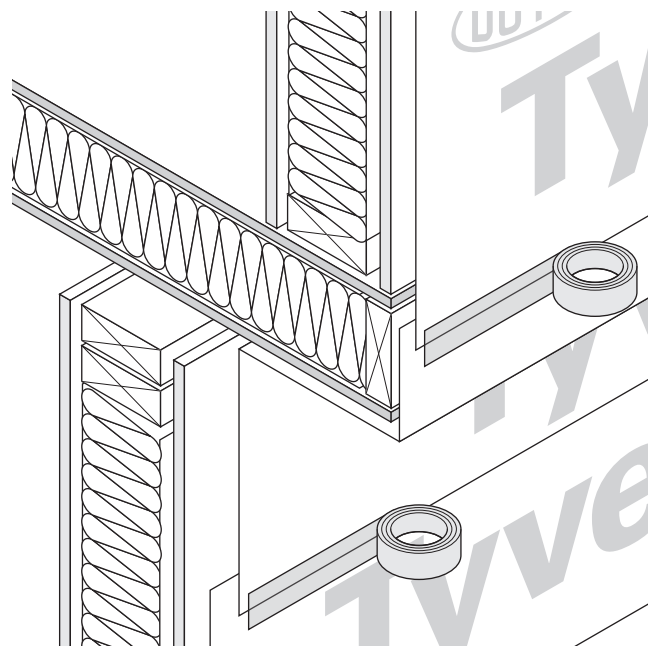

Roof-Wall Interface

Lap DuPont™ Tyvek® over all flashing at roof-wall interfaces and tape DuPont™ Tyvek® to the flashing.

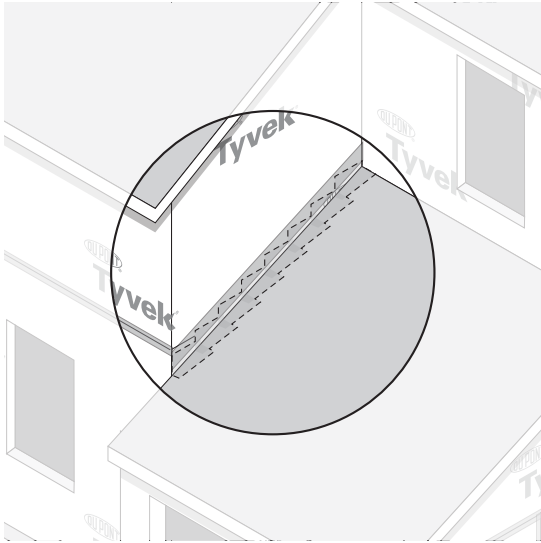

Lap DuPont™ Tyvek® over all flashing (e.g. wall to roof intersections and thru-wall flashings).

Penetrations

There are many types of penetrations including dryer vents, bathroom exhaust fans, exterior electrical outlets, exterior lights, gas lines, etc.

Seal the DuPont™ Tyvek® around all electrical, HVAC and plumbing penetrations with sealant or approved sheathing tape, or DuPont™ Flashing Systems products.

Start taping or flashing at bottom of penetrations, shingling upper tape over bottom tape.

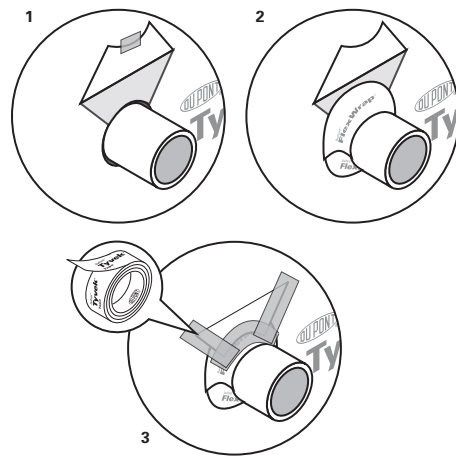

Products that have flanges should be integrated into the air barrier using approved sheathing tape, or DuPont™ Flashing Systems products.

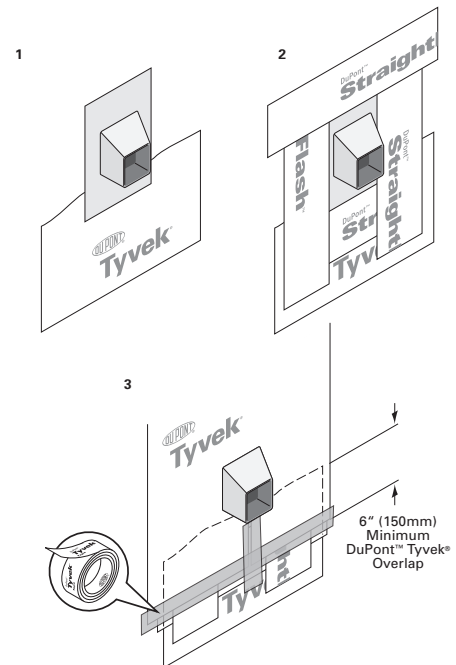

Handling Tears and Holes

During the course of installing the air barrier, minor tears may occur. Be sure to tape all tears. Tears can easily be covered with approved sheathing tape or DuPont™ Flashing Systems products.

Larger holes (greater than 1" (25 mm)) may require you to cut a piece of DuPont™ Tyvek® air barrier to cover the hole. Keep in mind shingling.

Make a cut 2" (50 mm) above the hole and extending a minimum of 2" (50 mm) on each side of the hole. Measure and cut a piece of DuPont™ Tyvek®. Tuck the cut piece of DuPont™ Tyvek® underneath the tear. Tape along the perimeter by starting at bottom of tear, shingling upper tape over bottom tape.

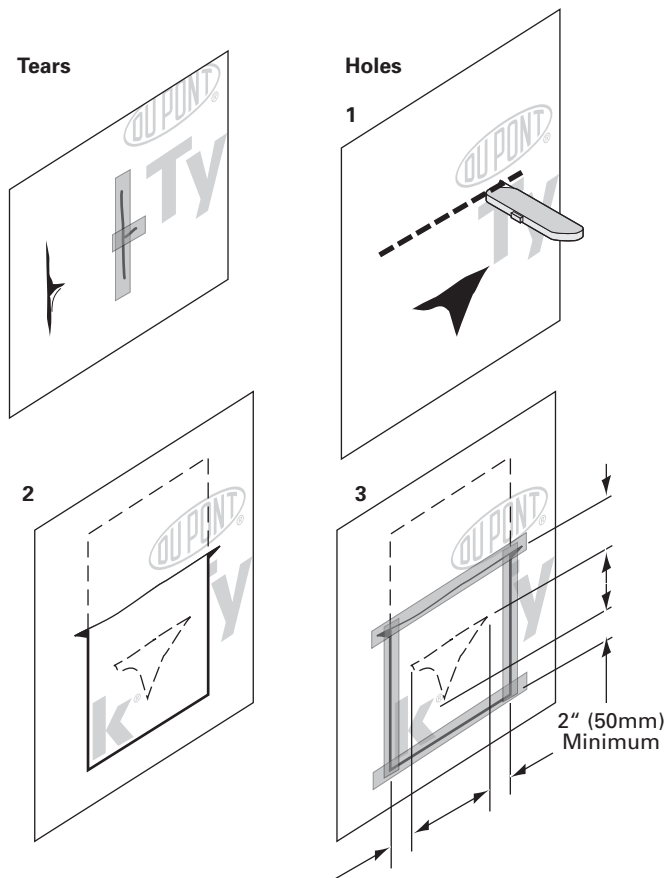

DuPont™ Flashing Systems Integration

If windows and doors have not been installed reference the DuPont™ Flashing Systems Installation Guidelines to prepare the rough opening.

If windows and doors are already flashed, then follow these last 2 integration steps to tie the air barrier into the flashing.

STEP 1

- A. Verify that the air barrier is properly shingled with the bottom of the apron.
- B. Cut as shown to expose window and apron. **DO NOT CUT THROUGH DUPONT™ FLEXWRAP™ OR APRON.**

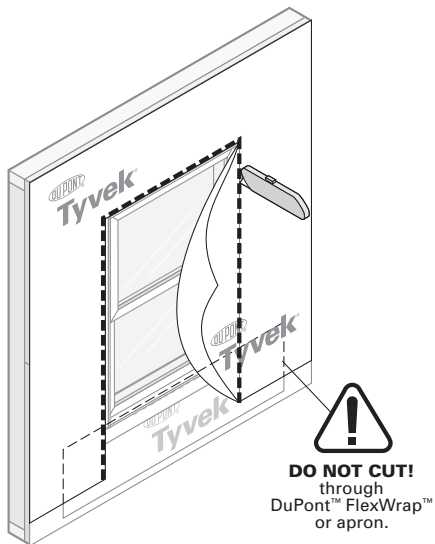

STEP 2

- A. Tape all seams as shown. **DO NOT TAPE** at bottom of window.

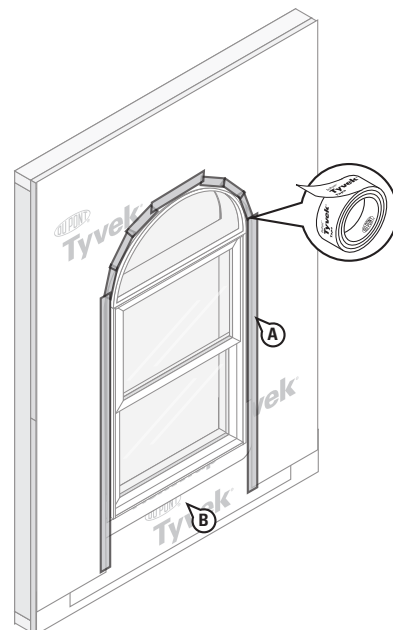
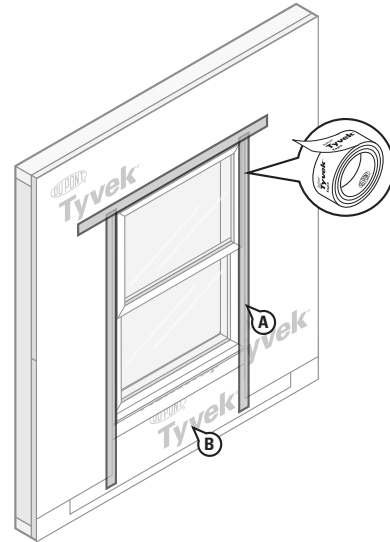

Technical Specifications

DuPont™ Tyvek® air barriers used in construction products is made from 100% flash spunbonded high density polyethylene fibers which have been bonded together by heat and pressure, without binders or fillers, into a tough, durable sheet structure. Additives have been incorporated into the polyethylene to provide ultraviolet light resistance. DuPont requires that DuPont™ Tyvek® air barriers be covered within four months (120 days) of installation.

DuPont™ Flashing Systems products are made from a synthetic rubber adhesive and a laminate of polyethylene film, elastic fiber, synthetic rubber adhesive, polyurethane adhesive, and a top sheet of flash spunbonded high density polyethylene fibers. Additives have been incorporated into these materials to provide ultraviolet light resistance. DuPont requires that DuPont™ Tyvek® HomeWrap®, DuPont™ Tyvek® and DuPont™ Tyvek® HeaderWrap® be covered within 4 months (120 days) of its installation. DuPont™ Tyvek® CommercialWrap® must be covered within 9 months (270 days) of its installation.

Warning

DuPont™ Tyvek® air barriers are slippery and should not be used in any application where it will be walked on. In addition, because it is slippery, DuPont recommends using kickjacks or scaffolding for exterior work above the first floor. If ladders must be used, extra caution must be taken to use them safely by following the requirements set forth in CAN3-Z11-M81 (R2005) for portable ladders. DuPont™ Tyvek® is combustible and should be protected from a flame and other high heat sources. DuPont™ Tyvek® will melt at 275°F (135°C) and if the temperature of DuPont™ Tyvek® reaches 750°F (400°C), it will burn and the fire may spread and fall away from the point of ignition. For more information, call 1-800-44-Tyvek.

DuPont™ Flashing Systems products and their release paper are slippery and should not be walked on. Remove release paper from work area immediately. DuPont™ Flashing Systems products will melt at temperatures greater than 250°F (121°C). DuPont™ Flashing Systems products are combustible and should be protected from flame and other high heat sources. DuPont™ Flashing Systems products will not support combustion if the heat source is removed. However, if burning occurs, ignited droplets may fall away from the point of ignition. For more information, call 1-800-44-Tyvek.

Note

When installed in conjunction with other building materials, DuPont™ Flashing Systems must be properly shingled with these materials, such that water is diverted to the exterior of the wall system. DuPont™ Tyvek® products are secondary weather barriers, not the primary water barrier. The outer façade is the primary barrier. You must follow façade manufacturer's installation and maintenance requirements for all façade systems in order to maintain water holdout properties and ensure performance of DuPont™ Tyvek®. Use of additives, coatings or cleansers on or in the façade system may impact the performance of DuPont™ Tyvek® water-resistive barriers. DuPont™ Tyvek® Weather Barrier Systems products are to be used as outlined in this installation guideline. DuPont™ Flashing Systems products are not suggested for use on roof windows. For superior protection against bulk water penetration, DuPont suggests a system combining a quality exterior façade, a good secondary weather barrier and an exterior sheathing, appropriate flashing materials and details; and high quality windows and doors with particular attention to proper installation of each component. In a system where no exterior sheathing is used and DuPont™ Tyvek® is installed directly over the wall studs, exterior façade materials should be selected to ensure maximum protection against water intrusion. Careful workmanship and proper installation of each component is very important.

DuPont believes this information to be reliable and accurate. The information may be subject to revision as additional experience and knowledge is gained. It is the user's responsibility to determine the proper construction materials needed.

For complete warranty information please see the full Warranty at www.Construction.Tyvek.com. To submit a warranty claim, please contact DuPont at www.Construction.Tyvek.com or call 1-800-44-Tyvek. Warranty coverage requires submission of proof of purchase of the DuPont™ Tyvek® at issue.

This information is not intended to be used by others for advertising, promotion or other publication for commercial purposes.

For more information about DuPont™
Tyvek® Weatherization Systems,
please call 1-800-44-Tyvek or visit us at
www.Construction.Tyvek.com



The miracles of science™

DuPont™
Tyvek®