

# Ventilation System Effectiveness and Tested Indoor Air Quality Impacts

Building America Report - 1309

March 2013

Armin Rudd and Daniel Bergey

---

Abstract:

*Airtightness of new homes is critical to achieving low-energy consumption, healthy and comfortable spaces, and durability. Airtight homes require rational and predictable ventilation. A key gap and area of ongoing research is to allow credit for better performing ventilation systems, such as supply and balanced ventilation compared to exhaust, and systems with predictable filtration of outside air and recirculation filtration. This would yield energy savings and reduced moisture control risk in humid climates, without compromising indoor air quality relative to the least performing system allowed by ASHRAE Standard 62.2. Building on previous research dealing with ventilation air distribution, this study added new elements of ventilation effectiveness research, accounting for source of outside air, particle contaminants, and VOC contaminants. These new data give further support for ventilation rate credit for better performing ventilation systems. The intended result is to provide specific guidance for understanding whole-building ventilation system effectiveness, which is critical to promoting the best low energy and high value ventilation solutions.*

---

# Ventilation System Effectiveness and Tested Indoor Air Quality Impacts

Armin Rudd, Daniel Bergey

March 2013

## NOTICE

This report was prepared as an account of work sponsored by an agency of the United States government. Neither the United States government nor any agency thereof, nor any of their employees, subcontractors, or affiliated partners makes any warranty, express or implied, or assumes any legal liability or responsibility for the accuracy, completeness, or usefulness of any information, apparatus, product, or process disclosed, or represents that its use would not infringe privately owned rights. Reference herein to any specific commercial product, process, or service by trade name, trademark, manufacturer, or otherwise does not necessarily constitute or imply its endorsement, recommendation, or favoring by the United States government or any agency thereof. The views and opinions of authors expressed herein do not necessarily state or reflect those of the United States government or any agency thereof.

Available electronically at <http://www.osti.gov/bridge>

Available for a processing fee to U.S. Department of Energy  
and its contractors, in paper, from:

U.S. Department of Energy  
Office of Scientific and Technical Information  
P.O. Box 62  
Oak Ridge, TN 37831-0062  
phone: 865.576.8401  
fax: 865.576.5728

email: <mailto:reports@adonis.osti.gov>

Available for sale to the public, in paper, from:

U.S. Department of Commerce  
National Technical Information Service  
5285 Port Royal Road  
Springfield, VA 22161  
phone: 800.553.6847  
fax: 703.605.6900

email: [orders@ntis.fedworld.gov](mailto:orders@ntis.fedworld.gov)

online ordering: <http://www.ntis.gov/ordering.htm>



## **Task Order 3**

### **Task 7: Evaluation and Testing of Individual Retrofit Measures**

#### **Deliverable 7.5.3 – 7.5 Ventilation System Effectiveness and Distribution: Draft Technical Report**

Prepared for:

The National Renewable Energy Laboratory

On behalf of the U.S. Department of Energy's Building America Program

Office of Energy Efficiency and Renewable Energy

15013 Denver West Parkway

Golden, CO 80401

NREL Contract No. DE-AC36-08GO28308

Prepared by:

Armin Rudd and Daniel Bergey

Building Science Corporation

30 Forest Street

Somerville, MA 02143

NREL Technical Monitor: Cheryn Engebrecht

Prepared under Subcontract No. KNDJ-0-40337-00

March 2013

**[This page left blank]**

# Contents

List of Figures .....	vii
List of Tables .....	ix
Definitions.....	x
Executive Summary .....	xii
<b>1 Problem Statement.....</b>	<b>1</b>
1.1 Introduction.....	1
1.2 Background.....	1
1.2.1 Relevant Issues with ASHRAE Standard 62.2 .....	2
1.2.2 Research Questions.....	5
1.3 Relevance to Building America’s Goals.....	6
1.4 Cost-Effectiveness .....	6
1.5 Tradeoffs and Other Benefits.....	9
<b>2 Previous Research .....</b>	<b>10</b>
<b>3 Test and Analysis Method .....</b>	<b>10</b>
3.1 Description of the Test Houses.....	10
3.2 HVAC System Modifications and Pre-Testing.....	13
3.3 Testing Approach.....	16
3.3.1 Baseline Test.....	17
3.3.2 Exhaust Test.....	17
3.3.3 Exhaust With Mixing Test.....	17
3.3.4 Central-Fan-Integrated Supply Test.....	18
3.3.5 Energy Recovery Ventilator Test.....	18
3.4 Building Enclosure, Central Air Distribution System, and Ventilation Systems Characterization .....	21
3.5 PerFluorocarbon (PFT) Tracer Gas testing.....	21
3.6 Airborne Particulate Sampling.....	24
3.7 Volatile Organic Compound Sampling.....	26
3.8 Formaldehyde Sampling.....	27
<b>4 Discussion of Results .....</b>	<b>28</b>
4.1 Building Air Leakage Characterization .....	28
4.1.1 Fan Pressurization Tests .....	28
4.2 HVAC Characterization.....	29
4.3 PerFluorocarbon (PFT) Tracer Gas testing.....	31
4.3.1 Zone Air Change Rates.....	31
4.3.2 Inter-zonal Airflows.....	35
4.4 Airborne Particulate Sampling.....	44
4.5 Formaldehyde Sampling.....	54
4.6 Volatile Organic Compound Sampling.....	57
<b>5 Impact for Building America Ventilation Rates .....</b>	<b>68</b>
<b>6 Conclusions and Recommendations .....</b>	<b>70</b>
Acknowledgements .....	73
References.....	73
<b>Appendix A. Listing of all Top 20 Volatile Organic Compounds Found, and their Functional     Descriptions .....</b>	<b>76</b>
<b>Appendix B. Preliminary CONTAM Model .....</b>	<b>79</b>
B.1 Building and Zonal Leakage Characterization by Fan Pressurization Testing .....	79
B.2 Leakage Inputs for CONTAM Modeling.....	82

B.3 Future Model Refinement .....84

## List of Figures

Figure 1. Calculations showing that ASHRAE Standard 62.2-2010 addenda 'r' ventilation fan airflow rates are about 40% higher than before addenda 'r', averaged over a range of climates, building archetypes, and building air tightness.....	2
Figure 2. Energy Savings and Costs: Vented Attic, 5% Duct Leakage .....	8
Figure 3: Energy Savings and Costs: Vented Attic, No Duct Leakage.....	9
Figure 4: Energy Savings and Costs: Unvented Attic, No Duct Leakage .....	9
Figure 5. Location and directions to the test homes at University of Texas-Tyler .....	11
Figure 6. House 1 vented attic (left) and House 2 unvented attic (right).....	12
Figure 7. Exterior photos of the test homes at the University of Texas-Tyler; House 1 has the darker roof.....	12
Figure 8. Energy Recovery Ventilator installed in House 1 to match that of House 2.....	13
Figure 9. Wye'd outside air duct, airflow stations, and inline fan for retrofitting a CFIS ventilation system in each attic (left); setting the CFIS airflow rate with Iris damper airflow station (top); fan timer and relay arrangement (bottom) .....	14
Figure 10. Test house floor plan.....	15
Figure 11. House 1 temperature and relative humidity in indoor zones and outdoors during each test period .....	19
Figure 12. House 2 temperature and relative humidity in indoor zones and outdoors during each test period .....	20
Figure 13. Wind speed during each of the test periods; green and red markers indicate start and stop of the 12-hour sampling periods .....	21
Figure 14. House 2 Main zone with PFT source tripod on left and sampling station tripod on right.....	23
Figure 15. PFT source (left) and primary and backup CATS (right) .....	24
Figure 16. Cumulative particle counts for six particle sizes during the Baseline test in House 2, Main zone; results show impact on large particle counts due to human disturbance 1.5 hour before end of sampling period.....	25
Figure 17. Test fixture tripod holding (left to right in photos) formaldehyde sample pump, temperature and relative humidity datalogger, PFT sample tubes (CATS), airborne particulate counter, and VOC sampling pump.....	26
Figure 18. VOC sampling pump and solid sorbent sample tube; airborne particulate counter on top of sampling fixture.....	27
Figure 19. Air change rates in the living space zones for House 1 (vented attic), for the Baseline test and four different ventilation systems .....	32
Figure 20. Measured air change rates in the Garage and Attic zones for House 1, for different ventilation systems .....	33
Figure 21. Air change rates in the living space zones for House 2 (unvented attic), for the Baseline test and four different ventilation systems, showing the same trends as House 1 .....	34
Figure 22. Measured air change rates in the Garage and Attic zones for House 2, for the Baseline test and four different ventilation systems .....	35
Figure 23. Airflow from Garage to living area zones in House 1, for the Baseline test and four different ventilation systems.....	36
Figure 24. Airflow from Garage to living area zones in House 2, for the Baseline test and four different ventilation systems, showing the same trends as House 1 .....	37
Figure 25. Airflow from Attic to living area zones in House 1, for the Baseline test and four different ventilation systems.....	38
Figure 26. Airflow from Attic to living area zones in House 2, for the Baseline test and four different ventilation systems.....	39
Figure 27. Backup CATS analyzed for QA/QC check; House 2, Test 2 (Exhaust).....	40
Figure 28. House 1 interzonal airflows for living space zones.....	41
Figure 29. House 1 reverse direction interzonal airflows for living space zones .....	42
Figure 30. House 2 interzonal airflows for living space zones.....	43
Figure 31. House 2 reverse direction interzonal airflows for living space zones .....	44
Figure 32. Cumulative particle counts for six particle sizes (0.3-10 micrometer) for the House 1	



Main and Master zones .....	47
Figure 33. Cumulative particle counts for six particle sizes (0.3-10 micrometer) for the House 2 Main and Master zones .....	49
Figure 34. Cumulative particle counts for six particle sizes (0.3-10 micrometer) for the Attic and Garage zones for House 1 and House 2.....	52
Figure 35. Cumulative particle counts for six particle sizes (0.3-10 micrometer) sampled outside on the first and last test days (test day 1 and test day 6) .....	53
Figure 36. Cumulative particle counts for six particle sizes (0.3-10.0 micron) for simultaneous measurements made outside and inside during the H2 Baseline test .....	54
Figure 37. Formaldehyde concentration measured in the Main and Master zones of House 1 and House 2 during the Baseline test and four ventilation system tests .....	56
Figure 38. Attic and garage formaldehyde concentrations for both houses.....	56
Figure 39. Concentrations of the Top 11 volatile organic compounds found in the Main zone of House 1, for the Baseline test and four different ventilation systems.....	58
Figure 40. Concentrations of the Top 11 volatile organic compounds found in the Master zone of House 1, for the Baseline test and four different ventilation systems.....	59
Figure 41. Concentrations of the Top 10 volatile organic compounds found in the Main zone of House 2, for the Baseline test and four different ventilation systems.....	60
Figure 42. Concentrations of the Top 10 volatile organic compounds found in House 2 Master zone, for the Baseline test and four different ventilation systems .....	61
Figure 43. VOCs found in the attics of House 1 and House 2 .....	65
Figure 44. VOCs found in the garages of House 1 and House 2.....	67
Figure B- 1. CONTAM Model of House 1.....	84
Figure B- 2. CONTAM Model of House 2.....	84

## List of Tables

Table 1. BeOpt simulations of the UT-Tyler houses with unvented attic and vented attic, showing energy consumption by end-use for different ventilation systems and ventilation airflow rates	8
Table 2. Test number, name, and description of the five tests conducted in each house	17
Table 3. Type and number of tracer gas sources used in each house and test	22
Table 4. Physical characteristics of the test houses	29
Table 5. Typically reported blower door test results for each test house	29
Table 6. Duct Leakage Tests	30
Table 7. Central air distribution system (heat pump) cooling supply airflows	30
Table 8. Ventilation system airflow and runtime setup	31
Table 9. Calculation of differential particle counts over the range of 0.3-2.0 micron; the percent difference in differential counts are shown compared to the Exhaust ventilation system	50
Table 10. Cumulative and differential particle counts measured outdoors during baseline tests on the first and last test days	51
Table 11. Formaldehyde concentrations in House 1 and House 2, for the Baseline test and four different ventilation systems	55
Table 12. Total Volatile Compounds (TVOC) by House, zone, and ventilation system	62
Table 13. TVOC measurements in the Attic and Garage zones of both houses	63
Table 14. VOCs found in both attics, sorted by high to low concentration in the House 2 unvented attic	64
Table 15. VOCs found in both garages, sorted by highest to lowest in the House 1 garage	66
Table 16. Recommended System Factors to reduce ventilation fan airflow rates relative to ASHRAE Standard 62.2-2010 addendum r	69
Table 17. Numerical basis for the System Factors shown in Table 16, given as percent airflow rate reduction for each System Factor Category	69
Detailed whole-building and zonal leakage fan pressurization test results, including those from numerous guarded tests are given in	79
Table B- 1. House 1 Guarded and Unguarded Fan Pressurization Test Results	80
Table B- 2 House 2 (unvented attic) Guarded and Unguarded Fan Pressurization Test Results	81
Table B- 3. House 1 CONTAM Model Inputs	82
Table B- 4. House 2 CONTAM Model Inputs	83

## Definitions

ach	air changes per hour
ach50	air changes per hour at 50 Pascal pressure differential
AHAM	Association of Home Appliance Manufacturers
AHRI	Air Conditioning Heating and Refrigeration Institute
AHU	Air handler unit
ASHRAE	American Society of Heating, Refrigerating and Air-Conditioning Engineers
ASTM	American Society for Testing And Materials
BA	Building America Program. More information about BA can be found at <a href="http://www.buildingamerica.gov">www.buildingamerica.gov</a>
BeOpt	Building Energy Optimization Program – House energy simulation program and primary analysis tool for Building America homes.
BNL	Brookhaven National Laboratory
BSC	Building Science Corporation. More information about BSC can be found at <a href="http://www.buildingscience.com">www.buildingscience.com</a>
CFIS	Central-fan-integrated supply ventilation
CFM 50	Cubic feet per minute at 50 Pascal test pressure differential
CONTAM	Contaminant transport computer program
DOE	U.S. Department of Energy
ELA	Effective Leakage Area
EqLA	Equivalent Leakage Area
EPA	U.S. Environmental Protection Agency
ERV	Energy recovery ventilator
HRV	Heat recovery ventilator
HUD	U.S. Department of Housing and Urban Development

ICC	International Code Council
IECC	International Energy Conservation Code. More information can be found at <a href="http://www.energycodes.gov/">http://www.energycodes.gov/</a>
IMC	International Mechanical Code
IRC	International Residential Code
MBC	Minnesota Building Code
MERV	Minimum Efficiency Rating Value
MPR	Micro-particle Performance Rating
NRC	Natural Resources Canada
NBC	National Building Code of Canada
NREL	National Renewable Energy Laboratory
OSHA	Occupational Safety and Health Administration
Pa	Pascal; SI unit of pressure (equivalent to one newton per square meter)
PFT	Passive Fluorocarbon Tracer
RH	relative humidity
UL-AQS	Underwriters Laboratory - Air Quality Sciences Division
WAVIAQ	Washington State Ventilation and Indoor Air Quality Code

## Executive Summary

Airtightness of new homes is critical to achieving low-energy consumption, healthy and comfortable spaces, and durability. Airtight homes require rational and predictable ventilation. A key gap and area of ongoing research is to allow credit for better performing ventilation systems, such as supply and balanced ventilation compared to exhaust, and systems with predictable filtration of outside air and recirculation filtration. This would yield energy savings and reduced moisture control risk in humid climates, without compromising indoor air quality relative to the least performing system allowed by ASHRAE Standard 62.2. Building on previous research dealing with ventilation air distribution, this study added new elements of ventilation effectiveness research, accounting for source of outside air, particle contaminants, and VOC contaminants. These new data give further support for ventilation rate credit for better performing ventilation systems. The intended result is to provide specific guidance for understanding whole-building ventilation system effectiveness, which is critical to promoting the best low energy and high value ventilation solutions.

ASHRAE Standard 62.2-2010 may be considered to contain the “standard of care” for ventilation system design and operation in residential buildings, yet there are considerable technology gaps with that Standard. ASHRAE Standard 62.2 uses a catch-all approach that assumes that the entire house is a single, well-mixed zone and that there is no difference between different whole-building ventilation systems in providing effective ventilation. In other words, it does not differentiate between better and worse performing whole-building ventilation systems and the rates set are inferred to be adequate for the worst performing system. To try to facilitate that assumption, the ventilation rate has to be high enough to accommodate the worst performing system, which is single point exhaust.

The study focused on the in-situ impacts of various ventilation systems including the impacts of differing sources of outside air and the spatial distribution and filtration of ventilation air. The project involved testing two unoccupied, single-family, detached homes in Tyler, TX that were constructed as lab homes at the University of Texas – Tyler<sup>1</sup>. The twin lab homes at UT-Tyler offered a unique opportunity for the direct comparison of nearly identical homes except for one having a vented attic and the other having an unvented attic assembly (also known as sealed cathedralized attic).

Exhaust ventilation testing showed lower uniformity of outdoor air exchange rate between living space zones, and higher concentrations of particulates, formaldehyde and other Top 20 VOCs than did the supply and balanced ventilation systems. This showed that single-point exhaust ventilation was inferior as a whole-house ventilation strategy. It was inferior because the source of outside air was not directly from outside (much of it came from the attic), the ventilation air was not distributed, and no provision existed for air filtration. Indoor air recirculation by a central air distribution system can help improve the exhaust ventilation system by way of air mixing and filtration. In contrast, the supply and balanced ventilation systems showed that there is a significant benefit to drawing outside air from a known outside location, and filtering and fully distributing that air.

---

<sup>1</sup> Learn more at [www.UT-Tyler.edu/TxAIRE/Technology/Houses](http://www.UT-Tyler.edu/TxAIRE/Technology/Houses)

The central-fan-integrated supply (CFIS) ventilation system showed an 85% and 73% reduction in 0.3-2.0 micron particles for House 1 and House 2, respectively, attributable to recirculation air filtration by operation of the central air distribution system.

Total Volatile Compound (TVOC) data showed that, compared to the Exhaust system, the CFIS and ERV ventilation systems reduced TVOC by 47% and 57%, respectively, averaged between the two houses. Compared to the Baseline tests, the Exhaust system increased TVOC by 37% in the House 1 Main zone, and increased TVOC by 18% in the House 2 Master zone. This highlights that the unknown air path, or source of outside air, for the Exhaust ventilation system can cause indoor air to be more contaminated depending on what contaminants are picked up on the way in.

Ventilation System Factors developed in this study could be applied to allow accounting for ventilation system attributes that improve the system's performance. While analysis did not quantify the collective effect of reduced contaminant exposure to occupants, engineering judgment can be applied based on the quantitative results of the individual factors. Engineering judgment is valid here since the ASHRAE Standard 62.2 ventilation rates are themselves based only on the engineering judgment and experience of the committee members, not on any health or medical studies. Values for percent reductions in ventilation airflow were assigned for each system improvement that exists for a given ventilation system. These values were then summed to give a total percent reduction. The individual system improvements were based on four System Factor Categories: Balance, Distribution, OA Source, and Recirculation Filtration. Application of the System Factors is recommended for consideration in the DOE Building America and Challenge Home programs to allow credit for better performing ventilation systems. This would yield energy savings and reduced moisture control risk in humid climates, without compromising indoor air quality relative to the worst performing system allowed by ASHRAE Standard 62.2-2010. Such ventilation rate credits would also benefit the EPA Indoor Air program required by the DOE Challenge Home.

# 1 Problem Statement

## 1.1 Introduction

This study focuses on the in-situ impacts of various ventilation systems including the impacts of differing sources of outside air and the spatial distribution and filtration of ventilation air. The project involved testing two unoccupied, single-family, detached homes in Tyler, TX that were constructed as lab homes at the University of Texas – Tyler<sup>2</sup>. The twin lab homes at UT-Tyler offered a unique opportunity for the direct comparison of nearly identical homes except for one having a vented attic and the other having an unvented attic assembly (also known as sealed cathedralized attic).

## 1.2 Background

The residential building sector consumes approximately 21% of the primary energy used in the United States (DOE/EIA 2008). Energy consumption due to ventilation needs is increasingly becoming a high percentage of total space conditioning energy consumption. Accounting for better performing ventilation systems is a reasonable step in the effort to reduce energy consumption without compromising indoor air quality, comfort, or durability.

Airtightness of new homes is critical to achieving low-energy consumption, healthy spaces, and durability. Airtight homes require rational and predictable ventilation. A key gap and area of ongoing research is enabling a reduction of ventilation airflow relative to ASHRAE Standard 62.2-2010 addendum ‘r’ (having about 40% higher airflow requirement relative to before addendum r; see Figure 1) to reduce energy consumption, improve humidity control performance, and improve indoor air quality over a time scale less than annual average. Identifying methods to achieve such reductions would benefit the EPA Indoor Air program required by the DOE Challenge Home. Research should be conducted into methods that include considerations for:

- Accounting for the quality of the source of outside air for different ventilation systems types.
- Accounting for ventilation air distribution effectiveness.
- Managing hazardous indoor air pollutants in ways other than air change.

---

<sup>2</sup> Learn more at [www.UT-Tyler.edu/TxAIRE/Technology/Houses](http://www.UT-Tyler.edu/TxAIRE/Technology/Houses)

CLIMATE ZONE	LOCATION	ASHRAE WSF*	2-story, 62.2-2010 fan cfm=54				1-story, 62.2-2010 fan cfm=50			
			3.0 ach50		1.5 ach50		3.0 ach50		1.5 ach50	
			62.2 'r' fan cfm	% diff from 62.2	62.2 'r' fan cfm	% diff from 62.2	62.2 'r' fan cfm	% diff from 62.2	62.2 'r' fan cfm	% diff from 62.2
Warm-Humid Zone	Orlando, FL	0.39	73	35%	88	62%	71	42%	81	61%
Warm-Humid Zone	Houston, TX	0.40	72	34%	87	61%	71	41%	80	61%
Warm-Humid Zone	Charleston, SC	0.43	70	30%	86	59%	69	38%	80	59%
Mixed-Humid Zone	Baltimore, MD	0.50	65	20%	83	55%	66	31%	78	56%
Mixed-Humid Zone	Kansas City, MO	0.60	58	7%	80	48%	61	22%	75	51%
Mixed-Humid Zone	Charlotte, NC	0.43	70	30%	86	59%	69	38%	80	59%
Cold-Humid Zone	Minneapolis, MN	0.63	55	2%	79	46%	59	19%	75	49%
Cold-Humid Zone	Chicago, IL	0.60	58	7%	80	48%	61	22%	75	51%
Dry Zone	Phoenix, AZ	0.43	70	30%	86	59%	69	38%	80	59%
Dry Zone	Denver, CO	0.61	57	5%	79	47%	60	21%	75	50%
Marine Zone	Los Angeles, CA	0.42	71	31%	86	60%	70	39%	80	60%
Marine Zone	Seattle, WA	0.56	61	12%	81	50%	63	26%	76	53%
average of climates:			65	20%	83	55%	66	31%	78	56%
			62.2 'r' fan cfm	% diff from 62.2						
average of climate, archetype, and tightness:			73	40%						

\* ASHRAE 62.2 Weather and Shielding Factor per ASHRAE 62.2 addenda 'n' & 'r'

**Figure 1. Calculations showing that ASHRAE Standard 62.2-2010 addenda 'r' ventilation fan airflow rates are about 40% higher than before addenda 'r', averaged over a range of climates, building archetypes, and building air tightness**

**1.2.1 Relevant Issues with ASHRAE Standard 62.2**

ASHRAE Standard 62.2-2010 may be considered to currently contain the “standard of care” for ventilation system design and operation in residential buildings, yet there are considerable technology gaps with that Standard. ASHRAE Standard 62.2 uses a catch-all approach that assumes that the entire house is a single, well-mixed zone and that there is no difference between different whole-building ventilation systems in providing effective ventilation. To try to facilitate that assumption, the ventilation rate has to be high enough to accommodate the worst performing system, which is single point exhaust. Utilizing high performing systems that draw outside air from a known fresh air location and filter and fully distribute that air to the occupants breathing zone (including bedrooms where occupants spend the most continuous time) should allow optimization of the ventilation rate to avoid the energy consumption and moisture control problems of over-ventilation.

The ventilation rates in ASHRAE Standard 62.2 are currently based entirely on the collective engineering judgment of the committee members. They are based on committee member’s notions of what they feel good about based on their own experience and judgment in view of information they are currently aware of. There is no published basis for the rates in any health or



medical study. Using engineering judgment based on new information, such as in this study, to make adjustments to numbers that are themselves based on engineering judgment is appropriate.

In accounting for intermittent versus continuous ventilation, ASHRAE Standard 62.2 uses relative annual average dose to a generic contaminant as the only metric to allow for a performance-based compliance approach and to account for intermittent versus continuous ventilation. That metric may be valid for avoiding exposure to contaminants that may cause cancer over 20 years, but that metric completely ignores shorter term odor, moisture, and sensory irritation effects which is really the only obvious metric occupants have available to determine their satisfaction level with indoor air. While the available medical science for cancer causing chemical contaminants at concentrations typically found in residential environments is almost non-existent, the science for shorter term asthma and allergy response is better known (Carl-Gustaf Bornehag et al. 2004). Occupant observation of objectionable odor, visible moisture or mold caused by that moisture, and sensory irritation is overt. Those overt objections are what home builders have to deal with even though ASHRAE Standard 62.2 primarily does not.

#### *Source of Outside Air*

ASHRAE Standard 62.2-2010 requires that supply and balanced ventilation systems draw outside air directly from a known fresh air location but does not include any such requirement for exhaust ventilation systems. Therefore make up air for exhaust ventilation air comes from the paths of least resistance, which could be through a garage, attic, crawlspace, basement, or other soil contact location. To be consistent, at the very least the Standard would need to require intentional makeup air inlets, or, much better, require a supply system that provides makeup air from a known fresh air location whenever the whole-building exhaust ventilation system was operating.

In contrast, the following building codes have provisions requiring direct outside air for all ventilation systems: the International Mechanical Code, the Washington State Ventilation and Indoor Air Quality Code, the U. S. Housing and Urban Development Code, and the National Building Code of Canada. A brief description of those requirements follows:

**IMC 2012:** The IMC 2012 requires a balanced ventilation system with outdoor supply air approximately equal to exhaust air.

**WAVIAQ Code 2009:** The WAVIAQ Code 2009 requires that ventilation systems must have direct outdoor air inlets, and that they be screened and located so as not to take air from a list of contaminated areas, including areas where odors may be objectionable, attics, crawlspaces, or garages.

**HUD Code 2008:** The HUD Code requires that the ventilation system be balanced, and designed to exchange air directly with the exterior of the home. It specifically prohibits air drawn from the space underneath the home, through the floor, walls, or ceiling/roof systems.

**NBC 2005:** The NBC 2005 stipulates that outside air supply be provided and connected directly to outside.

#### *Ventilation Effectiveness*

In terms of ventilation effectiveness, ASHRAE Standard 62.2 accounts only for temporal (time based) effectiveness over an annual average; there is no provision for spatial (space-to-space) ventilation distribution effectiveness, or system effects. In other words, ASHRAE Standard 62.2 accounts for ventilation effectiveness only in regards to system runtime. Even so, while the maximum ventilation air delivery cycle time is truncated to one day, the runtime effectiveness values are based on calculations that would allow the ventilation system to be off for months without any decrease in effectiveness, because the evaluation metric is locked to relative annual average exposure to a generic contaminant<sup>3</sup>. That approach ignores shorter term indoor air quality effects of odor and sensory irritation, which are nevertheless stated parts of an acceptable indoor air quality approach in the ASHRAE Standard 62.2 Scope, and definitions of “acceptable indoor air quality” and “air cleaning.”

In contrast, the following building codes have provisions requiring ventilation air distribution for all ventilation systems: International Mechanical Code, Minnesota Building Code, Washington State Ventilation and Indoor Air Quality Code, the U. S. Housing and Urban Development Code, and the National Building Code of Canada. A brief description of those requirements follows:

**IMC 2012:** The IMC requires an approximately balanced ventilation system with the ventilation supply system designed to deliver the required rate of outdoor airflow to the breathing zone within each occupiable space. The WAVIAQ Code requires the introduction and distribution of outdoor air and the removal of indoor air by mechanical means. It further requires that outdoor air be distributed to each habitable room by means such as individual inlets, separate duct systems, or a forced-air system.

**MBC 2009:** The MBC requires ventilation air distribution and circulation such that outdoor air is delivered to each habitable space by a forced air circulation system, separate duct system, individual inlets, or a passive opening. When outside air is directly ducted to a forced air circulation system, circulation of 0.075 cfm/ft<sup>2</sup> must be maintained on average each hour. When outside air is not directly ducted to a forced air circulation system, circulation of 0.15 cfm/ft<sup>2</sup> must be maintained on average each hour.

**WAVIAQ Code 2009:** The WAVIAQ Code requires the introduction and distribution of outdoor air and the removal of indoor air by mechanical means. It further requires that outdoor air be distributed to each habitable room by means such as individual inlets, separate duct systems, or a forced-air system. Conflictingly, in homes with exhaust only ventilation systems without outdoor air inlets the home must have a ducted forced air heating system that communicates with all habitable rooms and the interior doors must be undercut to a minimum of ½- inch above the surface of the finish floor covering; however, nothing is mentioned about a minimum interval of ducted forced air heating system communication with all habitable spaces. This will typically leave days and weeks on end with minimal ventilation air distribution.

---

<sup>3</sup> Relative annual average dose is the only metric used in ASHRAE Standard 62.2 for the performance based compliance method and to calculate intermittent ventilation effectiveness factors. The method tracks a generic contaminant (rather than any specific contaminants) and compares the annual average dose of the generic contaminant (in an assumed single-zone, well-mixed building model) using an actual continuous or intermittent ventilation air exchange rate relative to a reference continuous air exchange rate.

**HUD Code 2008:** The HUD Code requires that ventilation system be designed to ensure that outside air is distributed to all bedrooms and main living areas.

**NBC 2005:** In the NBC, for ventilation systems not used in conjunction with a forced air heating system, an outside air supply ventilation fan is required with the same rated capacity as the principle [exhaust] ventilation fan to distribute outside air directly to all bedrooms through a system of supply ducts. Where an exhaust-only system is installed via the principal ventilation fan, the exhaust fan control must be wired so that activation of the exhaust fan automatically activates the circulation fan of the forced air distribution system required at its rated capacity but not less than 5 times the rated capacity of the exhaust fan. Alternately, interlocking the forced air distribution system's circulation fan with the principal [exhaust] ventilation fan can be accomplished where the forced air distribution system is equipped with a control that automatically activates the circulation fan at user-selected intervals.

ASHRAE Standard 62.2 does not attempt to address the issue of delivery of outdoor airflow to each space, or to the breathing zone within each occupiable space, or forced air circulation/distribution of ventilation air. It simply makes an over-reaching assumption that for all ventilation system cases, the entire house is a single, well-mixed zone, focusing only on relative annual average exposure.

### **1.2.2 Research Questions**

The research presented in this report is intended to help develop a better understanding of whole-building ventilation system effectiveness and distribution in low energy homes which is critical to promoting the best low-energy and high-value ventilation solutions. BSC seeks to address the following research questions:

1. Do different whole-building ventilation systems perform significantly differently in terms of their ability to deliver uncontaminated ventilation air to the occupants?
2. What measurements and testing protocols are needed to appropriately account for the source of outside air relevant to occupant exposure to chemical and particulate contaminants and their expected satisfaction with indoor air in residential environments?
3. What is the overall indoor air quality impact of operating an exhaust whole-building ventilation system versus supply and balanced ventilation?
4. For whole-building ventilation systems that do not draw outside air directly from a known fresh air source, how much of the ventilation air is drawn through potentially contaminated adjacent spaces such as garages and vented attics?
5. What is the impact of drawing outdoor air through the building enclosure and adjacent unoccupied spaces on the level of particulate contaminants within the conditioned space?
6. What is the level of chemical contaminants within the conditioned space and adjacent spaces, and the impact of drawing outdoor air through the building enclosure and adjacent unoccupied spaces? What is the impact of drawing outdoor air through the building enclosure

and adjacent unoccupied spaces on the level of chemical contaminants within the conditioned space?

7. Does the testing and modeling conducted provide justification for lower ventilation rates for fully-distributed whole-building ventilation systems drawing outside air from a known fresh air location compared to lower performing systems?

### **1.3 Relevance to Building America's Goals**

Overall, the goal of the U.S. Department of Energy's (DOE) Building America program is to “reduce home energy use by 30%-50% (compared to 2009 energy codes for new homes and pre-retrofit energy use for existing homes).” To this end, we conduct research to “develop market-ready energy solutions that improve efficiency of new and existing homes in each U.S. climate zone, while increasing comfort, safety, and durability.”<sup>4</sup>

The combination of air-sealed building enclosures and controlled mechanical ventilation is an effective means to reduce energy consumption while providing improved indoor air quality and comfort in residential buildings. The results of this research project will further inform the residential building community on how effective different whole-building ventilation systems are in meeting these necessary goals. The results presented here provide new data on in-field performance of mechanical ventilations systems. They are intended to provide specific guidance for understanding whole-building ventilation system effectiveness, including the impacts of ventilation air distribution, the source of outside air, and particulate and VOC contaminant levels. This is critical to promoting the best low energy and high value ventilation solutions.

### **1.4 Cost-Effectiveness**

Ventilation energy consumption is a significant part of the energy consumption and energy cost of low energy homes. Understanding whole-building ventilation system performance in low energy homes is critical to promoting the highest value ventilation solutions for reducing energy consumption while providing good indoor air quality and comfort for the occupants. Over-ventilation unnecessarily consumes energy and raises the risk of comfort and indoor air quality problems due to elevated indoor humidity in warm-humid climates. Higher performing ventilation systems may be able to eliminate unnecessary over-ventilation, thereby providing equal or improved indoor air quality and comfort at lower cost.

The BEopt™ (Building Energy Optimization) software provides capabilities to evaluate residential building designs and identify cost-optimal efficiency packages at various levels of whole-house energy savings (Christensen 2006). Table 1 shows results from BeOpt simulations of the 1475 ft<sup>2</sup> UT-Tyler houses with an unvented attic and a vented attic. Energy consumption is listed by end-use for different ventilation systems, and for ventilation airflow rates equal to the ASHRAE Standard 62.2-2010 rate and 50% of that for systems that draw the outside air from a known fresh air location, filter, and fully distribute that ventilation air to the breathing zone of the occupants. Energy cost was calculated at a rate of \$0.103/kWh.

BeOpt simulations for the UT-Tyler Houses projected that ventilation accounts for 4% - 6% of total energy consumption, and that ventilation accounts for 12% - 22% of HVAC energy

---

<sup>4</sup> [http://www1.eere.energy.gov/buildings/building\\_america/program\\_goals.html](http://www1.eere.energy.gov/buildings/building_america/program_goals.html)

consumption. Reducing the ASHRAE 62.2-2010 ventilation rate by 50% (the basis for this is provided in section 5) was projected to reduce HVAC energy used for conditioning ventilation air by 8% to 10%, and was projected to reduce total energy consumption by 2% to 3%. With ASHRAE 62.2-2010 addendum 'r' ventilation rates being about 40% higher than before addendum 'r', if Energy Star and the DOE Challenge Home programs were to reference the addendum r rates, then the savings would be higher.

**Table 1. BeOpt simulations of the UT-Tyler houses with unvented attic and vented attic, showing energy consumption by end-use for different ventilation systems and ventilation airflow rates**

	Unvented attic, no duct losses					
	Source Energy Use (MBtu/yr)					
	1 - Exhaust 100% 62.2	2 - Supply 100% 62.2	3 - ERV 100% 62.2	4 - Supply 50% 62.2	5 - ERV 50% 62.2	6 - No Ventilation
Misc. (E)	37.56	37.56	37.56	37.56	37.56	37.56
Vent Fan (E)	1.66	1.66	4.97	0.96	2.62	0.25
Lg. Appl. (E)	20.25	20.25	20.25	20.25	20.25	20.25
Lights (E)	11.42	11.42	11.42	11.42	11.42	11.42
HVAC Fan/Pump (E)	2.81	2.84	2.79	2.69	2.72	2.61
Cooling (E)	16.73	16.79	16.61	16.07	16.18	15.53
Heating (E)	17.76	17.49	17.23	16.35	16.77	15.84
Hot Water (E)	26.05	26.05	26.05	26.05	26.05	26.05
<b>Total</b>	<b>134.25</b>	<b>134.06</b>	<b>136.89</b>	<b>131.36</b>	<b>133.57</b>	<b>129.52</b>
<b>Vent % Total</b>	<b>4%</b>	<b>4%</b>	<b>6%</b>	<b>1%</b>	<b>3%</b>	<b>0%</b>
<b>Diff 50% 62.2 vs 100% 62.2</b>				<b>2%</b>	<b>3%</b>	
<b>HVAC Subtotal</b>	<b>38.96</b>	<b>38.78</b>	<b>41.6</b>	<b>36.07</b>	<b>38.29</b>	<b>34.23</b>
<b>Vent % HVAC</b>	<b>14%</b>	<b>13%</b>	<b>22%</b>	<b>5%</b>	<b>12%</b>	<b>0%</b>
<b>Diff 50% 62.2 vs 100% 62.2</b>				<b>8%</b>	<b>10%</b>	

	Vented attic, 5% duct leakage					
	Source Energy Use (MBtu/yr)					
	1 - Exhaust 100% 62.2	2 - Supply 100% 62.2	3 - ERV 100% 62.2	4 - Supply 50% 62.2	5 - ERV 50% 62.2	6 - No Ventilation
Misc. (E)	37.56	37.56	37.56	37.56	37.56	37.56
Vent Fan (E)	1.66	1.66	4.97	0.96	2.62	0.25
Lg. Appl. (E)	20.25	20.25	20.25	20.25	20.25	20.25
Lights (E)	11.42	11.42	11.42	11.42	11.42	11.42
HVAC Fan/Pump (E)	3.34	3.48	3.27	3.2	3.21	3.08
Cooling (E)	18.47	18.8	18.46	17.98	18.04	17.41
Heating (E)	23.93	24.19	23.13	22.32	22.65	21.54
Hot Water (E)	26.05	26.05	26.05	26.05	26.05	26.05
<b>Total</b>	<b>142.69</b>	<b>143.41</b>	<b>145.12</b>	<b>139.75</b>	<b>141.81</b>	<b>137.56</b>
<b>Vent % Total</b>	<b>4%</b>	<b>4%</b>	<b>5%</b>	<b>2%</b>	<b>3%</b>	<b>0%</b>
<b>Diff 50% 62.2 vs 100% 62.2</b>				<b>3%</b>	<b>2%</b>	
<b>HVAC Subtotal</b>	<b>47.4</b>	<b>48.13</b>	<b>49.83</b>	<b>44.46</b>	<b>46.52</b>	<b>42.28</b>
<b>Vent % HVAC</b>	<b>12%</b>	<b>14%</b>	<b>18%</b>	<b>5%</b>	<b>10%</b>	<b>0%</b>
<b>Diff 50% 62.2 vs 100% 62.2</b>				<b>9%</b>	<b>8%</b>	

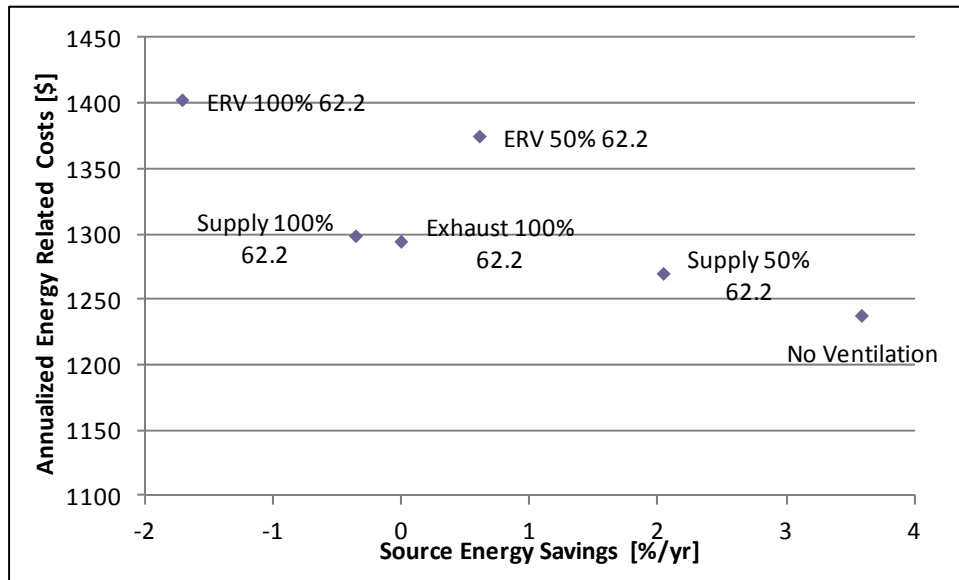

**Figure 2. Energy Savings and Costs: Vented Attic, 5% Duct Leakage**

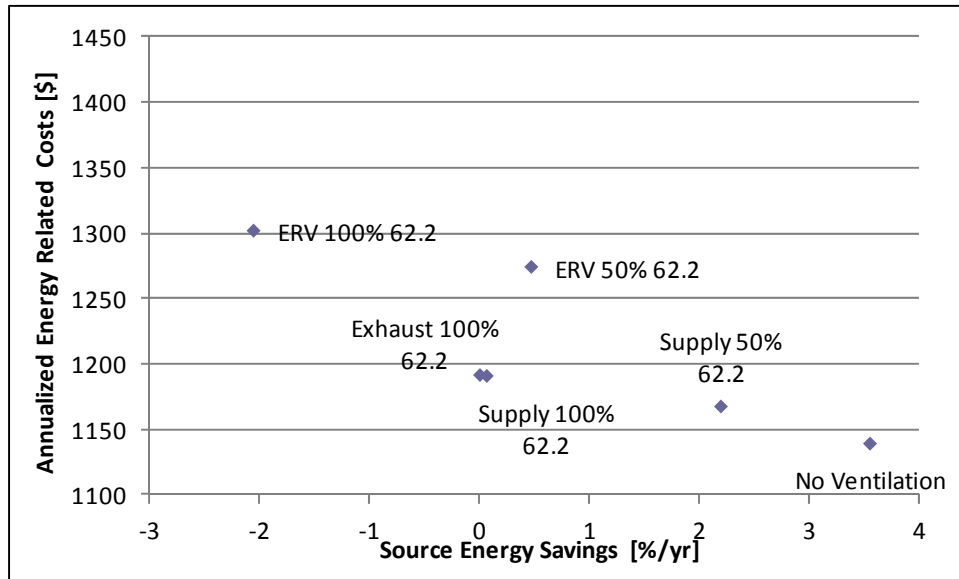

Figure 3: Energy Savings and Costs: Vented Attic, No Duct Leakage

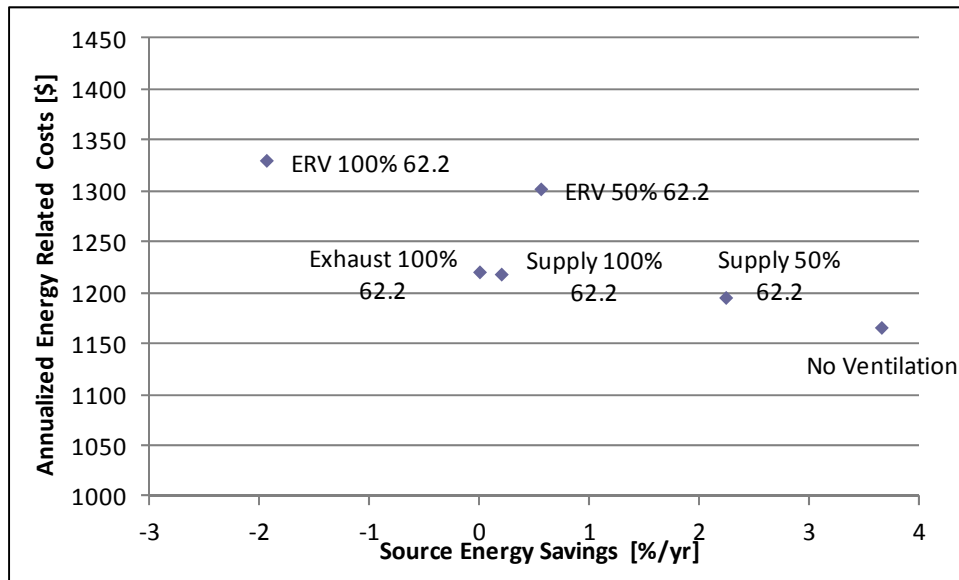

Figure 4: Energy Savings and Costs: Unvented Attic, No Duct Leakage

### 1.5 Tradeoffs and Other Benefits

Over-ventilation unnecessarily consumes energy and raises the risk of comfort and indoor air quality complaint problems due to elevated indoor humidity in warm-humid climates (Rudd and Henderson 2007). Higher performing ventilation systems may be able to eliminate unnecessary

over-ventilation, thereby providing equal or improved indoor air quality and comfort at lower cost.

## 2 Previous Research

Significant work has been done by the Building Science Consortium in the area of ventilation air distribution effectiveness under past Building America work which has been directed toward changes to ASHRAE Standard 62.2. Field testing and CONTAM (Walton et al. 2010) modeling associated with that work has shown that ventilation air distribution effectiveness varies widely between ventilation systems (Rudd and Lstiburek 2000; Rudd and Lstiburek 2001; Hendron et al. 2006; Hendron et al. 2007; Rudd and Lstiburek 2008; Townsend et al. 2009a; Townsend et al. 2009b). Utilizing high performing systems that draw outside air from a known fresh air location, and filter and fully distribute that air to the occupants breathing zone (including bedrooms where occupants spend the most continuous time), should allow for optimization of the ventilation rate to avoid problems of over-ventilation.

## 3 Test and Analysis Method

### 3.1 Description of the Test Houses

The project involved testing at two unoccupied, single-family, detached homes in Tyler, TX that were constructed as lab homes at the University of Texas – Tyler<sup>5</sup>. Figure 5 shows the campus location and directions to the test homes. The twin lab homes offered a unique opportunity for the direct comparison of nearly identical homes except for House 1 (H1) having a vented attic (see Figure 6) and House 2 (H2) having an unvented attic assembly<sup>6</sup> (also known as sealed cathedralized attic). House 1 had 2x4 frame walls with netted and blown fiberglass insulation, and loose blown fiberglass insulation on the floor of the attic. House 2 had 2x6 advanced-framed walls with low-density spray foam insulation in the walls and under the attic roof deck. The homes were completely finished, with kitchen and bathroom cabinets, but were unfurnished. This allowed an evaluation focus on the building elements themselves, avoiding conflation with items particular individuals bring into their homes (Hodgson et al. 1997). Figure 7 shows exterior views of the test homes. H1 has the darker colored roof and H2 the lighter colored roof. Figure 10 shows the H1 floor plan layout, which applies to both houses since the plans are simply flipped (mirrored) with respect to each other.

Zone designations for the testing were as follows:

- **Main** zone included the kitchen, dining area, living area, foyer, and family bathroom;
- **Master** zone included the master bedroom, master bathroom, and walk-in closet;
- **Front** zone was the bedroom on the front side of the house (labeled Bedroom 2 in Figure 10);
- **Middle** zone was the bedroom between the master bathroom and the family bathroom (labeled Bedroom 3 in Figure 10);

<sup>5</sup> Learn more at [www.UT Tyler.edu/TxAIRE/Technology/Houses](http://www.UT Tyler.edu/TxAIRE/Technology/Houses)

<sup>6</sup> Refer to IRC section R806.4



- **Attic** zone was the vented attic for House 1 (including the vented attic over the garage) and the unvented attic for House 2 (the vented attic over the garage for House 2 was separate from the unvented attic and the garage but was not monitored as a separate zone); and
- **Garage** zone was the 2-car garage.

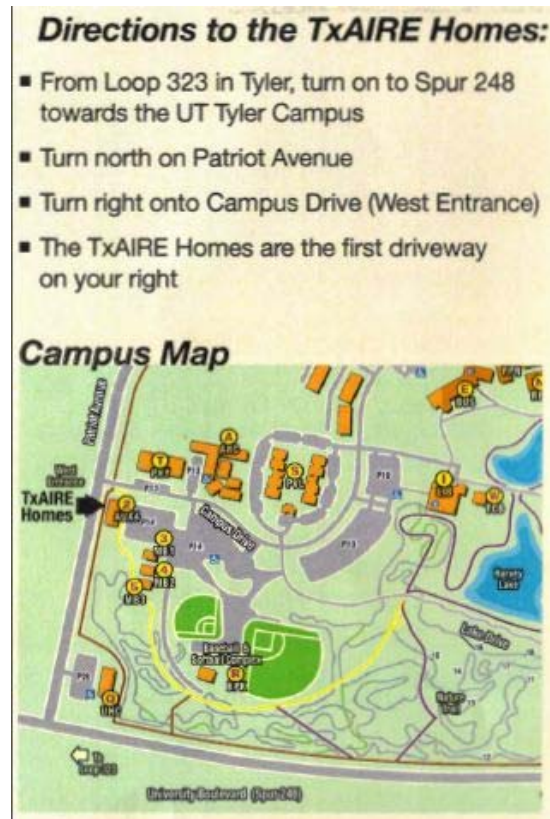

Figure 5. Location and directions to the test homes at University of Texas-Tyler



Figure 6. House 1 vented attic (left) and House 2 unvented attic (right)



Figure 7. Exterior photos of the test homes at the University of Texas-Tyler; House 1 has the darker roof

### 3.2 HVAC System Modifications and Pre-Testing

In order to test both houses with the same ventilation systems, the following HVAC system modifications were made prior to testing:

- An Energy Recovery Ventilator (ERV) system was installed in House 1 to be identical to the one installed in House 2 (see Figure 8).
- Provisions were made with a 6” wye fitting and damper arrangement such that the outside air duct serving each ERV could be switched to serve as the outside air duct for a newly installed central-fan-integrated supply (CFIS) ventilation system. A timer and relay arrangement was installed that controlled the central system fan and an inline supply fan to provide the desired supply ventilation airflow at the desired fan duty cycle . The outside airflow was set by a balancing damper and calibrated flow measuring station (see Figure 9).
- The same timer that controlled the central fan for the CFIS system was used to control the central fan for the exhaust with mixing system.



Figure 8. Energy Recovery Ventilator installed in House 1 to match that of House 2



**Figure 9. Wye'd outside air duct, airflow stations, and inline fan for retrofitting a CFIS ventilation system in each attic (left); setting the CFIS airflow rate with Iris damper airflow station (top); fan timer and relay arrangement (bottom)**

# HOUSE 1

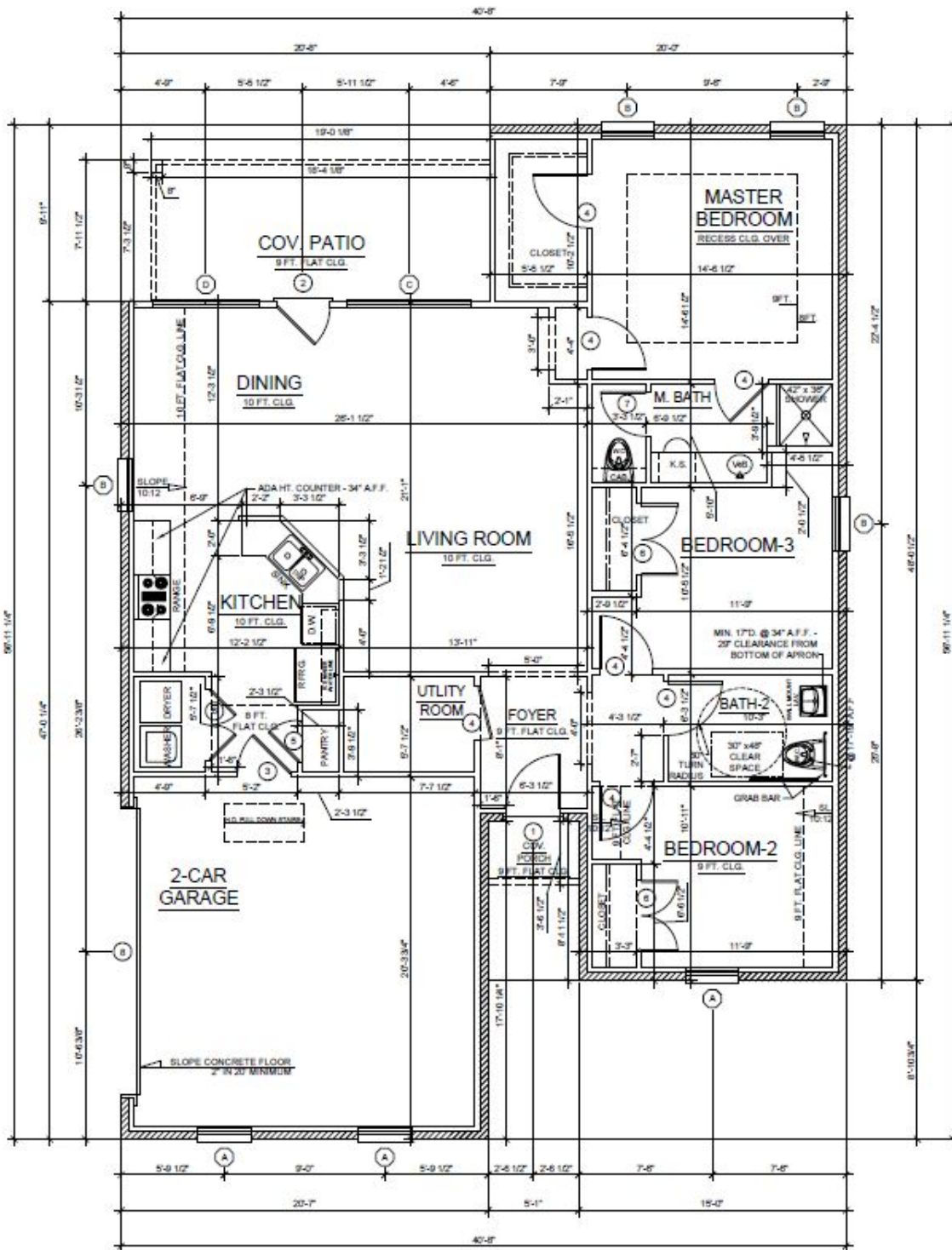

Figure 10. Test house floor plan

### 3.3 Testing Approach

The objective of the test program was to compare the whole-building, multi-zone, indoor air quality performance of continuous exhaust ventilation, central-fan-integrated supply ventilation, and energy recovery ventilation. The homes were completely finished, with kitchen and bathroom cabinets, but were unfurnished and unoccupied. This allowed an evaluation focus on the building elements themselves, avoiding conflation with occupant activities and items particular individuals bring into their homes. The testing approach taken was a combination of:

- Building enclosure and building mechanical systems characterization by measurement of building enclosure air leakage, central air distribution system airflows, and ventilation system airflows.
- Field tracer gas work using per-fluorocarbon tracer gases (PFT's) to determine zone air change rates and inter-zonal airflows with different ventilation systems operating.
- Multi-zone sampling of volatile organic compounds (VOC), formaldehyde (HCHO), and airborne particulates to determine indoor air quality impacts as a function ventilation system operation.
- A preliminary CONTAM airflow network simulation model constructed from the detailed building enclosure and building mechanical systems characterization testing (see Appendix B).

Table 2 provides a listing of the five tests conducted in each house, showing the designated test number, test name, and brief description. The test configurations were intended to represent normal limiting case conditions for most homes whereby space conditioning equipment may not operate for long periods (overnight to days long) and bedroom doors are closed at night.

The testing was originally planned for end of May to early June in order to avoid unreasonable indoor conditions without space conditioning operating, but that schedule could not be met, so the testing was delayed until early October. Figure 11 through Figure 13 show the indoor and outdoor conditions during each test period. Temperature and relative humidity in each zone and outside were measured with new HOBO U12-011 data loggers recording on a 5 minute interval dataloggers. Wind direction, and average and maximum values of wind speed were recorded on 5-minute intervals by the data collection system that existed at the houses. The pole-mounted anemometer and wind vane was mounted on the roof of House 2.

The first 12-hour period of each test was to achieve steady-state for the purposes of PFT, particulate, VOC, and formaldehyde sampling in the second 12-hour period of each test. The test sequence was scheduled such that the 12-hour period for sampling would be overnight. The PFT source emission rates are coarsely temperature dependent, which was accounted for in the analysis, but since we were not conditioning the buildings during the testing, we did not want to risk solar heating effects having an impact on the sources. We also wanted to limit wind as a potentially confounding factor by taking advantage of generally lower wind conditions at night. The overnight ventilation condition is a normal and important condition in homes and there was no need to complicate the testing and data analysis with external factors of daytime solar heating and wind. Figure 13 shows the start (green triangle marker) and stop (red triangle marker) times

of the 12-hour sampling period of each test period, being evening to morning. The sixth test period shown in that Figure 13 is a re-test of the House 2 Baseline test.

A general note is that all closet doors were left open to allow that air volume to fully interact with the adjoining space, and all bedroom doors were configured to have the same 1/2” undercut above the decoratively stained concrete floors throughout the houses.

**Table 2. Test number, name, and description of the five tests conducted in each house**

Test Number	Test Name	Test Description
1	Baseline	No ventilation, bedroom doors closed, no central fan operation
2	Exhaust	Exhaust ventilation from master bathroom, bathroom door open to bedroom, bedroom doors closed, no central fan operation
3	Exh w/mixing	Exhaust ventilation from master bathroom, bathroom door open to bedroom, bedroom doors closed, 20% central fan operation (48 off / 12 on)
4	CFIS	Central-fan-integrated supply (CFIS) ventilation, bedrooms closed, 33% central fan duty cycle (20 off / 10 on)
5	ERV	Balanced (ERV) ventilation, bedrooms closed, no central fan operation

### **3.3.1 Baseline Test**

The Baseline test was conducted to benchmark all measured parameter with no ventilation system or space conditioning system operating.

### **3.3.2 Exhaust Test**

The exhaust test was conducted using the master bathroom fan because BSC experience has been that that fan is most often the larger and better of the bathroom and toilet room fans in new houses. For testing, the continuous exhaust ventilation flow was adjusted to 45 cfm to meet the ASHRAE Standard 62.2-2010 continuous fan flow rate for the 1475 ft<sup>2</sup>, 3-bedroom houses.

### **3.3.3 Exhaust With Mixing Test**

The exhaust with central air distribution system mixing test, with a central system fan cycle of 48 minutes off and 12 minutes on, was conducted to see the effects of trying to achieve better ventilation air distribution effectiveness via whole-house mixing of ventilation air drawn in by the exhaust fan through unknown locations in the building enclosure. The intent was to achieve a 0.7 recirculation turnover factor which BSC has worked with the ASHRAE 62.2 Standard committee to implement. Additional exhaust ventilation testing was contemplated, using the lavatory bathroom off of the main area, but was eliminated due to budget constraints.

### **3.3.4 Central-Fan-Integrated Supply Test**

The central-fan-integrated supply (CFIS) ventilation system test was conducted to evaluate the performance effects of drawing outside air from a planned outdoor air location, and filtering and fully distributing that air to each conditioned space zone. The outside air ventilation supply airflow was set at 135 cfm by means of a calibrated flow station (Iris damper), and the central system fan was controlled to operate on a 33% duty cycle, 20 minutes Off / 10 minutes On. The central system return air filters were new, 1 inch thick 3M Filtrete 700 filters, being given a “Better” ranking by the manufacturer (in a field of Good, Better, Best) and a Microparticle Performance Rating (MPR) of 700 (in a field of 300, 600, 700, 800, 1000, 1085, 1200, 1500, 1900, and 2200). The MPR measures a filter's ability to capture particles between 0.3 and 1.0 micron. The manufacturer states that the Filtrete 700 used in this testing is intended for attracting and capturing some microscopic allergens like smoke and smog particles and large allergens like dust, mold spores and pet dander from the air passing through the filter. The ASHRAE Minimum Efficiency Reporting Value (MERV) reports a filter's ability to capture particles between 3 and 10 microns. Manufacturer literature has related the Filtrete 600 roughly to a MERV 8, the 1000 to a MERV 11, and the 1250 to a MERV 12.

### **3.3.5 Energy Recovery Ventilator Test**

The energy recovery ventilator (ERV) test was conducted with a system independently ducted from the central air distribution system. The ERV ductwork in these houses was configured to exhaust from two locations in the main area and supply to all bedrooms. The ERV total supply airflow was measured to be 96 cfm so the ERV timer control was set for 50% runtime. The ERV included a washable course filter at the inlet of the heat and moisture energy recovery core within the unit. That filter was cleaned before testing began.



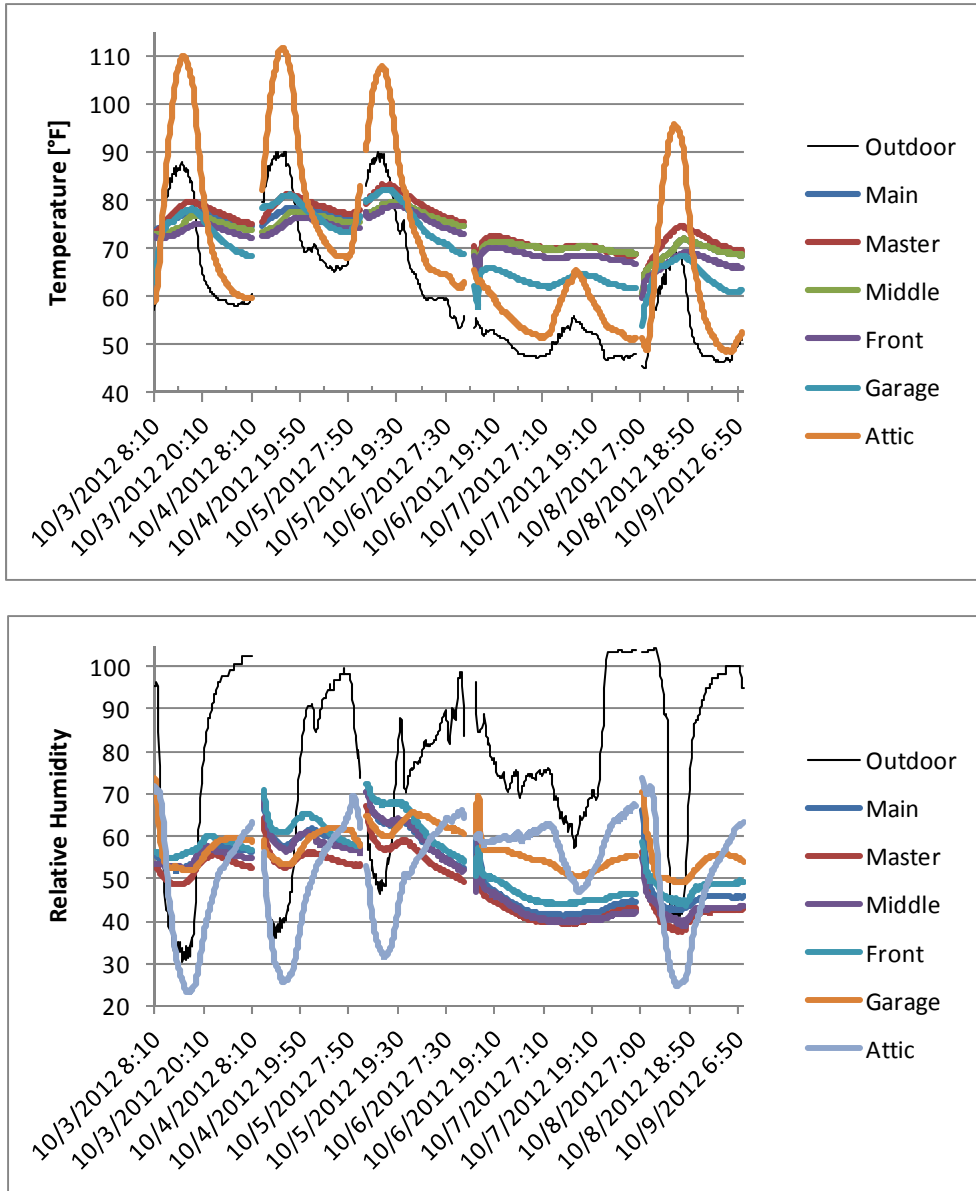

**Figure 11. House 1 temperature and relative humidity in indoor zones and outdoors during each test period**

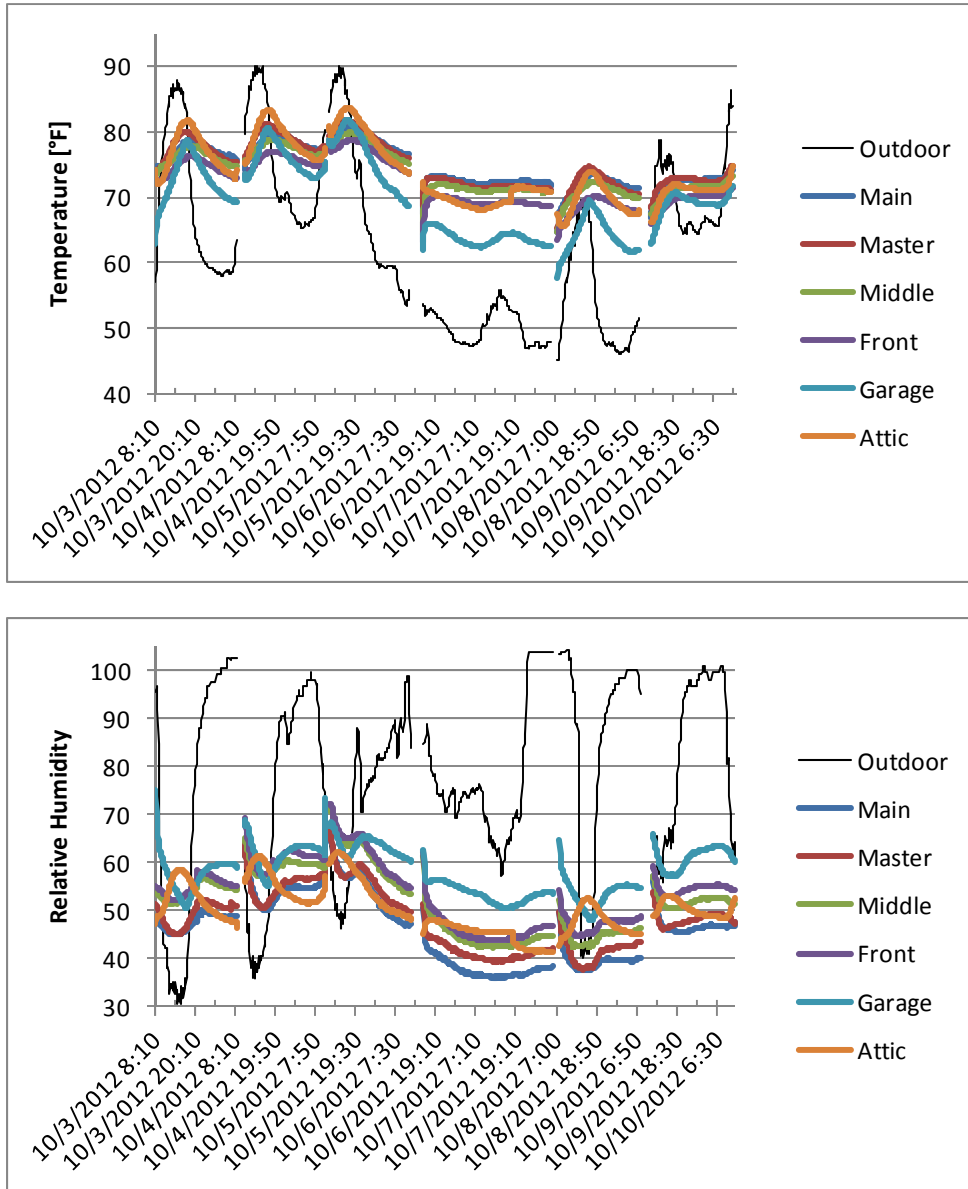
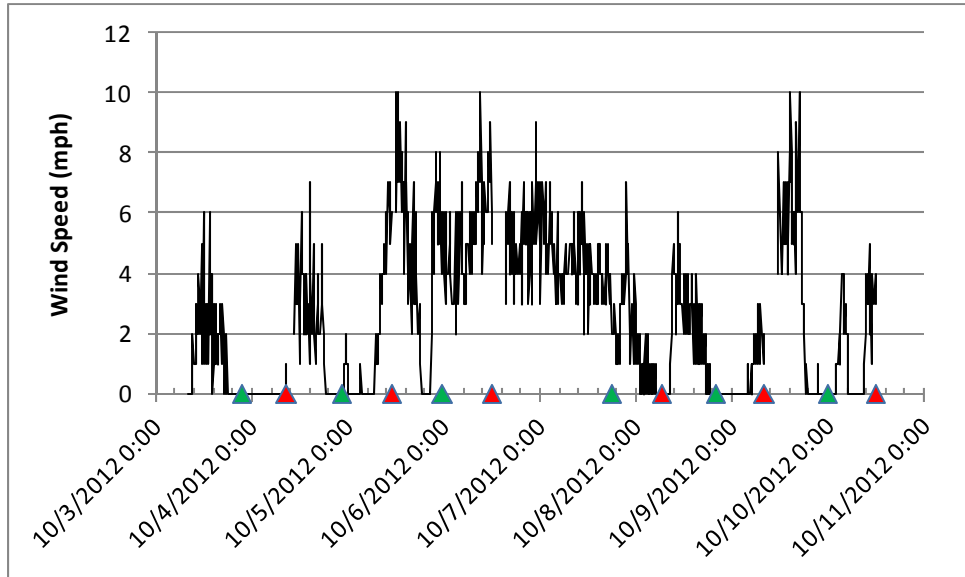

Figure 12. House 2 temperature and relative humidity in indoor zones and outdoors during each test period



**Figure 13. Wind speed during each of the test periods; green and red markers indicate start and stop of the 12-hour sampling periods**

### 3.4 Building Enclosure, Central Air Distribution System, and Ventilation Systems Characterization

For each of the two test houses, the building enclosure, central air duct system, and the ventilation systems were characterized by the following procedures to facilitate PFT data interpretation and CONTAM modeling:

1. Multi-point fan pressurization testing to establish the overall building enclosure air leakage rate.
2. Multi-point, guarded and unguarded air leakage testing by fan pressurization of individual zones to determine the air leakage of the zone to exterior and zone-to-zone.
3. Total duct leakage and duct leakage to outside testing.
4. Central space conditioning system airflows.
5. Local exhaust and whole-building ventilation system flow rates.

### 3.5 PerFluorocarbon (PFT) Tracer Gas testing

Each of the two houses was tested with six different tracer gas sources, one for each of the six zones. The type and number of tracer gas sources used in each house and test is shown in Table 3. The PFT testing part of the project was set up and executed in consultation with Brookhaven National Laboratory (BNL) staff<sup>7</sup> and in accordance with the prepared instructions provided by BNL (Dietz 2006) for the Air Infiltration Measurement System (AIMS). Detailed explanation

<sup>7</sup> Terry Sullivan, PhD, Deputy Division Head, Environmental Research and Technology Division, Brookhaven National Laboratory, 75 Rutherford Drive, Building 815, Upton, NY 11973

and statistical support for the PFT methods and AIMS analysis is provided in Leadererr et al. 1995 and Dodson et al. 2007.

**Table 3. Type and number of tracer gas sources used in each house and test**

<b>House 1, Test 1 (10/3)</b>								
<b>Zone Name</b>	<b>Floor Area (ft<sup>2</sup>)</b>	<b>Height (ft)</b>	<b>Volume (ft<sup>3</sup>)</b>	<b>PFT</b>	<b>Color</b>	<b>RSS</b>	<b>Qty</b>	<b>Resulting RSS</b>
H1 Attic, vented	1463	9.2	13507	PDCB	brown	1	1	1.00
H2 Attic, unvented	1463	9.2	13507	PDCB	brown	1	1	1.00
Main	738	9.8	7220	PMCH	red	0.93	1	0.93
Garage	419	9	3771	PMCP	gold	0.62	1	0.62
Master bed	337	8.2	2766	ocPDCH	blue	0.16	5	0.80
Front bed	165	9	1485	1-2PTCH	silver	0.12	6	0.72
Middle bed	159	8	1272	iPPCH	purple	0.25	3	0.75
1/2 Bath (open to Main)	64	8	512					
<b>House 2, Test 1 (10/3)</b>								
<b>Zone Name</b>	<b>Floor Area (ft<sup>2</sup>)</b>	<b>Height (ft)</b>	<b>Volume (ft<sup>3</sup>)</b>	<b>PFT</b>	<b>Color</b>	<b>RSS</b>	<b>Qty</b>	<b>Resulting RSS</b>
H1 Attic, vented	1463	9.2	13507	PDCB	brown	1	1	1.00
H2 Attic, unvented	1463	9.2	13507	PDCB	brown	1	1	1.00
Main	738	9.8	7220	PMCH	red	0.93	1	0.93
Garage	419	9	3771	PMCP	gold	0.62	1	0.62
Master bed	337	8.2	2766	1-2PTCH	silver	0.12	6	0.72
Front bed	165	9	1485	ocPDCH	blue	0.16	5	0.80
Middle bed	159	8	1272	iPPCH	purple	0.25	3	0.75
1/2 Bath (open to Main)	64	8	512					
<b>House 1 and House 2 Tests 2-5, and House 2 Test 6 (beginning 10/4) (re-assigned to optimize by volume and resulting relative source strength)</b>								
<b>Zone Name</b>	<b>Floor Area (ft<sup>2</sup>)</b>	<b>Height (ft)</b>	<b>Volume (ft<sup>3</sup>)</b>	<b>PFT</b>	<b>Color</b>	<b>RSS</b>	<b>Qty</b>	<b>Resulting RSS</b>
H1 Attic, vented	1463	9.2	13507	PDCB	brown	1	1	1.00
H2 Attic, unvented	1463	9.2	13507	PDCB	brown	1	1	1.00
Main	738	9.8	7220	PMCH	red	0.93	1	0.93
Garage	419	9	3771	ocPDCH	blue	0.16	5	0.80
Master bed	337	8.2	2766	iPPCH	purple	0.25	3	0.75
Front bed	165	9	1485	1-2PTCH	silver	0.12	6	0.72
Middle bed	159	8	1272	PMCP	gold	0.62	1	0.62
1/2 Bath (open to Main)	64	8	512					

The PFT sources supplied by BNL were contained in a metal tube (see Figure 15) and were always emitting gas at a predictable rate through a stopper at the top. The emission rate of the PFT sources is affected by temperature, so temperature and relative humidity was monitored in each zone and used by BNL in the analysis. Zone temperature and RH measurement was by new HOBO U12-011 data loggers recording on a 5 minute interval. Per BNL instructions, a box fan placed in the attics was used to facilitate mixing within that zone (see Figure 6). That is especially important in vented attics to minimize wind driven effects that could bias normal gas

diffusion distribution of PFT source, where prevailing winds can dominate by pushing air in one side and out the other.

Between each test the PFT sources were sealed in doubled, heavy-duty re-sealable bags (bag within another bag) and left in their respective zone while the house was flushed with outdoor air to a minimum of 10 complete air changes using a blower door and open windows and doors. An exhaust fan in the unvented attic aided flushing of that space to the garage attic and to outside.

To start each test, the PFT sources were opened in their respective zone for 12 hours with the appropriate ventilation system operating to reach reasonable steady-state conditions. The PFT samplers (CATS - Capillary Adsorption Tube Sampler) were not deployed (capped and not near any sources) during that initial 12 hour period. Then, the samplers were placed in each zone and uncapped for the next 12 hours to complete the test.

A total of sixty primary samples were taken (2 houses, 5 tests, 6 zones per test), and a total of sixty back-up samplers were taken to be analyzed if data from any primary samples were suspect or for general quality assurance (QA)/quality control (QC) purposes. All six backup samplers were analyzed for one test (H2-Test 2) based on an observation question (we wanted to verify the result that the Attic to Main airflow was low in House 2 compared to House 1) and for a general QA/QC check. The results showed only minor differences between the two sets of data and the AIMS air flow analysis (refer to Figure 27). Figure 15 shows primary and back-up CATS mounted on the sampling fixture.



**Figure 14. House 2 Main zone with PFT source tripod on left and sampling station tripod on right**



**Figure 15. PFT source (left) and primary and backup CATS (right)**

### **3.6 Airborne Particulate Sampling**

During the 12-hour quasi steady-state period of each PFT test period, air sampling for airborne particulates was conducted in the main (common area) and master bedroom zones (see Figure 17 and Figure 18). During some tests, additional particulate sampling was done outdoors, and in the garage and attic of each house. Particulates were monitored at six particle sizes (0.3, 0.5, 1.0, 2.0, 5.0, 10.0 micrometer) with a Fluke model 985 laser airborne particle counter. The meter has a counting efficiency of 50 % @ 0.3  $\mu\text{m}$  and 100 % for particles  $> 0.45 \mu\text{m}$ . The sample flow rate was 0.1 cfm (2.83 L/min). The meter was programmed to complete 48 cycles of 15 minute samples over the second 12-hour period of each test, gathering a sample volume of 1.5  $\text{ft}^3$  (42.45 L) each cycle. Data was recorded electronically and imported into a worksheet for analysis. Only the last twenty-one 15 minute particle counting cycles (cycles 20 through 40), or the last 5.25 hours before researchers re-entered the houses were used for analysis. This was to analyze the data closest to steady-state and to isolate the particle load attributable to the operation of different ventilation systems from any occupant (researcher) interaction. Occupant interaction can be significant, especially in the larger particle sizes as shown at the beginning and end of the test in Figure 16.

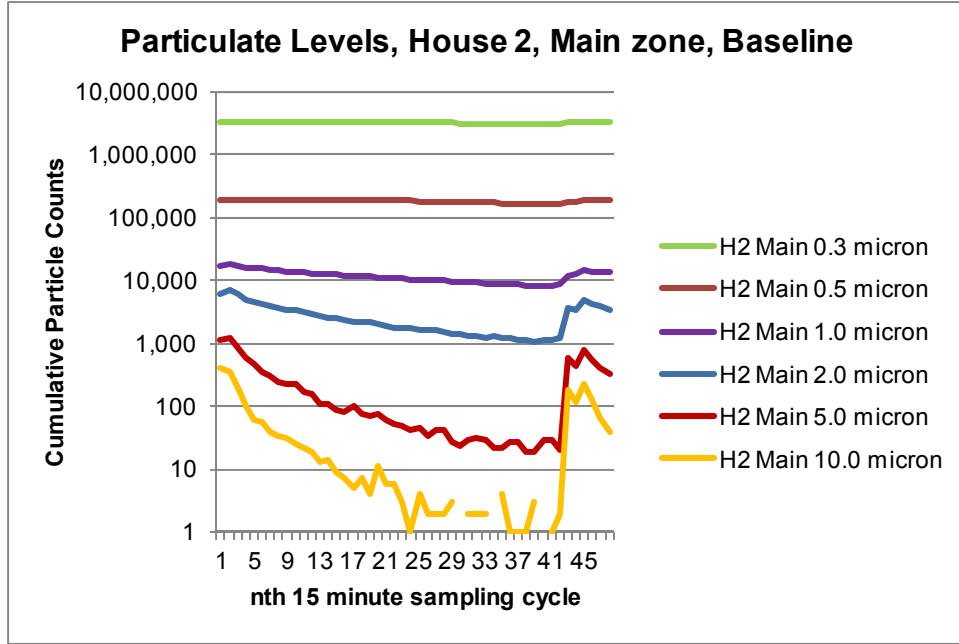
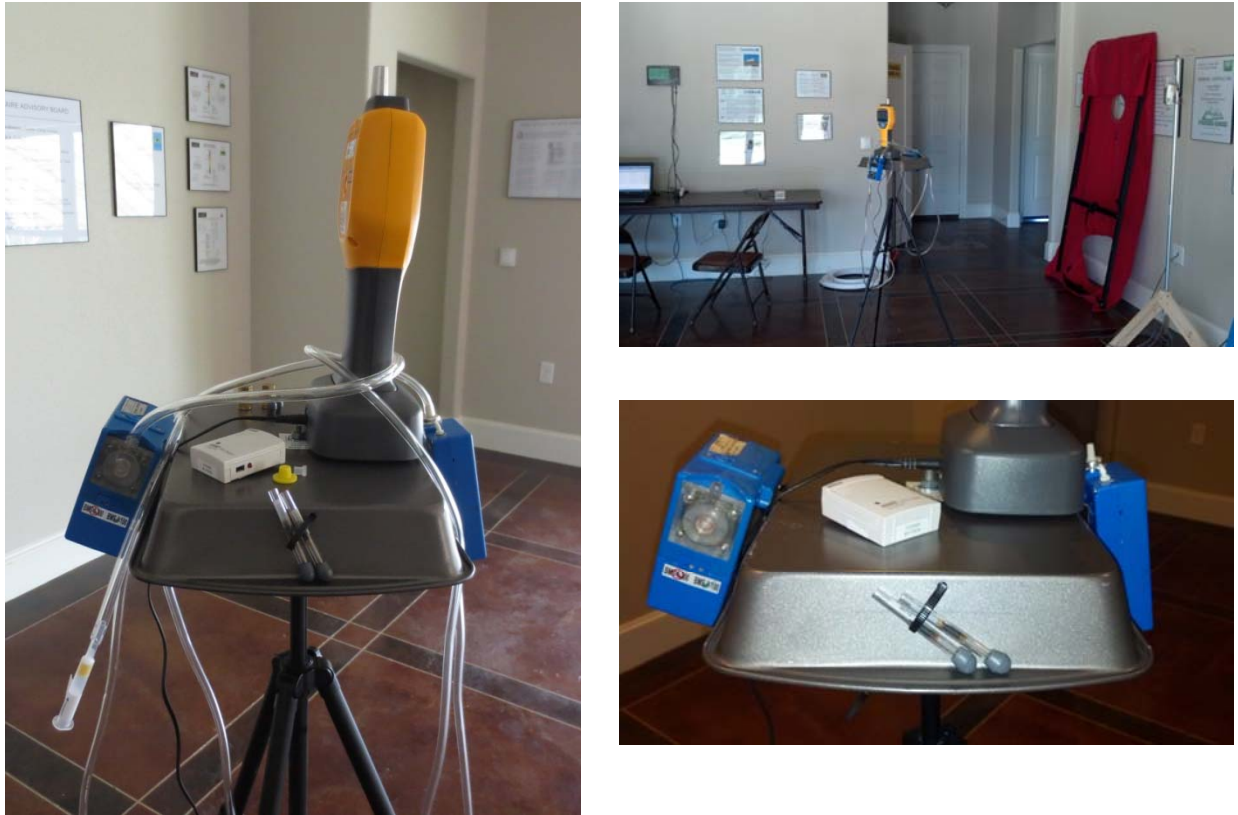

Figure 16. Cumulative particle counts for six particle sizes during the Baseline test in House 2, Main zone; results show impact on large particle counts due to human disturbance 1.5 hour before end of sampling period



**Figure 17. Test fixture tripod holding (left to right in photos) formaldehyde sample pump, temperature and relative humidity datalogger, PFT sample tubes (CATS), airborne particulate counter, and VOC sampling pump**

### 3.7 Volatile Organic Compound Sampling

Ninety minutes before the end of the 12-hour steady-state period of each PFT test period, volatile organic compounds (VOCs) sampling was conducted in the main (common area) and master bedroom zones (see Figure 18). During some tests, additional VOC sampling was done in the garage and attic of each house. An 18 L air sample was collected in each case. The solid sorbent samplers and the calibrated low-flow sample pumps (0.2 L/min) were provided by Air Quality Sciences division of Underwriters Laboratory (UL-AQS). Laboratory analysis of the samples was also conducted by UL-AQS, with a report identifying the “Top 20” VOCs (by concentration) identified in each sample for each test<sup>8</sup>.

<sup>8</sup> VOC samples collected on solid sorbents and analyzed by thermal desorption/mass spectrometry according to AQS Method CLI023 (based on USEPA Compendium Method TO-17 and ASTM 6196). Individual compounds and TVOC (total volatile organic compounds) are calibrated relative to toluene. Values below 2.0  $\mu\text{g}/\text{m}^3$  are for information purposes only. Chemical was detected, but below the quantifiable level of 0.04  $\mu\text{g}$  based on a standard of 18 L air collection volume. AQS’ quality assurance program monitors blank sorbent media to ensure that the residual background does not exceed AQS’ quality objective of  $\leq 36$  ng of total VOC. Quality Assurance Report available at [www.aqs.com](http://www.aqs.com).





Figure 18. VOC sampling pump and solid sorbent sample tube; airborne particulate counter on top of sampling fixture

### 3.8 Formaldehyde Sampling

Sixty minutes before the end of the 12-hour steady-state period of each PFT test period, formaldehyde (HCHO) sampling was conducted in the main (common area) and master bedroom zones (see Figure 17). During some tests, additional VOC sampling was done in the garage and attic of each house. A 60 L air sample was collected in each case. The DNPH samplers and the calibrated sample pumps (1.0 L/min) were provided by UL-AQS. Laboratory analysis of the samples was also conducted by UL-AQS, with a report identifying the formaldehyde concentration identified in each sample for each test<sup>9</sup>.

<sup>9</sup> Analysis by DNPH/HPLC according to AQS Method CLI022 (based on ASTM Method D5197). Any values below 2.0  $\mu\text{g}/\text{m}^3$  are for information purposes only; chemical was detected, but below the quantifiable level of 0.12  $\mu\text{g}$  based on a standard of 60 L air collection volume. Reported concentrations based on 60.0 L of volume sampled. Field blanks are not intended to have a measurable amount of air sampled. Quality Assurance Report available at [www.aqs.com](http://www.aqs.com).

## 4 Discussion of Results

### 4.1 Building Air Leakage Characterization

#### 4.1.1 Fan Pressurization Tests

In June and October 2012, air leakage characterization of the two test houses was conducted using automated and non-automated fan pressurization techniques. Multiple calibrated fans (blower doors and ductblasters) were used, and pressure measurement was recorded in each zone with respect to outside. Table 4 gives the physical characteristics of each house needed for normalizing the test results. Detailed building and zonal leakage test results, including those from numerous guarded tests designed to assist with future modeling efforts, are given in Appendix B.

Typically reported summary results of blower door testing for each house is given in Table 5. House 2, with the unvented attic house with spray foam under the roof deck, had 789 cfm<sub>50</sub> leakage compared to 1048 cfm<sub>50</sub> leakage for House 1 with a vented attic. Referring to Table 4, the volume and exterior surface area of House 2 are 102% and 32% greater than that of the House 1, respectively, illustrating the importance of air sealing the unvented attic.

**Table 4. Physical characteristics of the test houses**

Zone Name	Floor Area (ft <sup>2</sup> )	Max Height (ft)	Volume (ft <sup>3</sup> )	Perimeter (ft)	Exterior Wall Area (ft <sup>2</sup> )	House 1 Exterior Surface Area <sup>2</sup> (ft <sup>2</sup> )	House 2 Exterior Surface Area <sup>2</sup> (ft <sup>2</sup> )
Main	750	10.0	7220	47	472	1972	1222
Master	337	9.0	2766	48	433	1107	770
Middle	159	8	1272	13	100	418	259
Bath	64	8	512	6	50	178	114
Front	165	9	1485	35	315	645	480
House 1 Total	1475	44	13255	149	1370	4320	
Attic (House 2) <sup>1</sup>	1475		13507				2860
House 2 Total	1475	44	26762	149	1370		5705
% diff. H2/H1			102%				32%
<sup>1</sup> Attic volume and roof surface from AutoCAD 3D model							
<sup>2</sup> Exterior surface area includes the slab floor, walls and roof							

**Table 5. Typically reported blower door test results for each test house**

	Conditioned Floor Area (ft <sup>2</sup> )	Conditioned Volume (ft <sup>3</sup> ) <sup>1</sup>	Surface Area <sup>2</sup>	C	n	CFM50	ACH50	CFM50 per ft <sup>2</sup> surface area	EqLA <sup>3</sup> (in <sup>2</sup> )	ELA <sup>4</sup> (in <sup>2</sup> )	SLA <sup>5</sup>
House 1	1,475	13,255	4,320	66.2	0.706	1048	4.74	0.24	99	49.94	2.35
House 2	1,475	26,762	5,705	67.1	0.63	789	1.77	0.14	84	45.56	2.14
<sup>1</sup> For House 2, volume includes the unvented attic which is inside conditioned space but not actively conditioned											
<sup>2</sup> Exterior surface area includes the slab floor, walls and roof											
<sup>3</sup> Equivalent Leakage Area; EqLA = CFM10 * 0.2939											
<sup>4</sup> Effective Leakage Area; ELA = CFM4 * 0.2835											
<sup>5</sup> Specific Leakage Area; SLA = ELA / 144 / floor area * 10,000											

## 4.2 HVAC Characterization

Table 6 gives the results of duct leakage testing for both houses, and Table 7 gives the results of the cooling system room airflow testing for each house. The ventilation systems were set up to meet the ASHRAE Standard 62.2-2010 fan flow rate as shown in Table 8.

**Table 6. Duct Leakage Tests**

	<b>House 1 (CFM25)</b>	<b>House 2 (CFM25)</b>
<b>Total</b>	182	217
<b>To Outside</b>	56	30

**Table 7. Central air distribution system (heat pump) cooling supply airflows**

<b>Central AC Supply</b>		
<b>Room</b>	<b>House 1 (CFM)</b>	<b>House 2 (CFM)</b>
Living	89	43
	104	44
	122	60
	97	59
	134	82
	98	125
Mechanical Room	69	26
Master Bedroom	187	64
Master Bath	74	20
Master Closet	33	21
Middle Bedroom	63	67
Bath 2	42	21
Front Bedroom	25	75
<b>Supply Total</b>	<b>1137</b>	<b>707</b>

**Table 8. Ventilation system airflow and runtime setup**

<b>Exhaust (100% runtime)</b>		
	<b>House 1 (CFM)</b>	<b>House 2 (CFM)</b>
<b>Master bathroom</b>	45	45
<b>CFIS (33% runtime)</b>		
	<b>House 1 (CFM)</b>	<b>House 2 (CFM)</b>
<b>Flow station</b>	135	135
<b>Outside Air Intake</b>	109	100
<b>ERV (50% runtime)</b>		
<b>Room</b>	<b>House 1 (CFM)</b>	<b>House 2 (CFM)</b>
Master Supply	36	47
Middle Supply	27	25
Front Supply	30	24
<b>Supply Total</b>	<b>93</b>	<b>96</b>
<b>Outside Air Intake</b>	<b>116</b>	<b>96</b>
Exhaust Foyer	58	48
Exhaust Kitchen	80	75
<b>Exhaust Total</b>	<b>138</b>	<b>123</b>

### 4.3 PerFluorocarbon (PFT) Tracer Gas testing

PFT testing provided detailed information separately on individual zone outside air change rates and inter-zonal airflows. The testing materials were provided by BNL, the testing was done by BSC, the AIMS analysis was done by BNL, and the analysis and presentation of the AIMS results was done by BSC.

#### 4.3.1 Zone Air Change Rates

Figure 19 shows the individual zone air change rates for different ventilation systems in House 1. The air change rates were averaged over the final 12 hours of each 24 hour test. Infiltration and mechanically induced air change were combined in the PFT outside air change rate measurements. Fortunately, temperature differentials and wind speed were reasonably stable and similar during the testing periods so as to allow good comparison of zonal air change rates between the ventilation systems. The Baseline test (no mechanical ventilation) showed low air change rates throughout all zones, with the lowest being the Master and Middle bedroom zones. Continuous exhaust ventilation from the master bathroom increased the air exchange by about 0.1 ach over Baseline in the Main and Master zones, but the increase was less in the Middle and Front zones where the total air exchange rate remained below 0.1 ach. Exhaust with mixing (12 min/h via the central air distribution system) significantly improved the air change rate over Exhaust-only in the Middle and Front zones. Central-fan-integrated supply (CFIS) showed a significant improvement in air change rate over Exhaust-only in all but the Main zone. CFIS

showed an improvement over Exhaust with mixing only in the Master zone. The balanced ERV showed huge air change rate increases in the bedrooms but was about the same as the other ventilation systems in the Main zone. That was by-design since the ERV supplied fresh air only to the bedrooms and exhausted air only from the Main zone.

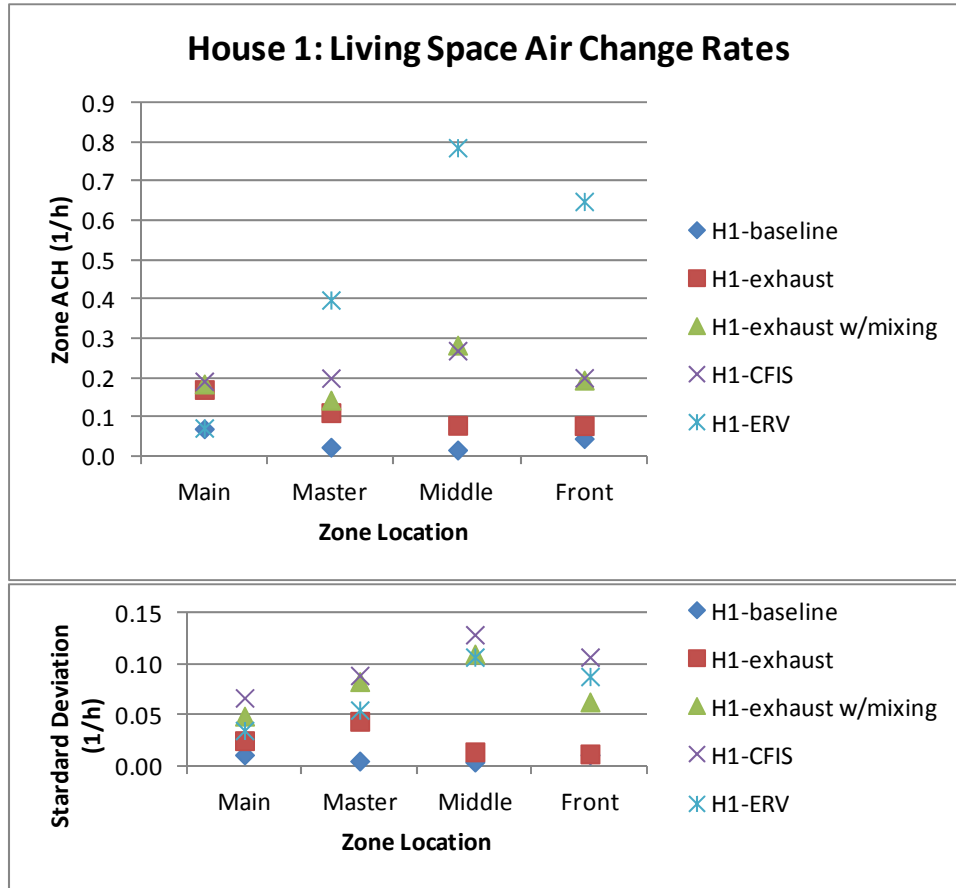

**Figure 19. Air change rates in the living space zones for House 1 (vented attic), for the Baseline test and four different ventilation systems**

Figure 20 shows the measured air change rates in the Garage and vented Attic zones. The Garage air change rate for all tests, regardless of ventilation system, was similar to the Baseline rates in the living space zones. The vented Attic air change rate was about 0.65 ach for all tests except it was double that for the Exhaust with mixing test. That can be explained by referring to Figure 13 and observing the wind speed during the sampling part (last 12 hours) of each test. The wind speed was 4-8 mph for the Exhaust with mixing test whereas it was 0-2 mph for all the other tests.

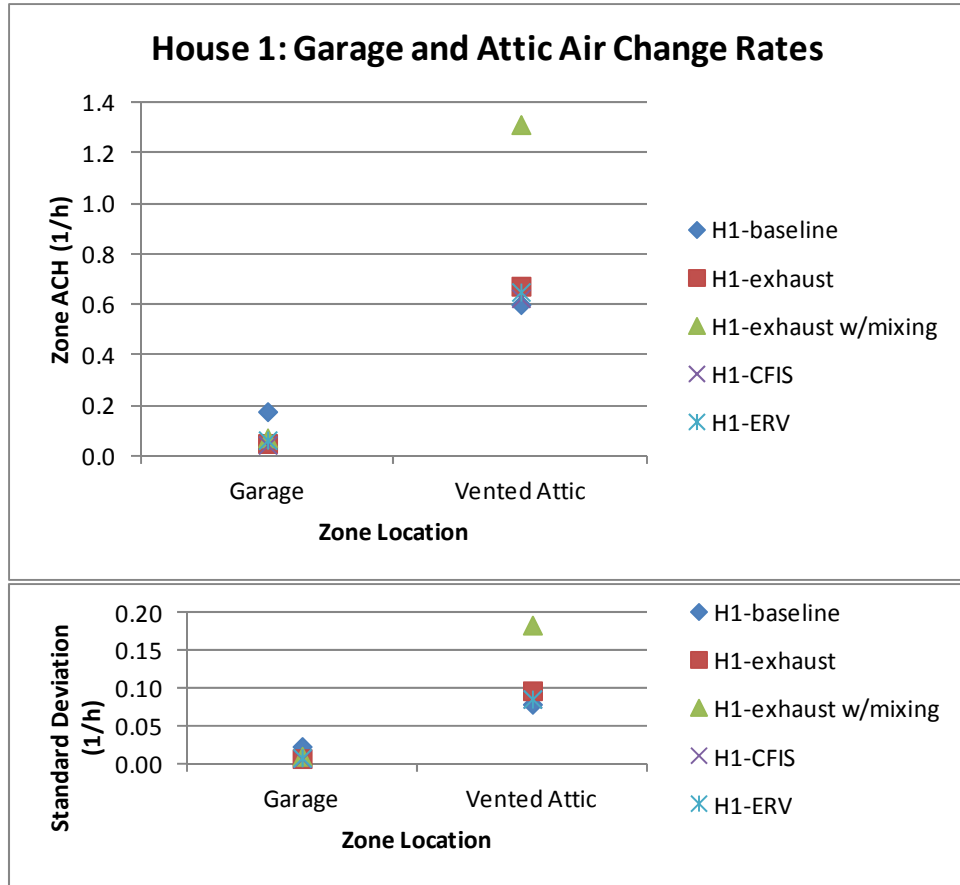

**Figure 20. Measured air change rates in the Garage and Attic zones for House 1, for different ventilation systems**

Comparing Figure 19 and Figure 21, it is evident that the living zone air change rates exhibit the same trends for both houses, confirming the reliability of the test methods. Comparing Figure 20 and Figure 22, the same is true for the Garage zones.

As expected, the Attic zones respond differently between the houses. In the unvented attic of House 2, the air change rates were very low, between about 0.02 and 0.04, for the Baseline, CFIS, and ERV tests. The air change rate increased five-fold, to between 0.16 and 0.18 ach, for both the Exhaust and the Exhaust with mixing ventilation systems. That points to the Exhaust ventilation system drawing ventilation air from the attic.

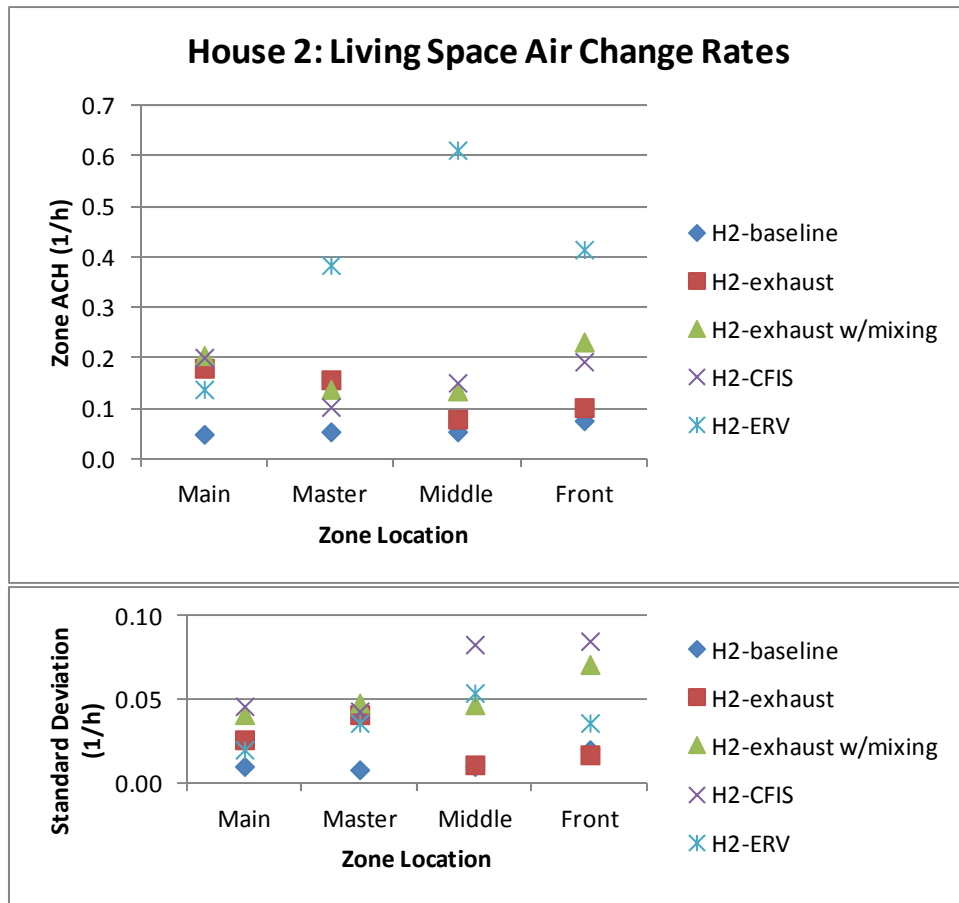

Figure 21. Air change rates in the living space zones for House 2 (unvented attic), for the Baseline test and four different ventilation systems, showing the same trends as House 1



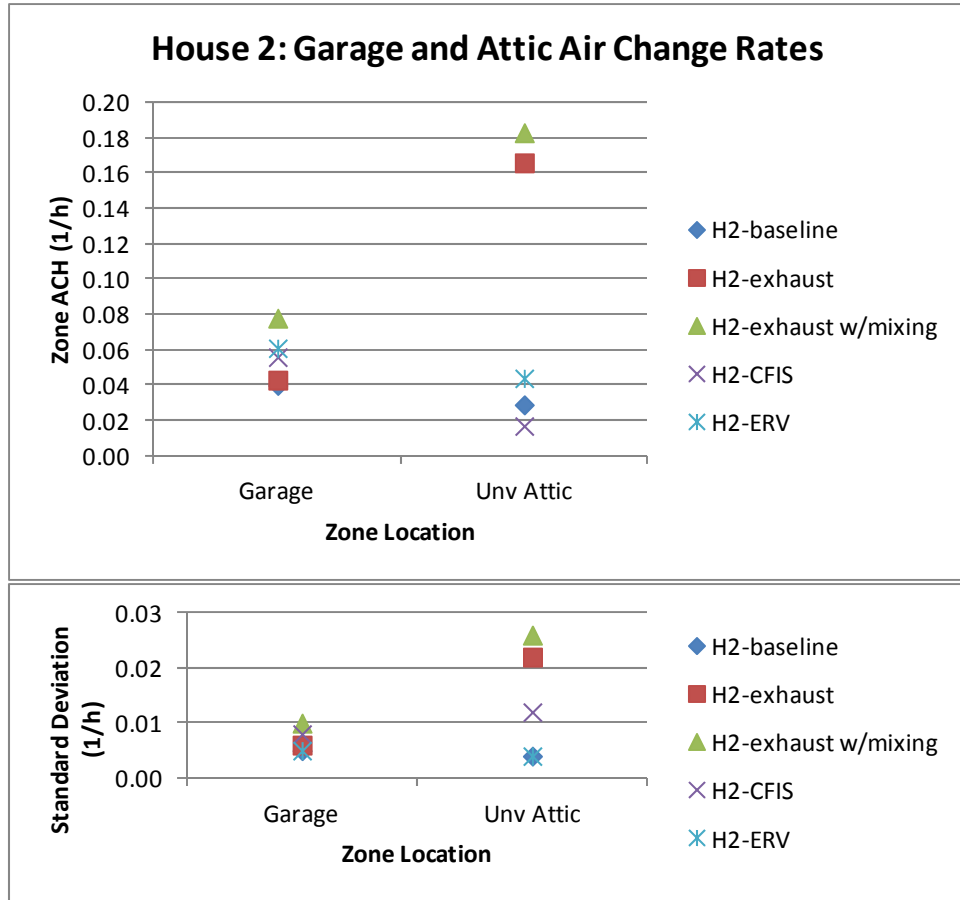

Figure 22. Measured air change rates in the Garage and Attic zones for House 2, for the Baseline test and four different ventilation systems

### 4.3.2 Inter-zonal Airflows

While the measured interzonal airflows have a higher degree of uncertainty than the zonal air change rates, as shown in Figure 23 and Figure 24, and as could be expected, the airflow from the Garage to the Main zone was the highest for the Exhaust ventilation systems. Airflow from the Garage to the Main zone was the lowest for the CFIS ventilation system and between Exhaust and CFIS for the ERV system. As a theoretically balanced system, the ERV system might be expected to behave just like the Baseline, but the fact that the ERV system was designed to supply to the bedrooms and exhaust from the Main zone set up a mechanically induced airflow imbalance within the multi-zone structure (Main being negative and bedrooms being positive) that shows up in this measurement. Airflow from the Garage to the bedroom zones was essentially negligible for all tests, but even so, airflow to the Master zone was slightly higher for the Exhaust systems, as makes sense since the exhaust fan was located there.

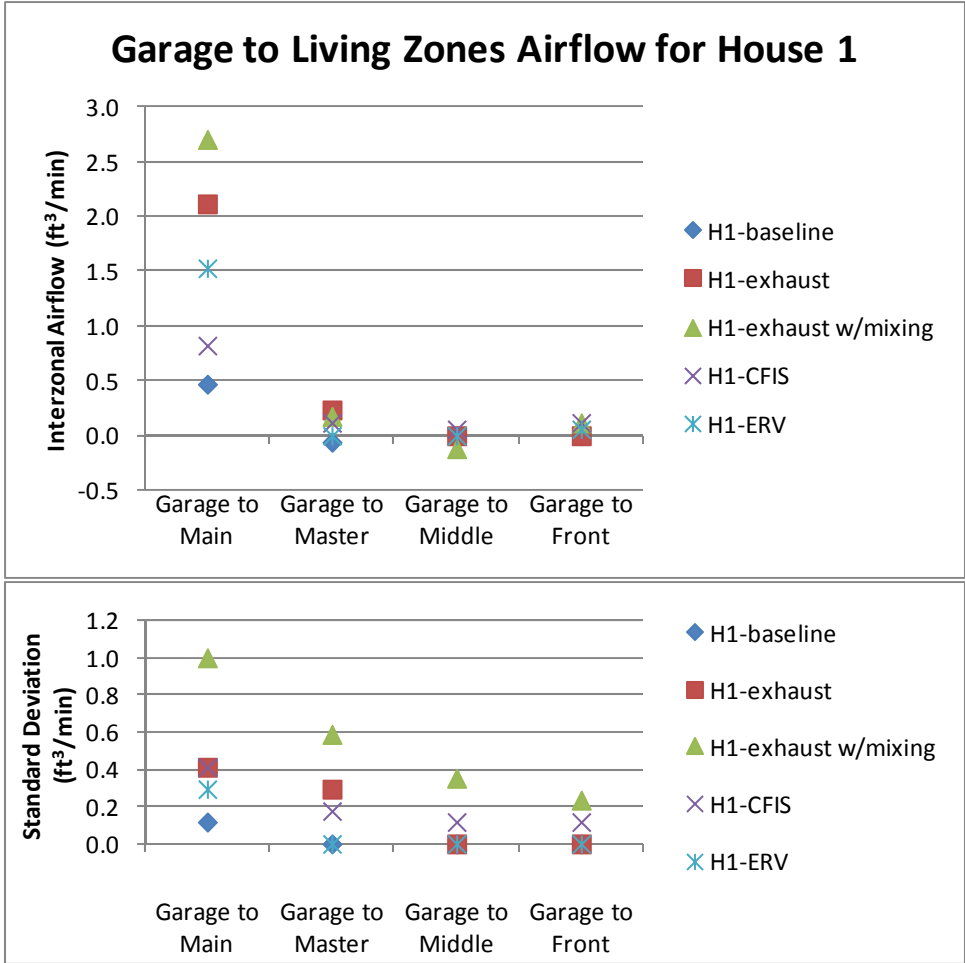
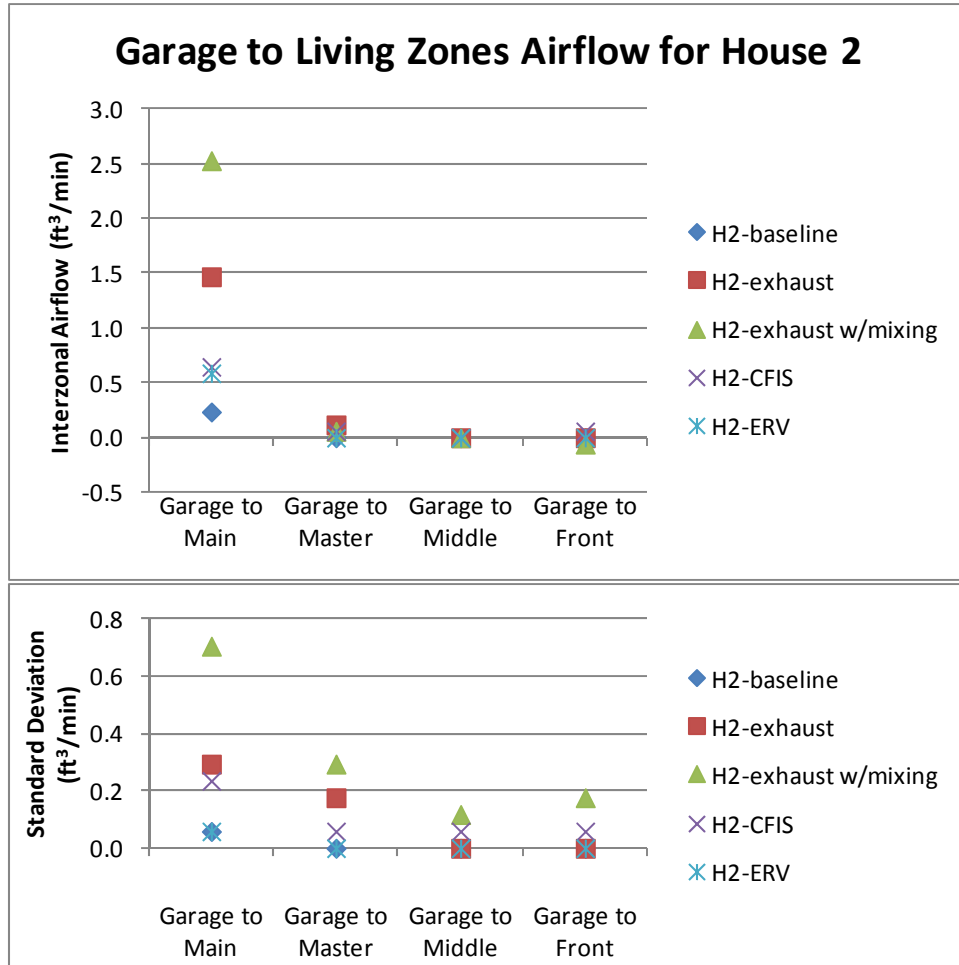

Figure 23. Airflow from Garage to living area zones in House 1, for the Baseline test and four different ventilation systems

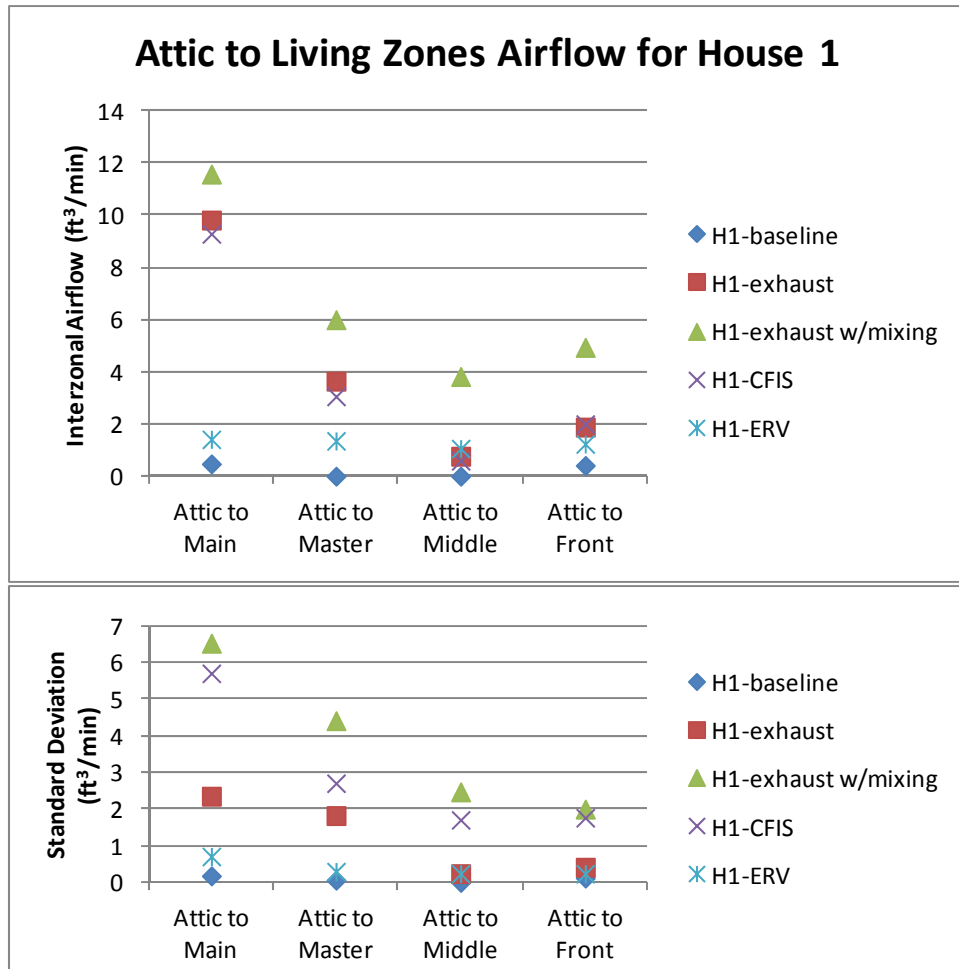

**Figure 24. Airflow from Garage to living area zones in House 2, for the Baseline test and four different ventilation systems, showing the same trends as House 1**

Airflow from the Attic (vented) to the living space zones for House 1 is shown in Figure 25. The Exhaust with mixing system consistently shows the highest airflow from the attic, followed by Exhaust, CFIS, ERV, and Baseline. By comparing the results for House 1 (Figure 25) with House 2 (Figure 26), it becomes clear that:

- a) The Exhaust system alone is moving 20% of its air ventilation air (10 cfm) from the vented attic in House 1 to the Main zone. About 7 cfm or another 14% of the Exhaust ventilation air in House 1 is moving from the Attic to the bedroom zones. A total of 34% (17 cfm out of 50) of the ventilation air for the Exhaust system in House 1 was coming from the vented attic. In comparison, for the unvented attic of House 2, the Exhaust system moved only 2% of its ventilation air from the Attic to the Main zone. This indicates that the exhaust makeup air resistance path to outside was greater through the unvented attic than through the vented attic and an Exhaust ventilation system may perform better in an unvented attic house.

b) In both houses, some central air distribution system return side leakage is causing the CFIS and Exhaust with mixing ventilation systems to move about 10 cfm of attic air to the Main zone. However, there is a big difference in ventilation effectiveness between the 10 cfm in a) and the 10 cfm in b). In a), it is 10 cfm out of 50 cfm of what was expected to be good ventilation air, whereas in b) it is 10 cfm out of 1000 cfm of recirculated and conditioned/filtered air. For the CFIS system, the full amount of expected outside air was still being delivered from a known outdoor intake location, whereas for the Exhaust system of House 1, 34% of the expected outside air was from the vented attic.



**Figure 25. Airflow from Attic to living area zones in House 1, for the Baseline test and four different ventilation systems**

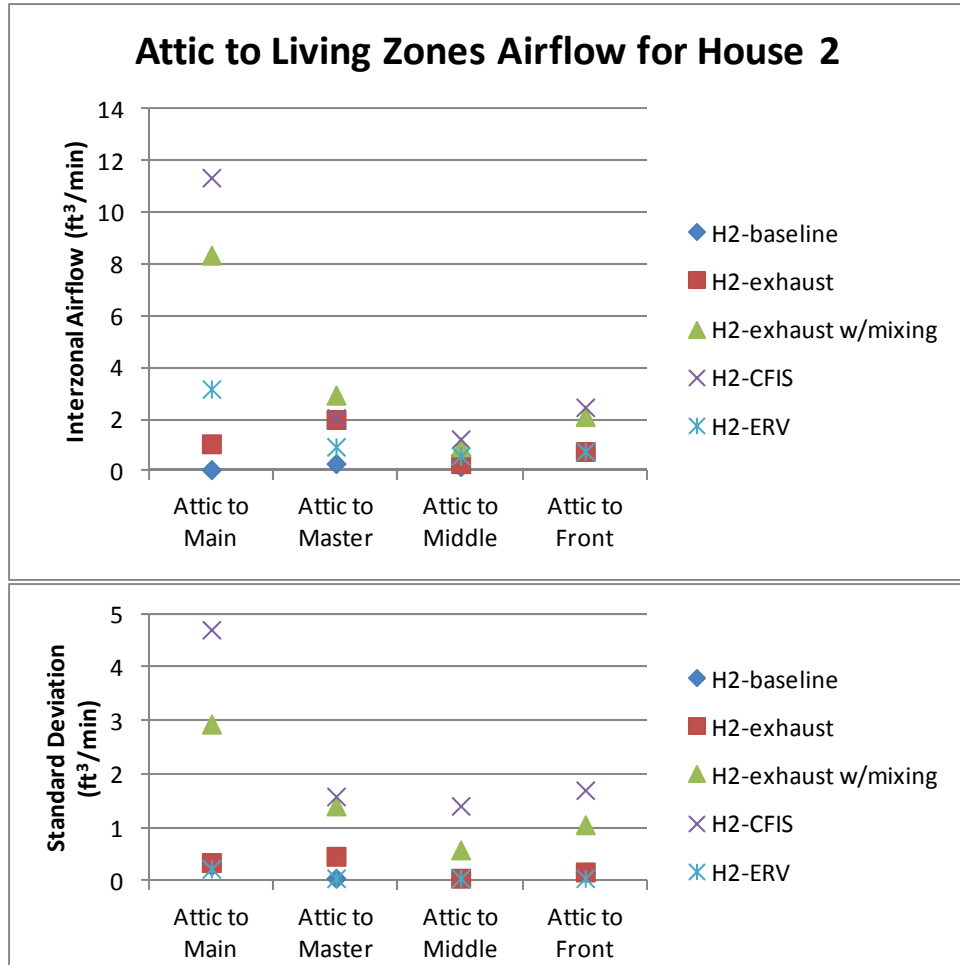

**Figure 26. Airflow from Attic to living area zones in House 2, for the Baseline test and four different ventilation systems**

Figure 27 shows interzonal airflows for a single case — House 2, Test 2 (Exhaust) — where the backup CATS were analyzed as a quality assurance/quality control check on the PFT test and analysis method. There was a strong showing of consistency in results between the two sets of simultaneous samples.

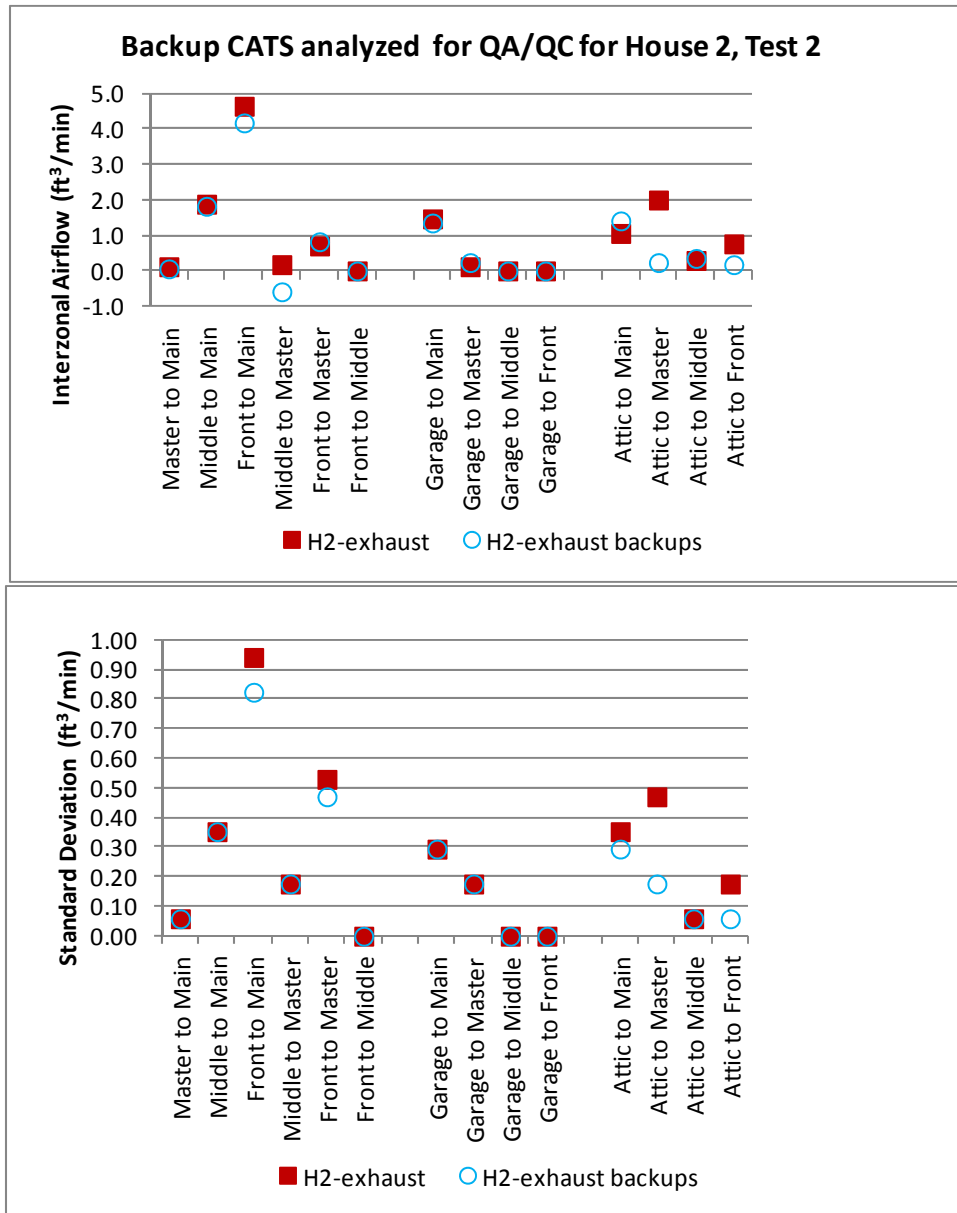

Figure 27. Backup CATS analyzed for QA/QC check; House 2, Test 2 (Exhaust)

Figure 28 through Figure 31 show interzonal airflows for the living space zones in both directions. In terms of internal air distribution, the Baseline system showed little interzonal airflow in all cases. All systems showed little interzonal airflow between bedrooms. As expected with the largest central air distribution system return air inlet in the Main zone, the most interzonal airflow was between the Main zone and bedroom zones for the CFIS and Exhaust with mixing cases. The Exhaust cases showed significant airflow (about 15 cfm) from Main to Master and no airflow in the reverse direction, as expected with the exhaust fan located in the Master zone. Otherwise, the Exhaust systems showed little interzonal airflow and

ventilation air distribution. The ERV system showed little airflow from Main to bedrooms and between bedrooms, but relatively high airflow (10-20 cfm) from bedrooms to Main, as expected since the ERV system supplied fresh air to the bedrooms and exhausted stale air from the Main zone.

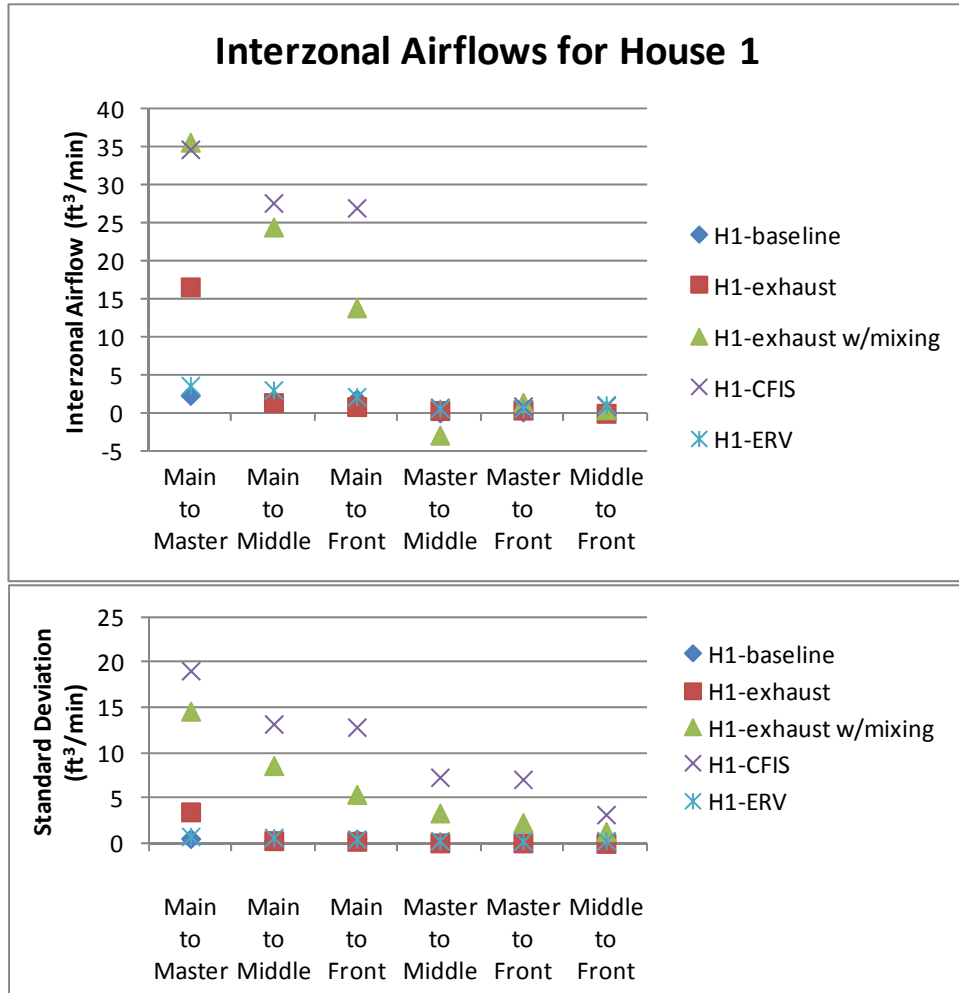

Figure 28. House 1 interzonal airflows for living space zones

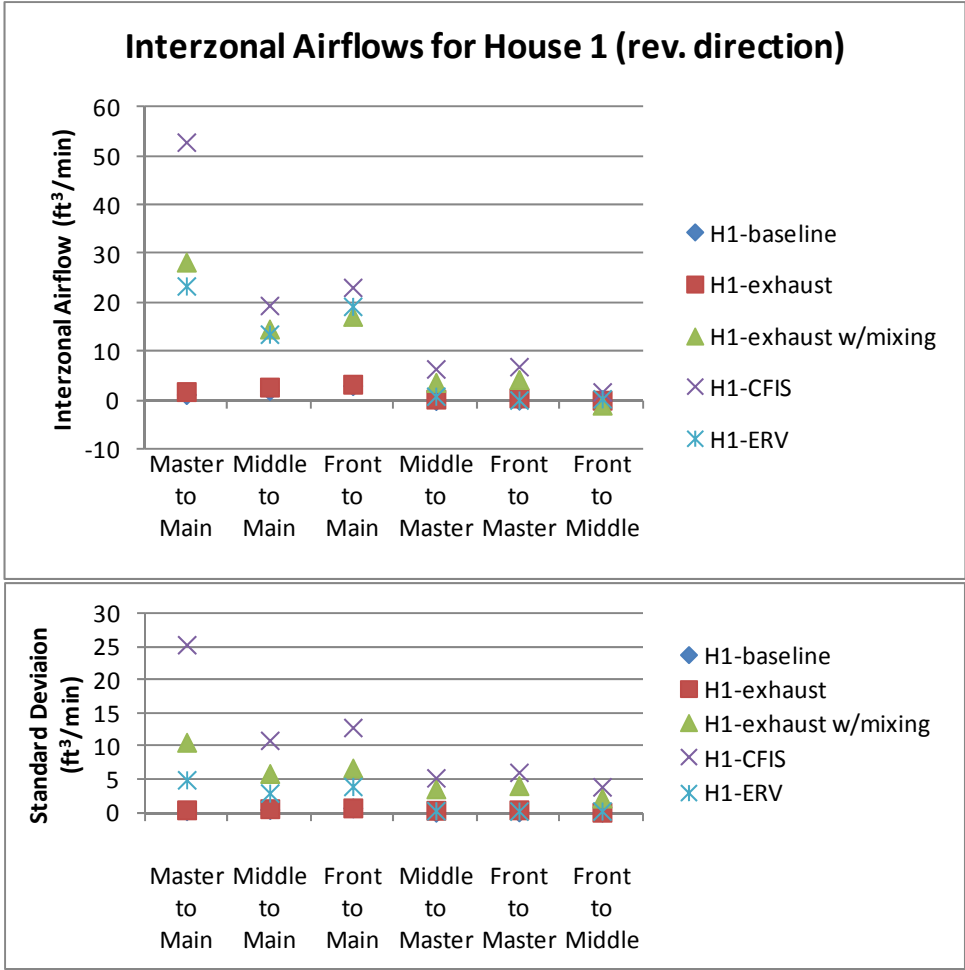

Figure 29. House 1 reverse direction interzonal airflows for living space zones



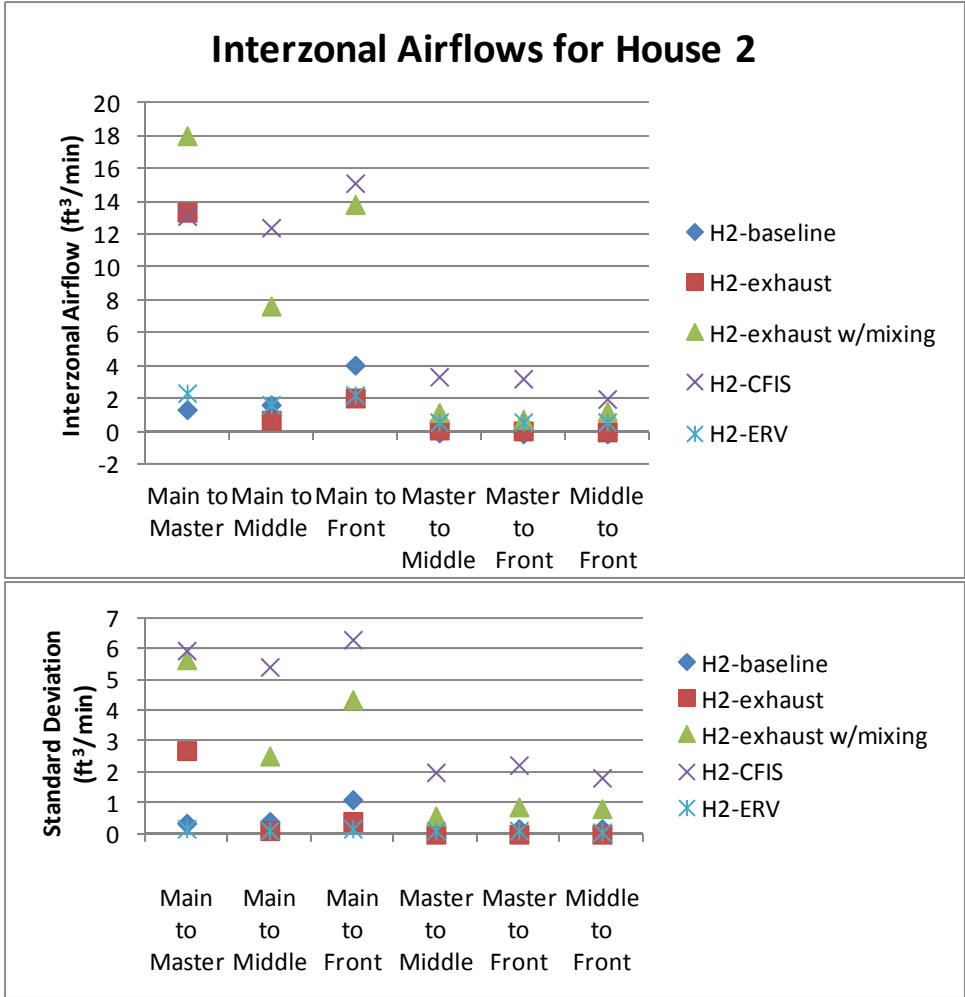

Figure 30. House 2 interzonal airflows for living space zones

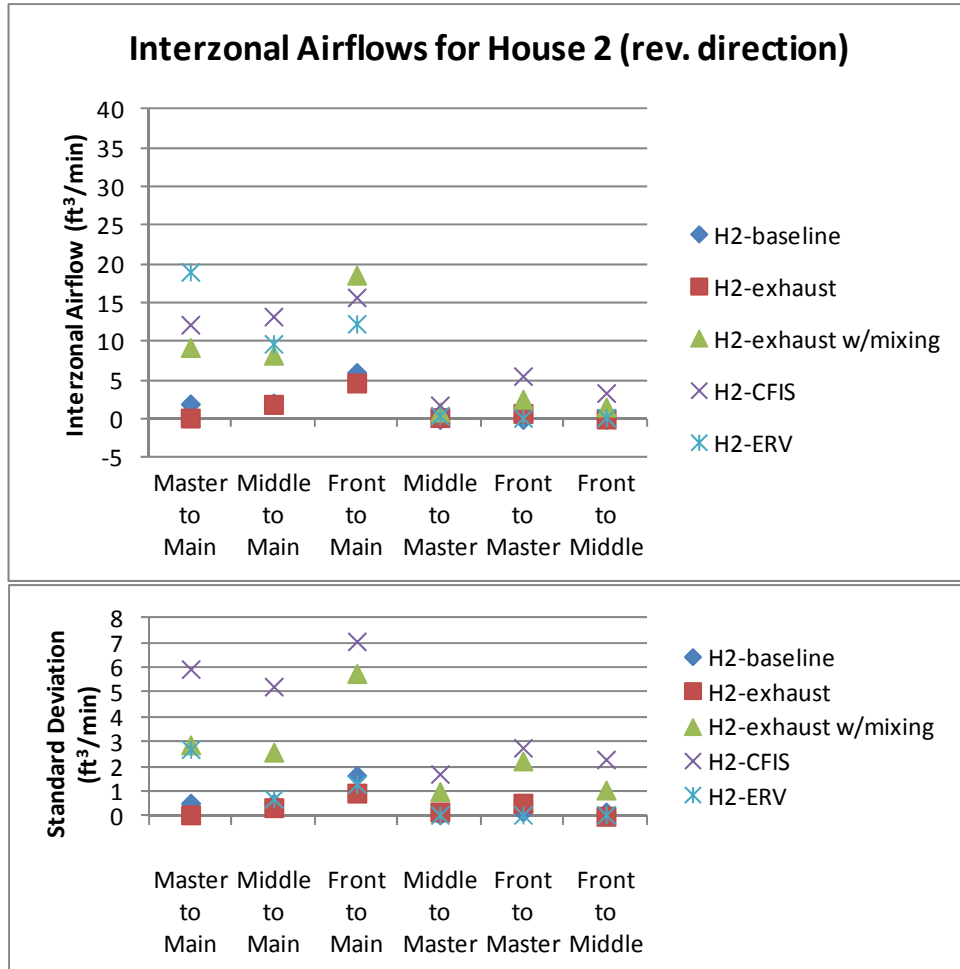

Figure 31. House 2 reverse direction interzonal airflows for living space zones

#### 4.4 Airborne Particulate Sampling

As mentioned above, only the last twenty-one (21) 15 minute particle counting cycles before researchers re-entered the houses, or the last 5.25 hours of the 12 hour sampling period, were used for analysis presentation. This was to isolate the particle load due to the operation of different ventilation system from any occupant (researcher) interaction. Occupant interaction was easy to see in the full set of data, having a large impact on large particles but little impact on the smallest particles.

As mentioned above, particulates were monitored at six particle sizes (0.3, 0.5, 1.0, 2.0, 5.0, 10.0 micrometer) with a Fluke model 985 laser airborne particle counter. The meter has a counting efficiency of 50 % @ 0.3  $\mu\text{m}$  and 100 % for particles > 0.45  $\mu\text{m}$ . The sample flow rate was 0.1 cfm (2.83 L/min). The meter was programmed to complete 48 cycles of 15 minute samples over the second 12-hour period of each test, gathering a sample volume of 1.5  $\text{ft}^3$  (42.45 L) each cycle. Data was recorded electronically and imported into a worksheet for analysis. Only the last twenty-one (21) 15 minute particle counting cycles, or the last 5.25 hours before anyone re-entered the houses were used for analysis. This was to analyze the data closest to steady-state

and to isolate the particle load due to the operation of different ventilation system from any occupant interaction. Occupant interaction was easy to observe in the full set of data, having a large impact on the largest particles but little impact on the smallest particles.

While this report is not intended to address the detailed human health concerns related to particle contaminants, a little background is useful here. Small particles are considered hazardous to human health. Particle sizes of 10 micrometer (micron or  $\mu\text{m}$ ) or less are generally not filtered by the nose and throat and reach the lungs. Particle sizes of 2.5 micrometer and less can enter into the gas exchange region of the lung. Particles sizes of 0.1 micrometer and less can pass through the lung to organs, including the heart and brain.

In rough perspective, bacteria, mold spores, and dust mite allergens can all be 10 micron or less. Cat allergens, tobacco smoke, soot, and smog can all be 1 micron or less. Viruses, tobacco smoke, soot, and smog can all be 0.1 micron or less.

Figure 32 shows plots of the cumulative<sup>10</sup> particle counts for House 1, for all six particle sizes and ventilation systems, for the Main and Master zones side-by-side. Figure 33 shows the same thing for House 2. There was not an important difference in particulate levels between the Main and Master zones, but there was an important and consistent difference found between the ventilation systems. The highest levels were found for the Exhaust system, followed by the Baseline or ERV, followed by the Exhaust with mixing and CFIS. CFIS always showed the lowest particle counts regardless of particle size. As would be expected, this indicated that the Filtrete 700 filters (700 MPR and roughly MERV 9) in the central air distribution system return air grilles were removing a significant amount of particle contaminant 0.3 micron and larger.

---

<sup>10</sup> The cumulative particle count reported throughout this study gives the sum of particles counted that were greater than or equal to threshold particle size given. For example, a cumulative particle count of 1,000 for the 2.0 micron size means that there were 1,000 particles of size greater than or equal to 2.0 micron. Differential particle size can be calculated by subtracting the cumulative particle count of the next larger size from the cumulative particle count of the smaller size. For example, if the cumulative particle count was 1,000 and 10,000 for particle sizes 2.0 micron and 1.0 micron, respectively, then the differential particle count would be 9,000 particles between 1.0 and 2.0 micron size.

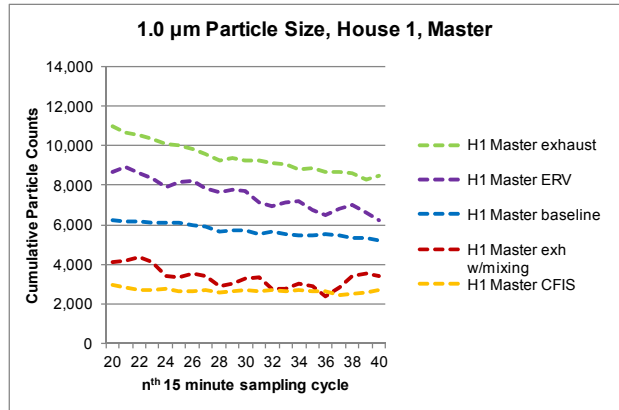
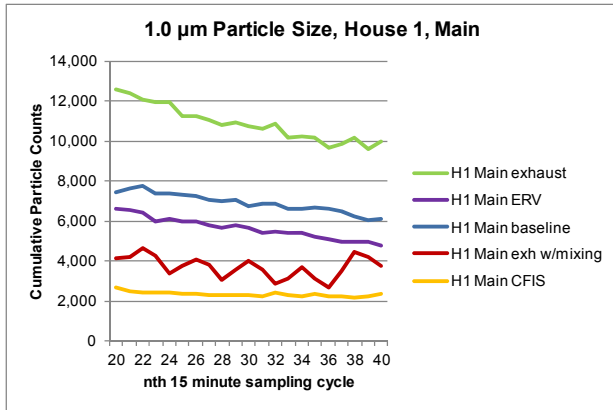
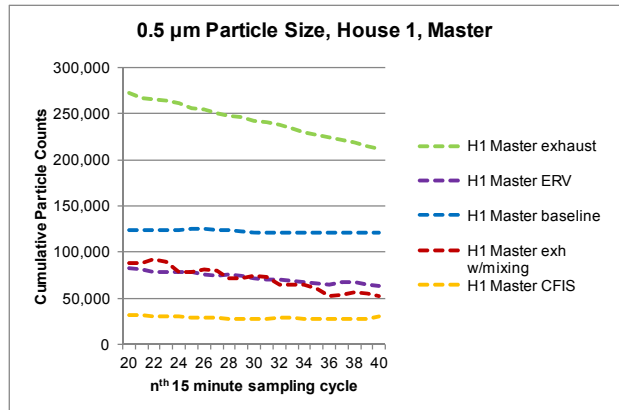
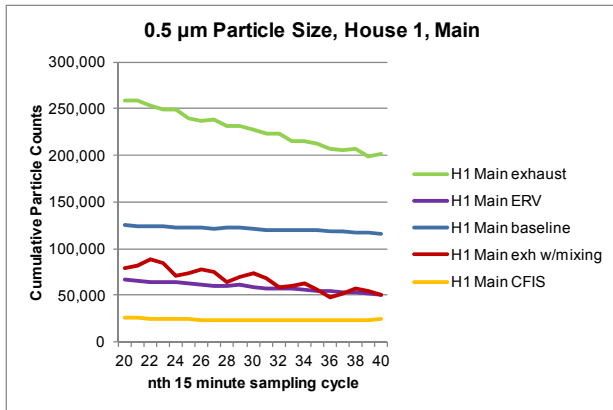
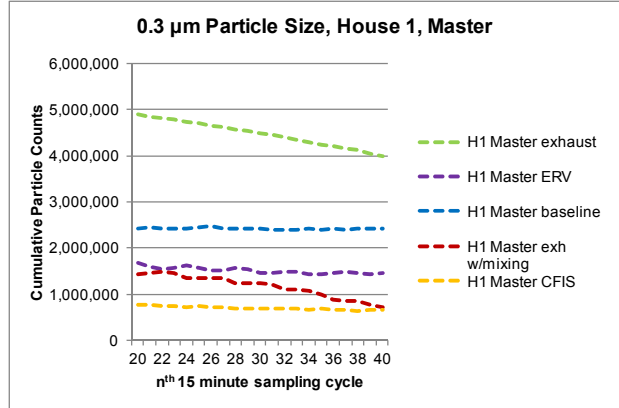
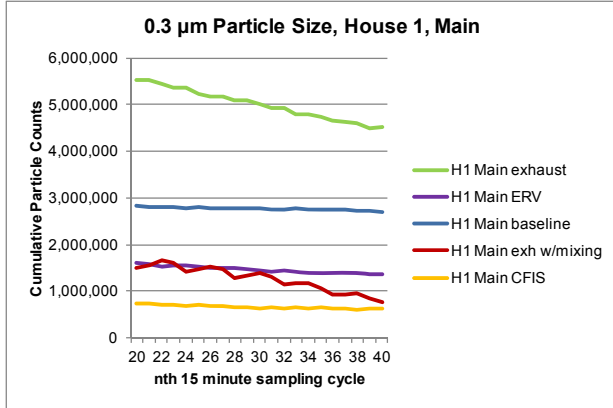

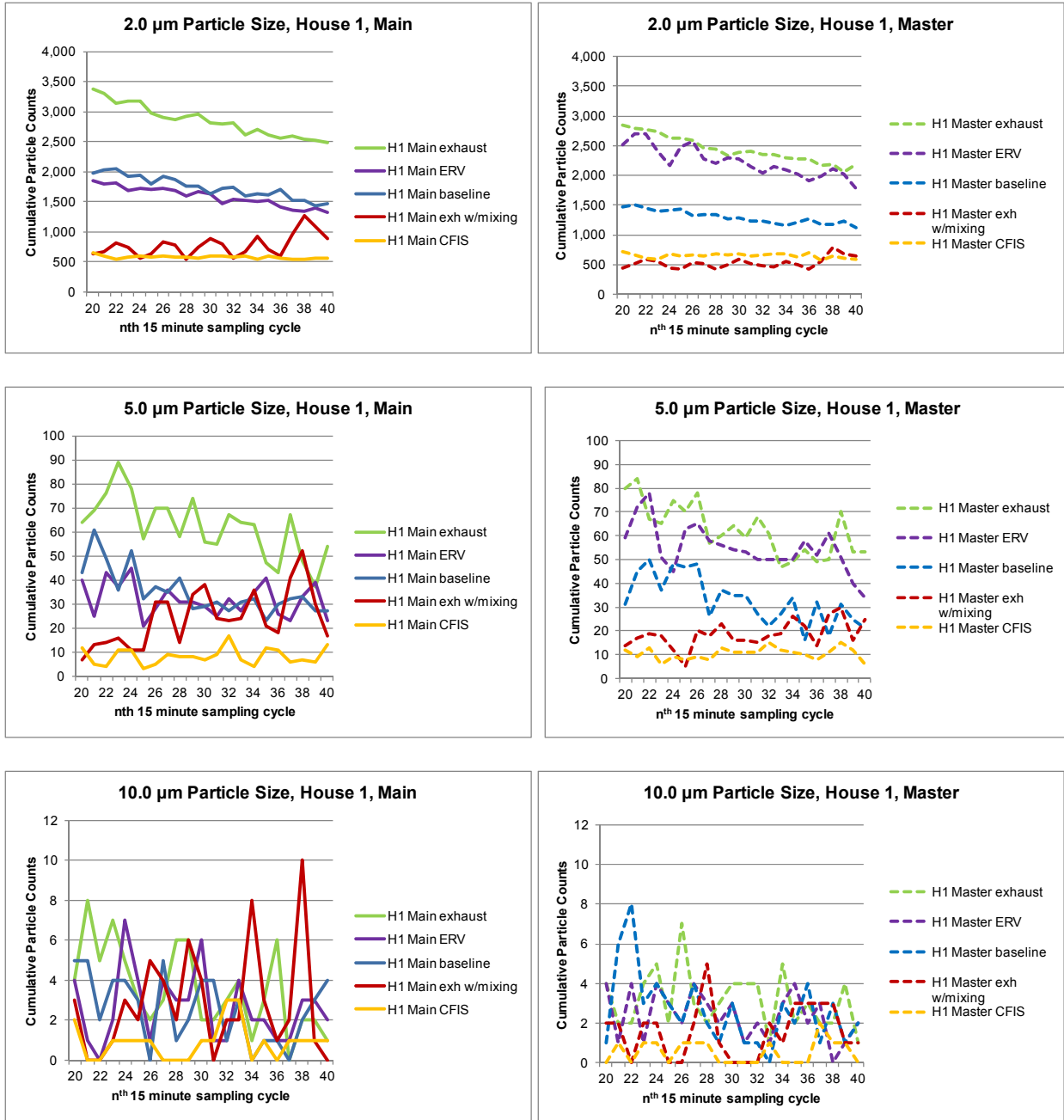

**Figure 32. Cumulative particle counts for six particle sizes (0.3-10 micrometer) for the House1 Main and Master zones**

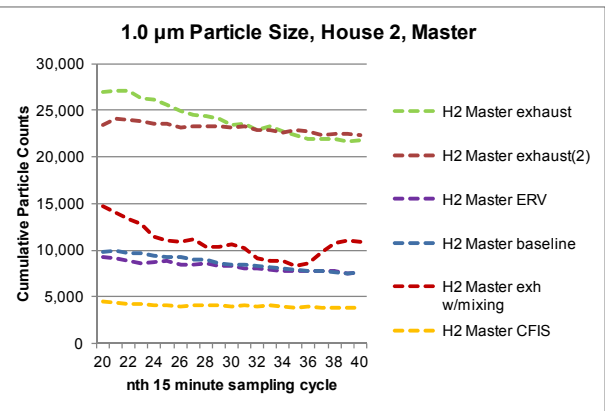
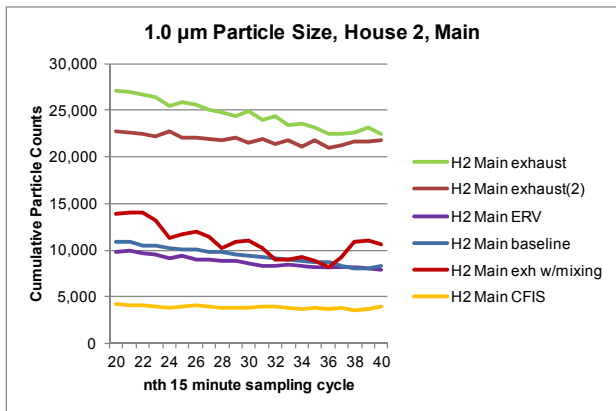
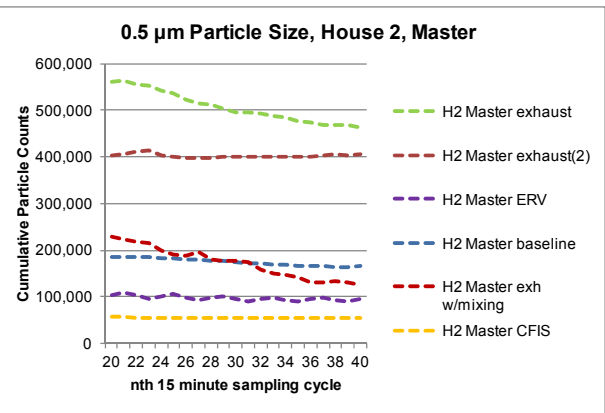
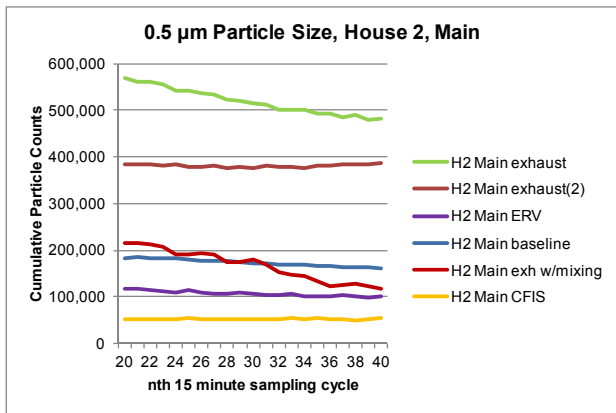
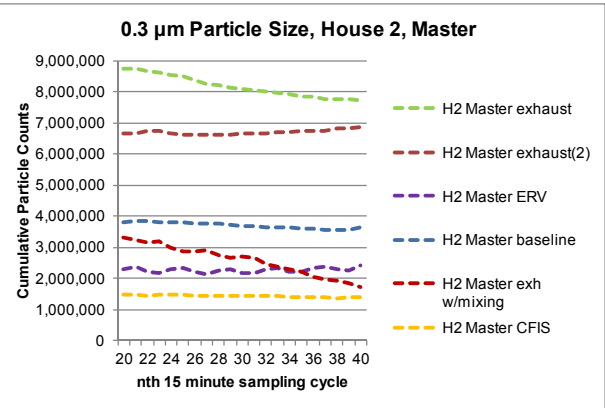
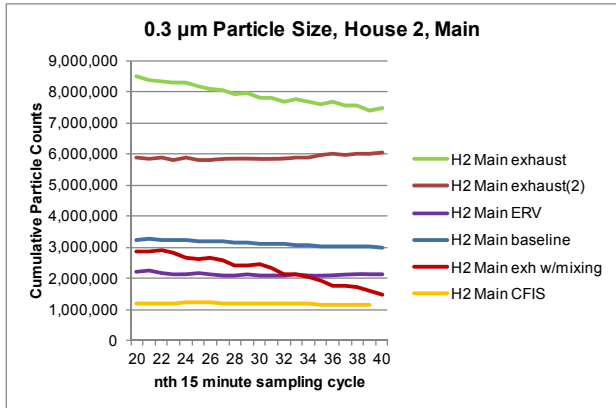

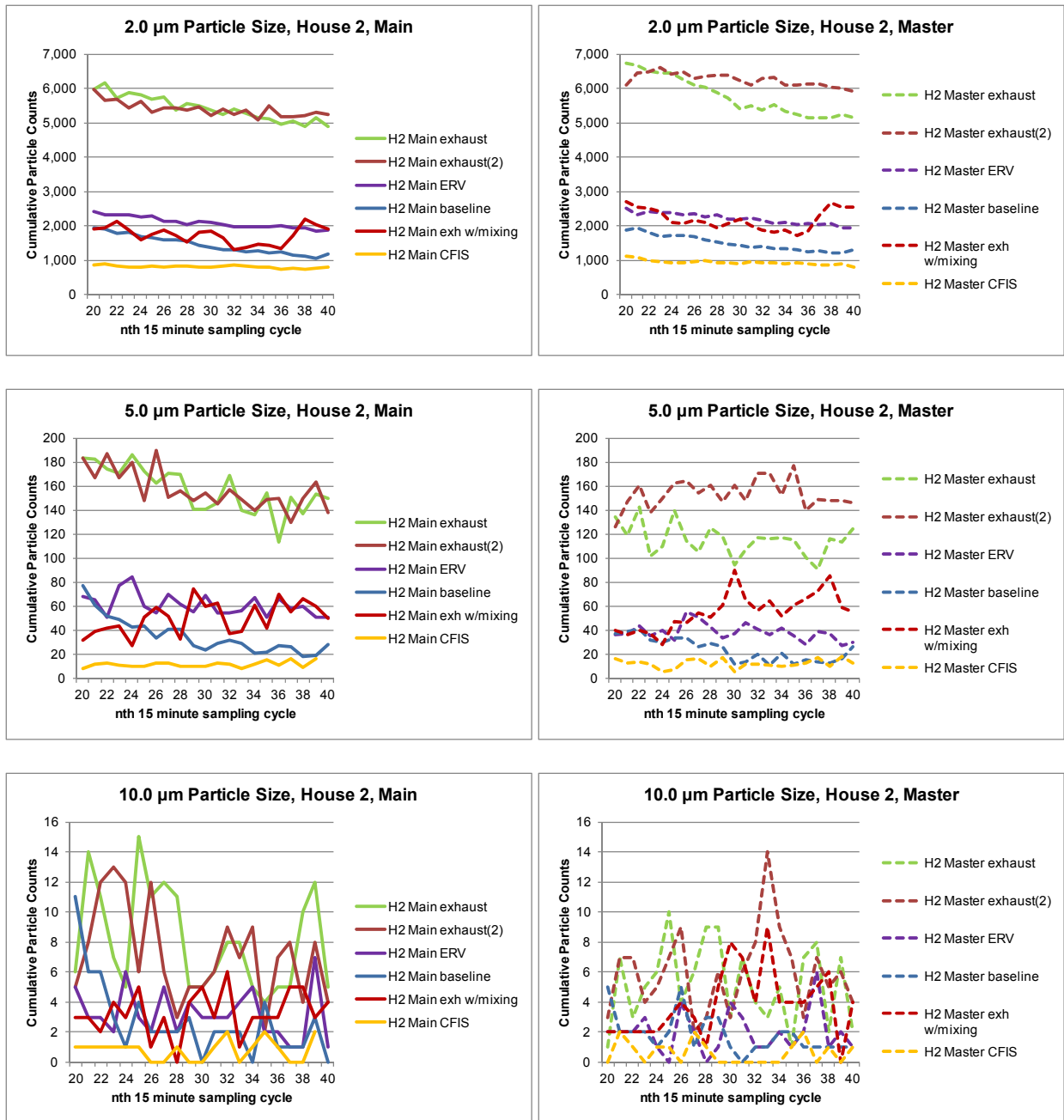

**Figure 33. Cumulative particle counts for six particle sizes (0.3-10 micrometer) for the House 2 Main and Master zones**

Table 9 provides a more detailed analysis of the particle count data. Differential particle counts over the range of 0.3-2.0 micron were calculated from the cumulative particle counts for the Main and Master zones. Then, the percent difference in differential particle counts were shown compared to the Exhaust ventilation system. The average percent difference between the Main and Master zones showed a 69-85% reduction in small particles over the Exhaust-only system in House 1, and a 44-73% reduction in House 2. The CFIS ventilation system showed the greatest reduction in small particles for both houses, attributable to recirculation air filtration by operation of the central air distribution system.

**Table 9. Calculation of differential particle counts over the range of 0.3-2.0 micron; the percent difference in differential counts are shown compared to the Exhaust ventilation system**

Test #	Ventilation System	Main zone				Master zone				Average % diff.
		Cumulative Counts <sup>1</sup> at 0.3 μm	Cumulative Counts <sup>1</sup> at 2.0 μm	Differential Counts 0.3- 2.0 μm	% diff. from Exhaust	Cumulative Counts <sup>1</sup> at 0.3 μm	Cumulative Counts <sup>1</sup> at 2.0 μm	Differential Counts 0.3- 2.0 μm	% diff. from Exhaust	
<b>House 1</b>										
1	Baseline	2,764,437	2,992	2,761,446	-47%	2,453,086	1,871	2,451,215	-47%	-47%
2	Exhaust	5,223,259	3,917	5,219,341	--	4,654,361	3,087	4,651,275	--	--
3	Exhaust w/mixing	1,407,415	1,557	1,405,858	-73%	1,299,948	1,066	1,298,882	-72%	-73%
4	CFIS	730,706	1,209	729,497	-86%	774,120	942	773,178	-83%	-85%
5	ERV	1,522,578	2,120	1,520,458	-71%	1,572,288	2,652	1,569,636	-66%	-69%
<b>House 2</b>										
1(6)	Baseline	3,171,002	2,611	3,168,391	-39%	3,745,584	2,061	3,743,523	-20%	-29%
2	Exhaust	8,009,169	7,086	8,002,084	--	8,279,091	7,795	8,271,296	--	--
3	Exhaust w/mixing	2,582,948	4,536	2,578,411	-51%	2,887,309	4,900	2,882,409	-38%	-44%
4	CFIS	1,221,080	2,258	1,218,822	-77%	1,445,509	2,130	1,443,379	-69%	-73%
5	ERV	2,277,061	2,882	2,274,178	-56%	2,396,952	2,935	2,394,018	-49%	-52%

<sup>1</sup> Cumulative counts per 15-minute sample, averaged over 21 samples starting at hour 16.75 and ending at hour 22 of each 24 hour test period

Particulate measurements in the Attics and Garages are shown in Figure 34. For House 1, the measurements were taken during in the Attic during the ERV test, and in the Garage during the CFIS test. For House 2, the measurements were taken in the Attic and the Garage during two different Baseline tests. The levels of particulate were reasonably close between the Attic and Garage of each individual house. House 1 had somewhat lower particulate levels than House 2 in the smallest particle sizes, they were nearly the same for the 1.0 micron size, then House 2 had lower levels in the 2.0 micron size and larger. The Attic and Garage in both houses had somewhat lower particulate levels than outside (Figure 35), particularly in the larger particle sizes.

The two outside tests were made outside of House 2 during two Baseline tests. The second Baseline test was made for House 2 because of inadvertent exhaust fan usage during the first Baseline test. Indoor and outdoor temperature and relative humidity were similar during both tests. Wind speed was a little higher during the second test but the outside sample location was somewhat sheltered from wind. The particle count results of the two outside tests show remarkable consistency in Figure 35 and Table 11, indicating good measurement repeatability. We did not have enough meters to measure outdoor particulate for each test, however, the measurements from these two tests, bracketing the entire testing period, were consistent with each other and essentially unchanging for 12 hours at a time. There were no obvious sources nearby in this suburban location, or weather disturbances that would give particular reason to believe that outdoor particulate conditions would have changed much between test day 1 and test day 6 any more than they did on test day 1 and test day 6.



**Table 10. Cumulative and differential particle counts measured outdoors during baseline tests on the first and last test days**

Test #	Ventilation System	Outside		
		Cumulative Counts <sup>1</sup> at 0.3 µm	Cumulative Counts <sup>1</sup> at 2.0 µm	Differential Counts 0.3- 2.0 µm
1	Baseline	4,995,436	24,710	4,970,725
1(6)	Baseline	4,432,017	13,569	4,418,448

Figure 36 shows the particle count measurements during the second Baseline test, comparing the coincident outside and inside results for the Main and Master zones, respectively. In both cases, the inside and outside particle counts are nearly the same for the 0.3 and 0.5 micron particle sizes. For 1.0 micron particles, the inside counts were about 5 times lower than outside. That trend increased progressively to about 100 times lower for inside counts compared to outside counts at the 10.0 micron size.

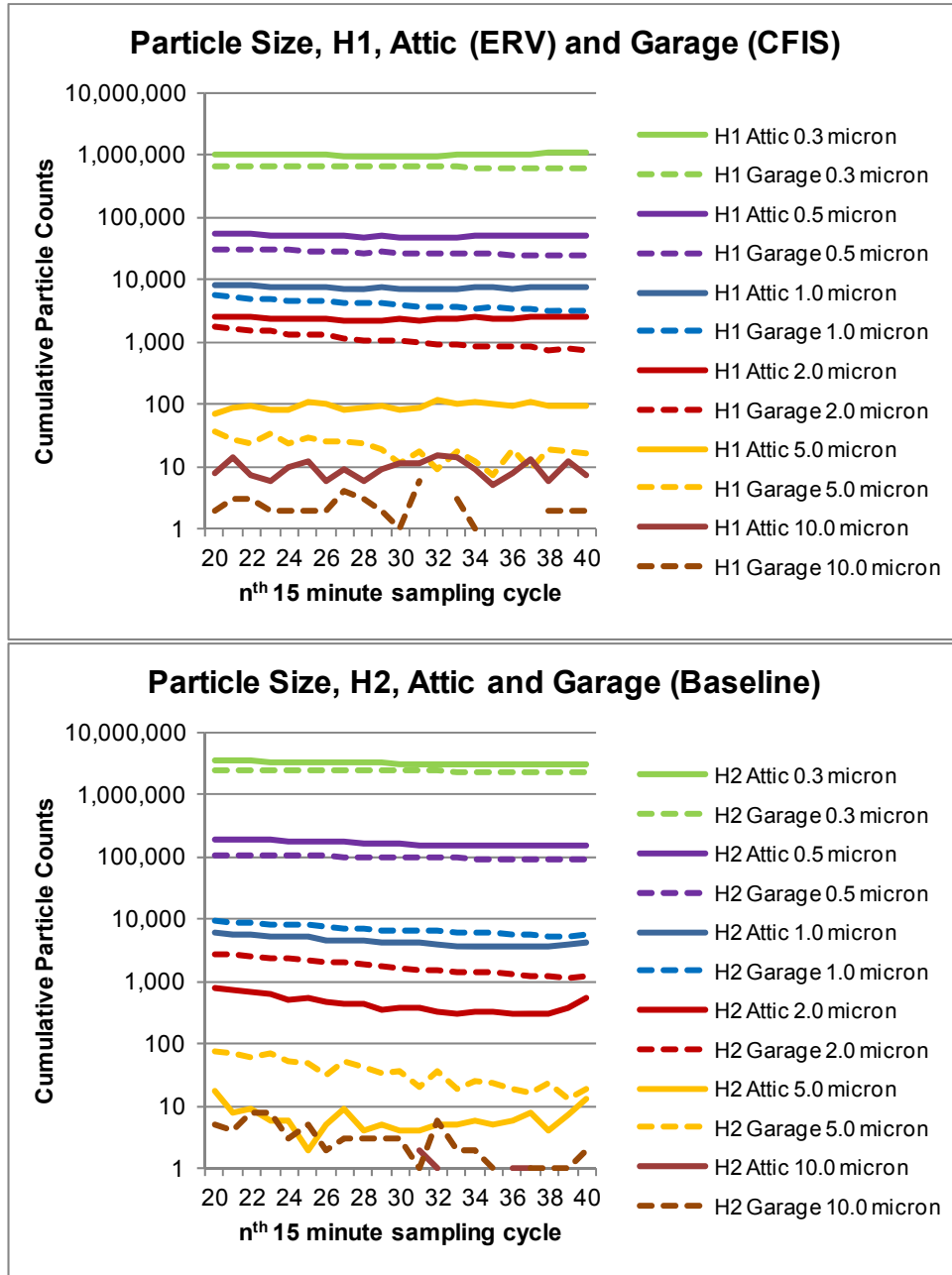

Figure 34. Cumulative particle counts for six particle sizes (0.3-10 micrometer) for the Attic and Garage zones for House 1 and House 2

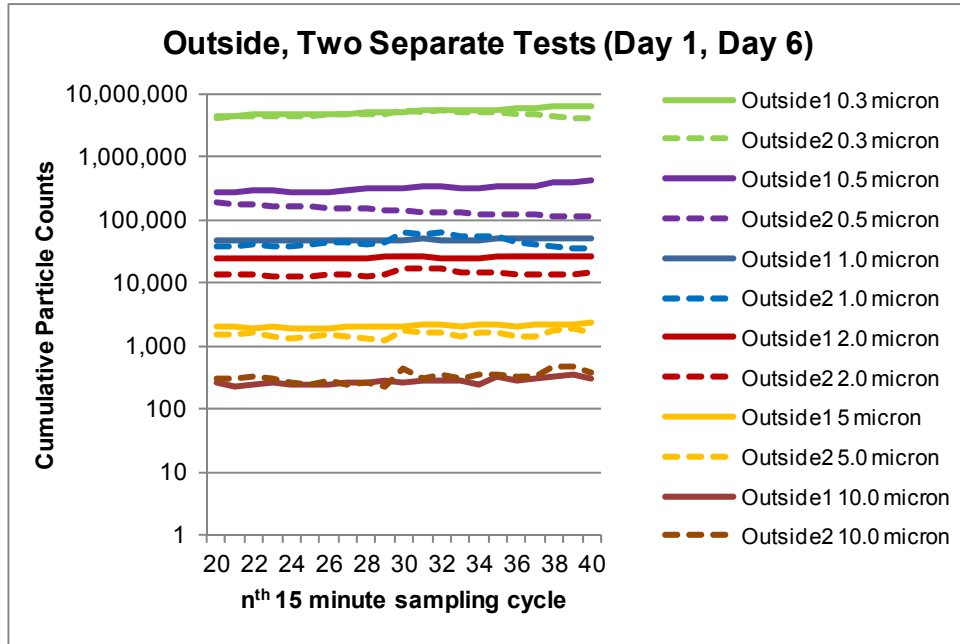

Figure 35. Cumulative particle counts for six particle sizes (0.3-10 micrometer) sampled outside on the first and last test days (test day 1 and test day 6)

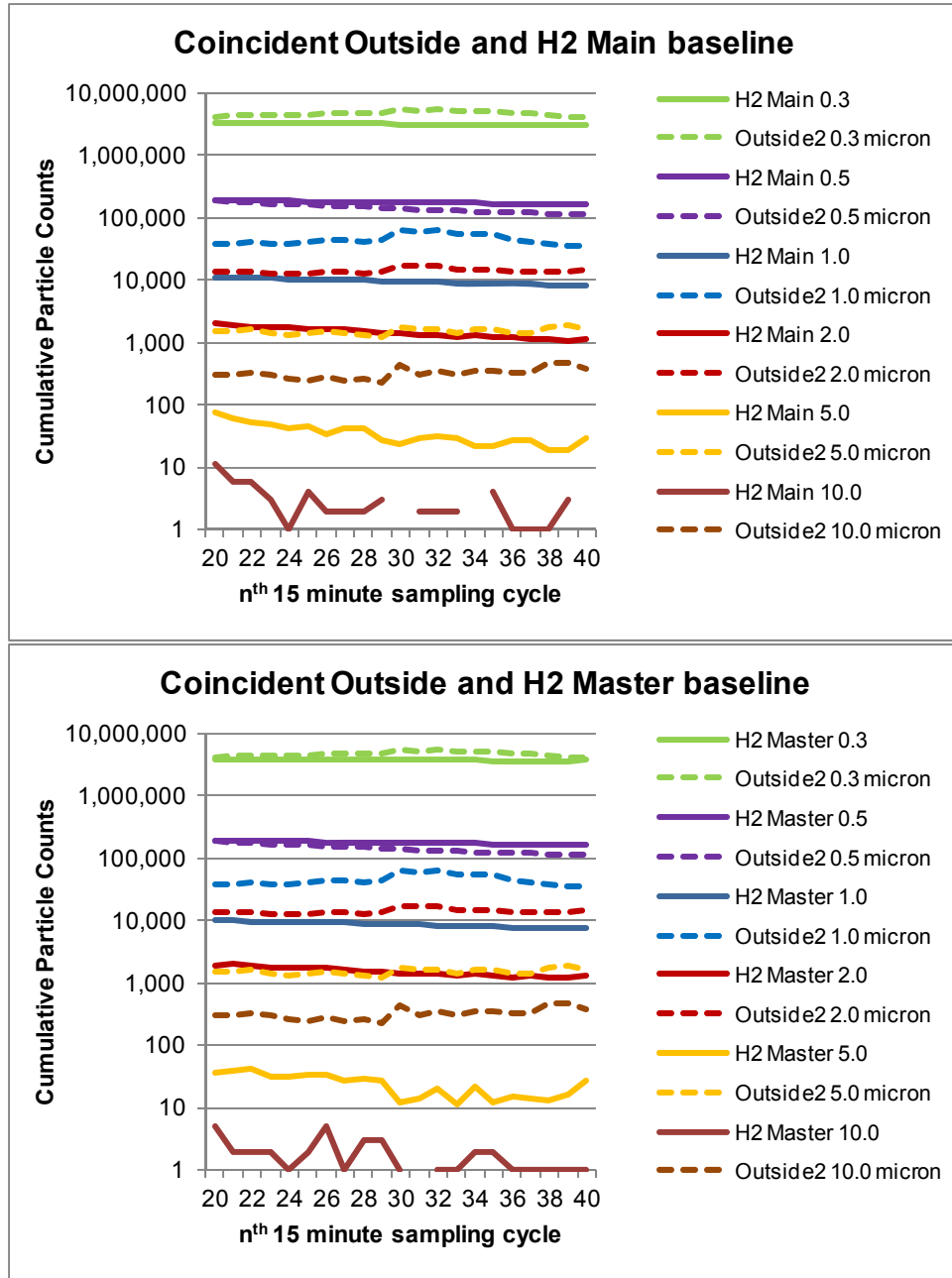

Figure 36. Cumulative particle counts for six particle sizes (0.3-10.0 micron) for simultaneous measurements made outside and inside during the H2 Baseline test

#### 4.5 Formaldehyde Sampling

Formaldehyde was sampled in the Main and Master zones in the last hour of each 24 hour test period. Table 11 provides the numerical results and Figure 37 graphically illustrates the relative concentrations during the Baseline test and the four ventilation system tests. Outside formaldehyde concentration was not measured at this location, but can generally be taken to be 2-3 ppb (2.5-3.7  $\mu\text{g}/\text{m}^3$ ) for this region of Texas (EPA 1991).

In House 1, all ventilation systems reduced the formaldehyde concentration over the indoor Baseline concentration which was roughly 20 times higher than what would be expected outdoors. Exhaust-only ventilation reduced the indoor formaldehyde concentration the least, followed by Exhaust with mixing, CFIS, and ERV. Exhaust with mixing likely reduced the concentration over Exhaust-only because Exhaust-only interacted more with the Main and Master zones than with the Front and Middle bedroom zones. Whole-house mixing averaged conditions such that concentrations in the Main and Master zones were lower.

In House 2, the Exhaust systems either increased or did not appreciably change the formaldehyde concentration in the Main and Master zones. The CFIS and ERV systems showed a significant reduction in formaldehyde concentration over the Baseline, and Exhaust tests. In general for both houses, the CFIS and ERV systems showed a 60% to 70% reduction in formaldehyde concentration over Exhaust.

**Table 11. Formaldehyde concentrations in House 1 and House 2, for the Baseline test and four different ventilation systems**

Description	HCHO Concentration	
	ug/m <sup>3</sup>	ppb
H1 baseline main	68	56
H1 baseline master	71	58
H1 exhaust main	51	42
H1 exhaust master	53	44
H1 exh w/mixing main	42	34
H1 exh w/mixing master	40	33
H1 CFIS main	19	15
H1 CFIS master	17	14
H1 ERV main	16	13
H1 ERV master	11	9
H1 exh w/mixing attic	9	8
H1 exh w/mixing garage	25	21
H2 baseline main	40	33
H2 baseline master	23	19
H2 exhaust main	39	32
H2 exhaust master	37	30
H2 exh w/mixing main	36	29
H2 exh w/mixing master	32	26
H2 CFIS main	22	18
H2 CFIS master	20	16
H2 ERV main	17	14
H2 ERV master	11	9
H2 exh w/mixing attic	23	18
H2 exh w/mixing garage	35	29

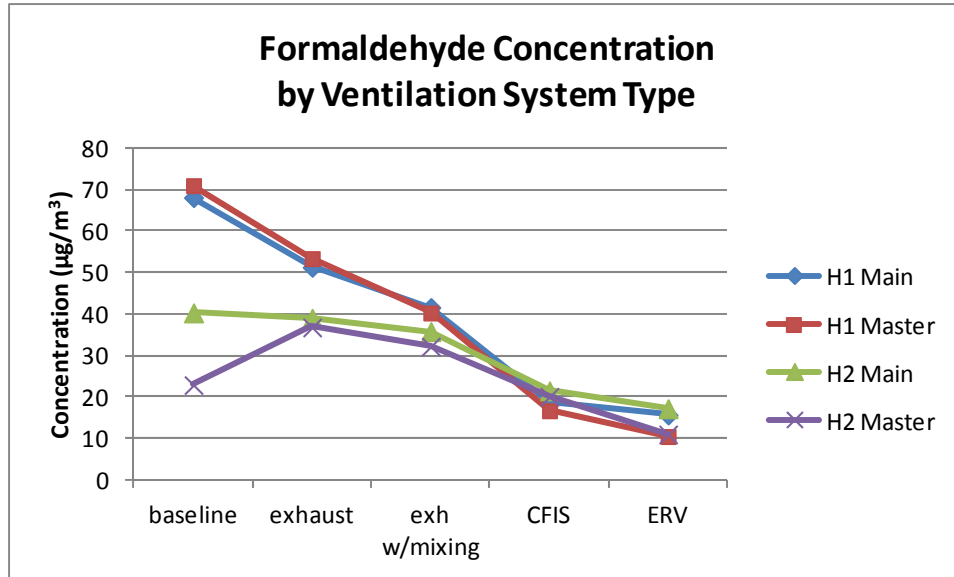

Figure 37. Formaldehyde concentration measured in the Main and Master zones of House 1 and House 2 during the Baseline test and four ventilation system tests

As shown in Figure 38, formaldehyde concentration was measured in the vented attic of House 1 and the unvented attic of House 2, as well as both garages during the Exhaust with mixing test. This was a period with somewhat higher wind than for the other test periods (4-8 mph vs. 0-2 mph) as shown in Figure 13. The vented attic concentration was about 3 times higher than what would be expected for outdoors, while the unvented attic was about 8 times higher. The garages of House 1 and House 2 showed 25 µg/m<sup>3</sup> and 35 µg/m<sup>3</sup>, respectively.

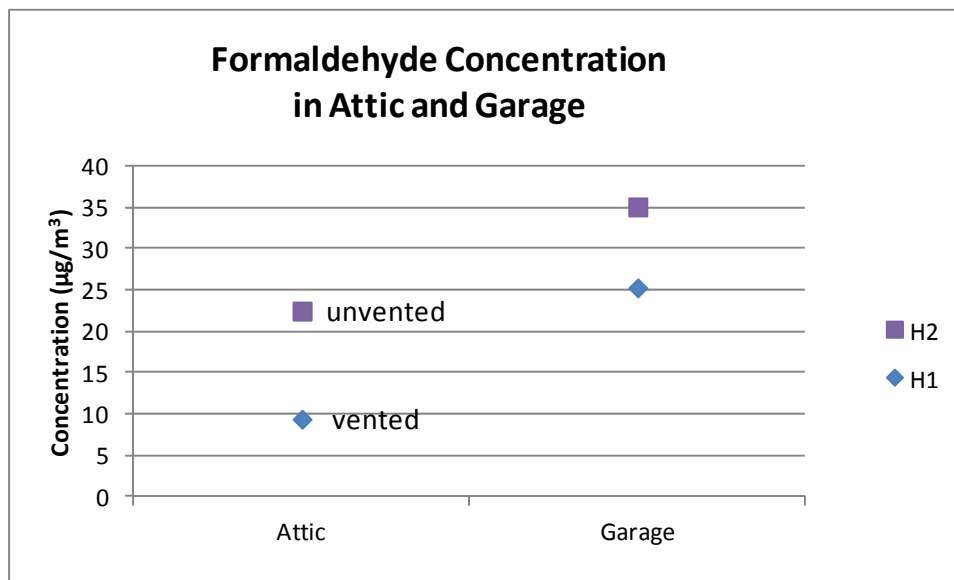

Figure 38. Attic and garage formaldehyde concentrations for both houses

## 4.6 Volatile Organic Compound Sampling

Sampling for Volatile Organic Compounds was done during the last 1.5 hour of each 24 hour test period. Concentrations of the Top 20 VOCs were reported by the testing lab. The top half of those are shown in Figure 39 through Figure 42. The trend was that the Baseline test showed the highest VOC concentrations, followed by the Exhaust and Exhaust with mixing ventilation systems, then the CFIS and ERV ventilation systems. In a few cases the order was different, and in some cases the results for all systems were relatively close to each other.

A full list of the functional descriptions of the VOCs found in the living zones, attics, and garages is given in Appendix A. The highest concentrations found in House 1 were for Xylene and Benzene, solvents used in sealing the decoratively stained concrete floors throughout both houses. In House 2, a floor sealer was used that was designed to be lower-emitting than the sealer used in House 1, and it apparently worked as advertised. House 2 also used a special gypsum board reported to absorb VOCs. Two of the top three compounds found in the House 2 unvented attic were related to the foam insulation used in the walls and unvented attic. Besides the Xylene, Benzene, and Toluene solvents used in finishing the stained concrete floors in House 1, the predominant compounds found in both houses were:

- Pinene - used as a fragrance chemical

- Limonene - used in flavor, fragrance, cosmetics, and cleaning products

- Hexanal - used in flavor products

- Carene - used in flavor and fragrance products; occurs naturally in turpentine, rosemary, cedar, pine

- Phellandrene - used in fragrances.

Some of the same compounds found in this study were also found in a prior study by Hodgson et al. 2000, where in both manufactured and site-built houses, the predominant airborne compounds were  $\alpha$ -pinene, formaldehyde, hexanal, and acetic acid.

Objectionable odor thresholds for the variety of VOCs measured in this study, many of which were found to be intentional fragrance or flavor products, are unknown. That was not a goal of this study. However, people generally know by experience about objectionable odors due to general living activities, often just called "stuffiness." While even in that case constituent chemical odor thresholds are not known, surrogate thresholds have been found to make sense, such as tracking and adjusting ventilation to CO<sub>2</sub> levels when people are the predominant source of the odor. Controlling ventilation to avoid the "stuffiness" odor complaint is a practical objective in building management. The metric of annual average relative dose of any chemical contaminant is meaningless to this objective because the time scale is completely inappropriate. For general odor control, a ventilation time scale of a few hours is appropriate. After proper local exhaust of concentrated sources, dilution of indoor odors by full distribution of ventilation air, and recirculation mixing to homogenize larger low concentration areas with smaller high concentration areas, is a practical and reasonable approach to indoor air odor control.

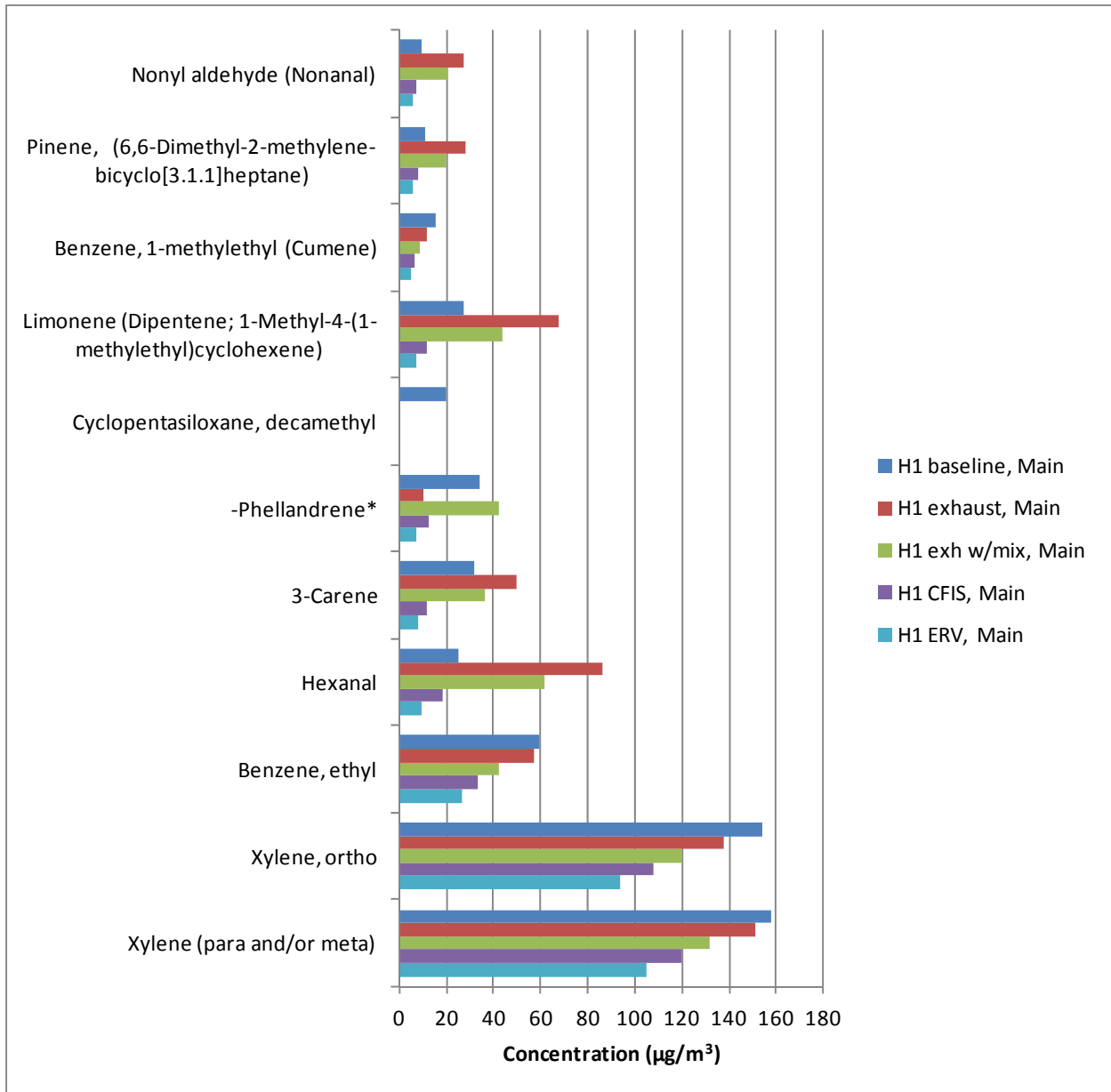

**Figure 39. Concentrations of the Top 11 volatile organic compounds found in the Main zone of House 1, for the Baseline test and four different ventilation systems**



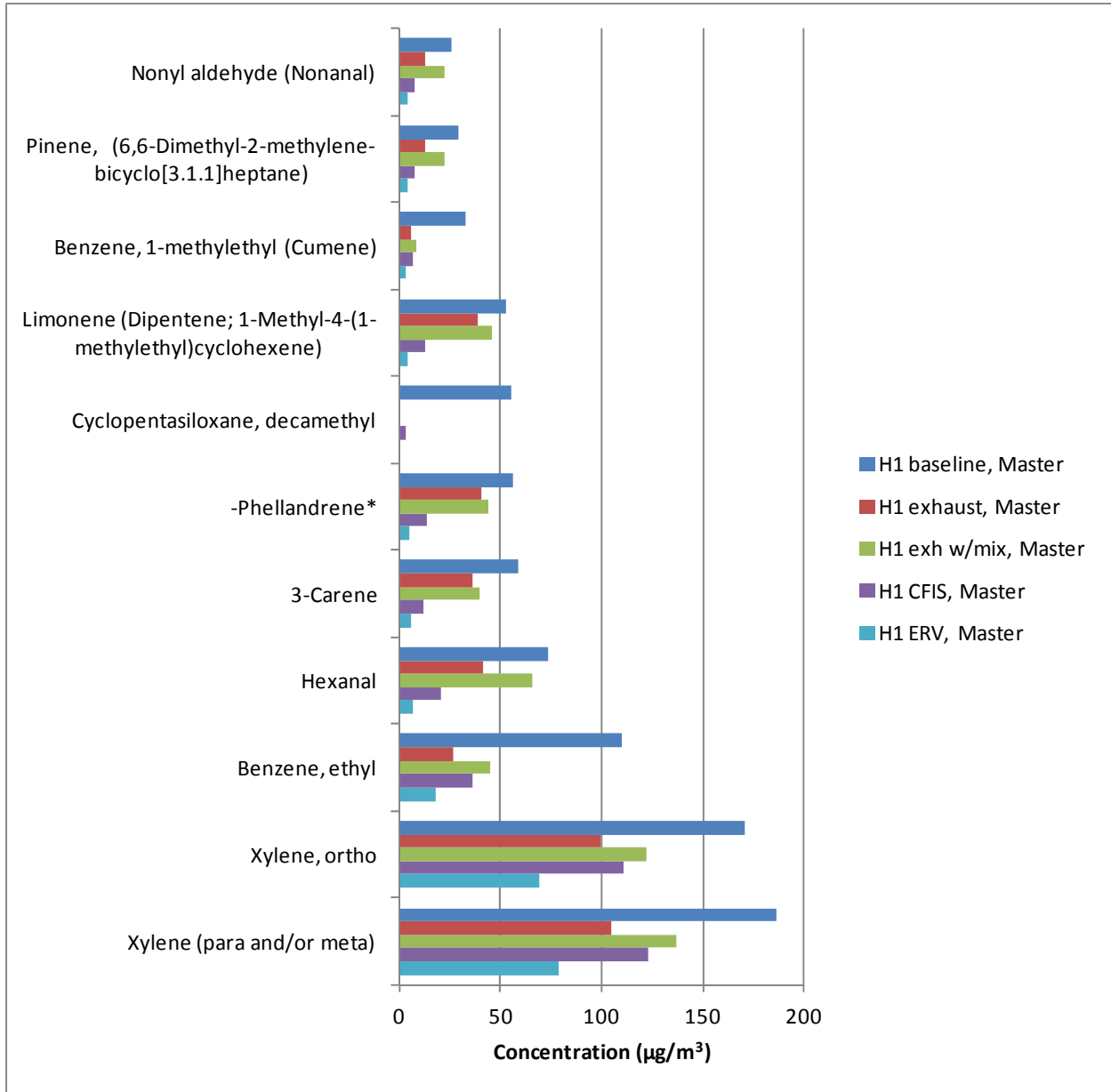
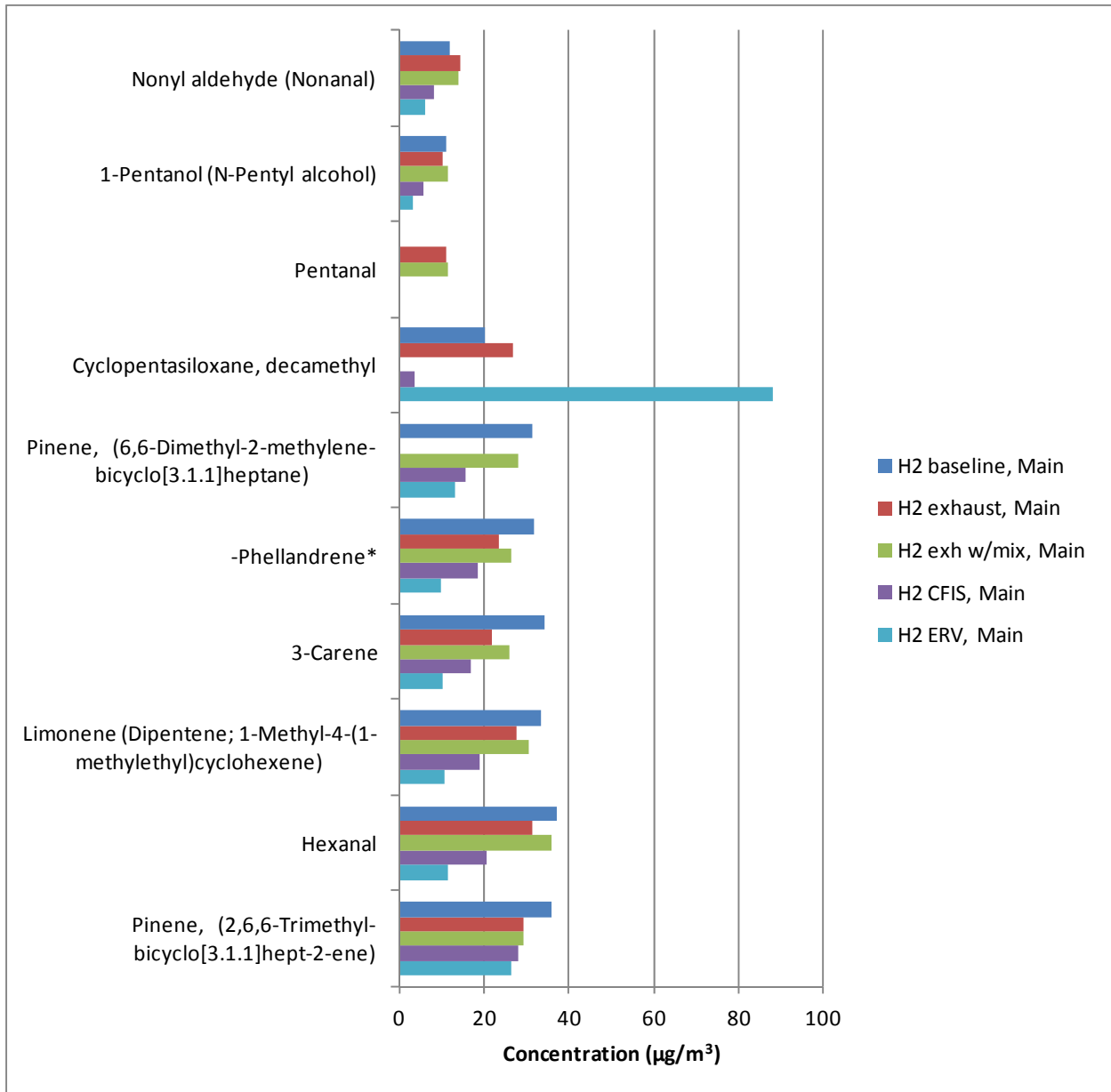
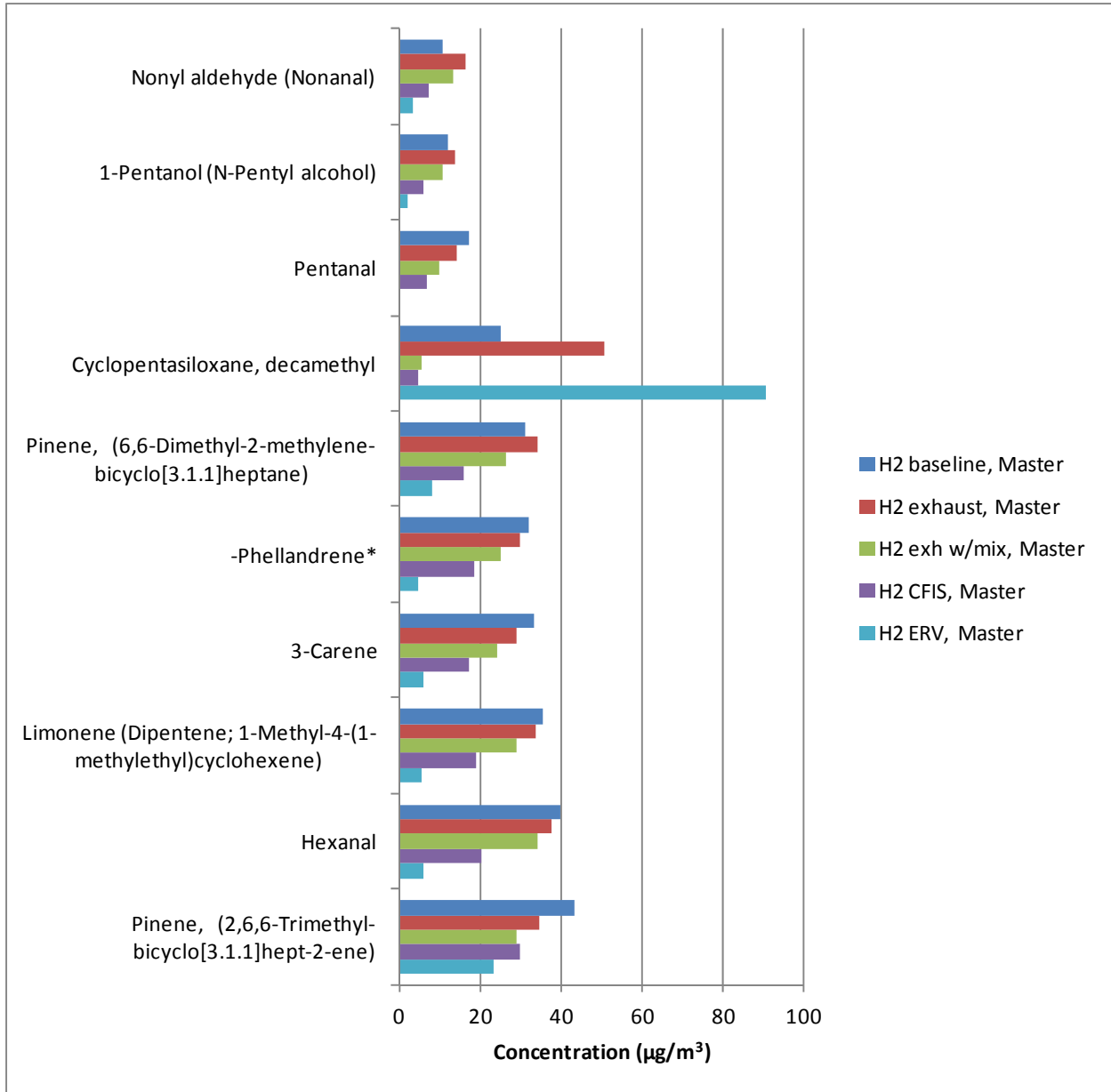

Figure 40. Concentrations of the Top 11 volatile organic compounds found in the Master zone of House 1, for the Baseline test and four different ventilation systems



**Figure 41. Concentrations of the Top 10 volatile organic compounds found in the Main zone of House 2, for the Baseline test and four different ventilation systems**



**Figure 42. Concentrations of the Top 10 volatile organic compounds found in House 2 Master zone, for the Baseline test and four different ventilation systems**

Table 14 shows the VOC concentrations measured in the attic of both houses and provides a description of the typical functional use of each compound, as researched on the internet. Once again, the solvents used in finishing the decorative concrete floors in the living space show up in the House 1 attic. The balance of compounds were mostly seemingly harmless fragrance and flavor products. Figure 43 shows the data from Table 14 in graphical form.

Total Volatile Compound (TVOC) measurements are reported in Table 12 by House, zone, and ventilation system. The TVOC data showed that, compared to the Exhaust system, the CFIS and ERV ventilation systems reduced total volatile organic compounds (TVOC) by 47% and 57%, respectively, averaged between the two houses. Compared to the Baseline tests, the Exhaust system increased TVOC by 37% in the House 1 Main zone, and increased TVOC by 18% in the House 2 Master zone. This highlights that the unknown air path, or source of outside air, for the Exhaust ventilation system can cause indoor air to be more contaminated depending on what contaminants are picked up on the way in.

**Table 12. Total Volatile Compounds (TVOC) by House, zone, and ventilation system**

Test #	Ventilation System	Main zone		Master zone		Average % diff.
		TVOC $\mu\text{g}/\text{m}^3$	% diff. from Exhaust	TVOC $\mu\text{g}/\text{m}^3$	% diff. from Exhaust	
<b>House 1</b>						
1	Baseline	690	-37%	1,310	123%	43%
2	Exhaust	1100	--	588	--	--
3	Exhaust w/mixing	820	-25%	865	47%	11%
4	CFIS	459	-58%	458	-22%	-40%
5	ERV	357	-68%	271	-54%	-61%
<b>House 2</b>						
1(6)	Baseline	519	6%	511	-18%	-6%
2	Exhaust	491	--	622	--	--
3	Exhaust w/mixing	477	-3%	438	-30%	-16%
4	CFIS	264	-46%	252	-59%	-53%
5	ERV	295	-40%	209	-66%	-53%
<b>Combined</b>						
1	Baseline					18%
2	Exhaust					--
3	Exhaust w/mixing					-3%
4	CFIS					-47%
5	ERV					-57%

TVOC measurements in the Attic and Garage zones of both houses were taken at the same time during the Exhaust with mixing test. These values are shown in Table 13. The TVOC measurement in the unvented attic of House 2 was slightly higher than the Baseline test measurements in the Main and Master zones, and, as expected, the unvented attic of House 2 showed higher TVOC than the vented attic of House 1. Neither of the garages had any vehicles

or equipment with engines or fuel. The House 1 garage housed an atypical series of large batteries.

**Table 13. TVOC measurements in the Attic and Garage zones of both houses**

		<b>Attic</b>	<b>Garage</b>
<b>Test #</b>	<b>Ventilation System</b>	<b>TVOC <math>\mu\text{g}/\text{m}^3</math></b>	<b>TVOC <math>\mu\text{g}/\text{m}^3</math></b>
<b>House 1</b>			
3	Exhaust w/mixing	200	302
<b>House 2</b>			
3	Exhaust w/mixing	602	132

Table 15 shows the VOC concentrations measured in the garages of both houses. Once again, the compounds with the highest concentrations were found to be used in flavor, fragrance, cosmetics, and cleaning products. Figure 44 shows the data from Table 15 in graphical form.

**Table 14. VOCs found in both attics, sorted by high to low concentration in the House 2 unvented attic**

CAS Number	Volatile Organic Compound (VOC)	H1-T3 ATTIC		H2-T3 ATTIC		Functional Description
		µg/m <sup>3</sup>	ppb	µg/m <sup>3</sup>	ppb	
3033-62-3	Ethanamine, 2,2'-oxybis[N,N-			62.3	9.5	Used in 2-component polyurethane foam.
66-25-1	Hexanal	16.1	3.9	46.6	11.4	Flavor products.
13674-84-5	Tris (1-chloro-2-propyl)phosphate			44.9	3.4	Flame retardant in polyurethane foams.
138-86-3	Limonene (Dipentene; 1-Methyl-4-(1-methylethyl)cyclohexene)	7.9	1.4	37.2	6.7	Used in flavor, fragrance, cosmetics, and cleaning products.
555-10-2	-Phellandrene*	7.4	1.3	34.0	6.1	Phellandrenes are used in fragrances because of their pleasing aromas.
80-56-8	Pinene, (2,6,6-Trimethyl-bicyclo[3.1.1]hept-2-ene)	11.1	2.0	30.0	5.4	Fragrance chemical.
13466-78-9	3-Carene	7.9	1.4	27.3	4.9	Flavor and fragrance products; occurs naturally in turpentine, rosemary, cedar, pine.
127-91-3	Pinene, (6,6-Dimethyl-2-methylene-bicyclo[3.1.1]heptane)	6.1	1.1	22.2	4.0	Fragrance chemical.
124-19-6	Nonyl aldehyde (Nonanal)	6.6	1.1	20.7	3.6	Flavor and fragrance products.
124-13-0	Octanal	4.2	0.8	15.0	2.9	Flavor and fragrance products.
71-41-0	1-Pentanol (N-Pentyl alcohol)	3.2	0.9	14.7	4.1	Food Additive : Functional use(s) - flavor and fragrance agents. Also used in paper products in contact with dry food.
110-62-3	Pentanal	3.7	1.1	12.0	3.4	Flavor, rubber accelerator.
111-71-7	Heptanal (Heptaldehyde)	2.8	0.6	10.9	2.3	Flavor and fragrance products.
111-70-6	1-Heptanol			10.9	2.3	Food Additive : Functional use(s) - flavor and fragrance agents.
140-67-0	Estragole (4-Allylanisole)			8.2	1.4	Flavor and fragrance; distilled from basil.
111-87-5	1-Octanol			7.1	1.3	Food Additive : Functional use(s) - flavor and fragrance agents.
123-35-3	1,6-Octadiene,7-methyl-3-methylene (Myrcene)			6.4	1.1	Fragrance chemical.
99-83-2	-Phellandrene*			6.1	1.1	Phellandrenes are used in fragrances because of their pleasing aromas.
100-52-7	Benzaldehyde	2.1	0.5	5.9	1.4	Almond flavor.
541-02-6	Cyclopentasiloxane, decamethyl	1.7	0.1	5.7	0.4	Cosmetics, personal-care products, manufacture of silicone polymers.
106-42-3	Xylene (para and/or meta)	33.8	7.8			Solvent, paint and varnish thinner.
95-47-6	Xylene, ortho	28.7	6.6			Solvent, paint and varnish thinner.
100-41-4	Benzene, ethyl	6.6	1.5			Used in the production of (polystyrene, and in some paints.
3221-61-2	Octane, 2-methyl	4.3	0.7			Hydrocarbon fuel, solvent.
64-19-7	Acetic acid	2.2	0.9			Vinegar, food additive. Also used industrially in the production of wood glue, synthetic fabrics.
1120-21-4	Undecane	2.1	0.3			Hydrocarbon fuel, solvent.
108-88-3	Toluene (Methylbenzene)	1.9	0.5			Solvent, paint thinner. Also used in adhesives and fuels.

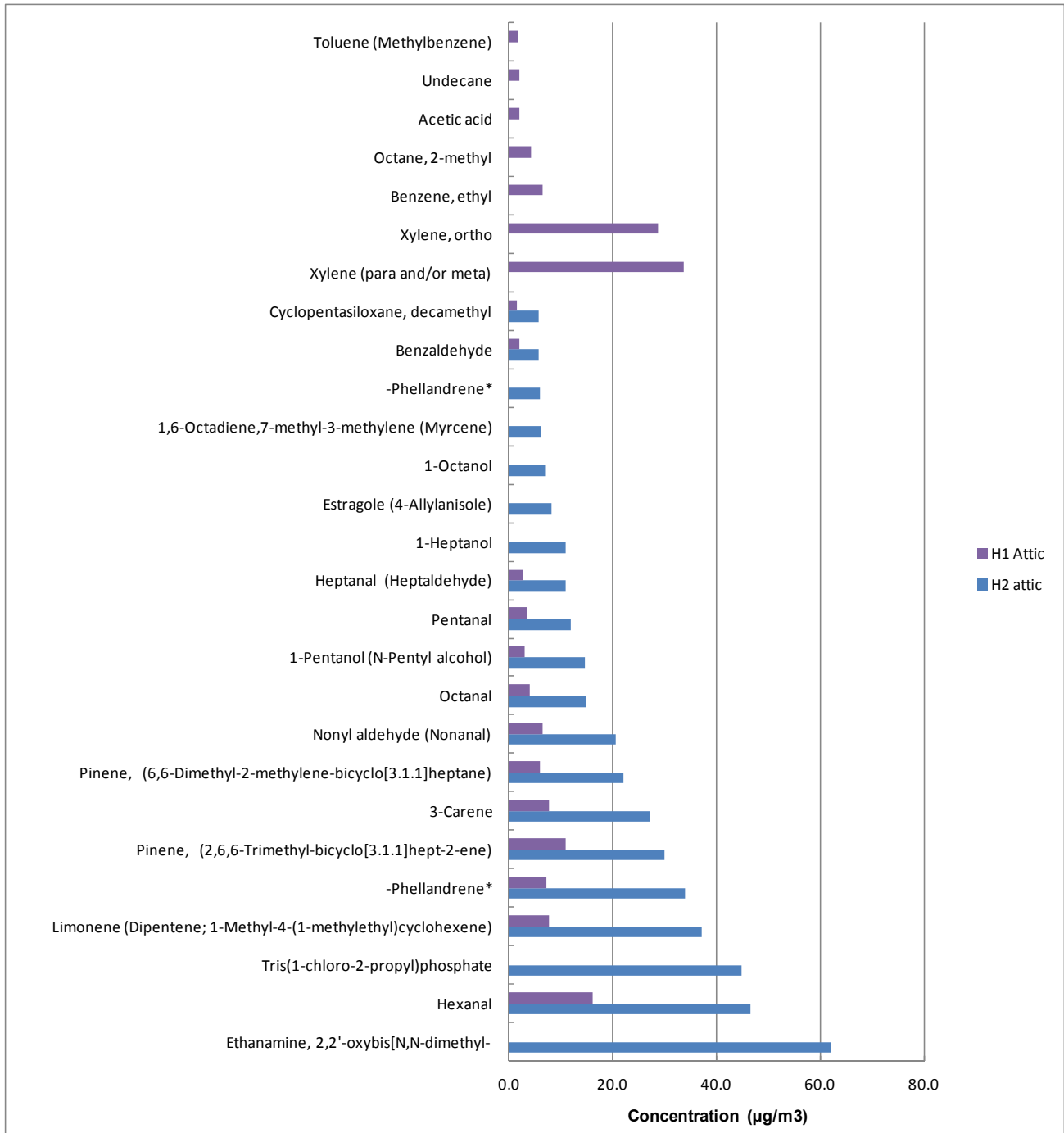

Figure 43. VOCs found in the attics of House 1 and House 2

Table 15. VOCs found in both garages, sorted by highest to lowest in the House 1 garage

CAS Number	Volatile Organic Compound (VOC)	H1-T3 GARAGE		H2-T3 GARAGE	
		µg/m <sup>3</sup>	ppb	µg/m <sup>3</sup>	ppb
138-86-3	Limonene (Dipentene; 1-Methyl-4-(1-methylethyl)cyclohexene)	63.5	11.4	11.6	2.1
66-25-1	Hexanal	21.0	5.1	7.9	1.9
106-42-3	Xylene (para and/or meta)	16.8	3.9		
80-56-8	Pinene, (2,6,6-Trimethyl-bicyclo[3.1.1]hept-2-ene)	16.7	3.0	10.4	1.9
13466-78-9	3-Carene	15.2	2.7	10.5	1.9
555-10-2	-Phellandrene*	13.8	2.5	12.0	2.2
95-47-6	Xylene, ortho	13.6	3.1		
127-91-3	Pinene, (6,6-Dimethyl-2-methylene-bicyclo[3.1.1]heptane)	11.7	2.1	6.8	1.2
124-19-6	Nonyl aldehyde (Nonanal)	9.3	1.6	4.4	0.8
29911-28-2	2-Propanol, 1-(2-butoxy-1-methylethoxy)- (Dipropylene glycol monobutyl ether)	6.0	0.8		
71-41-0	1-Pentanol (N-Pentyl alcohol)	5.5	1.5	2.4	0.7
1120-21-4	Undecane	5.4	0.8		
110-62-3	Pentanal	4.7	1.3	2.2	0.6
124-13-0	Octanal	4.2	0.8	2.3	0.4
112-40-3	Dodecane	3.4	0.5	1.7	0.2
62016-14-2	Octane, 2,5,6-trimethyl*	3.4	0.5		
100-41-4	Benzene, ethyl	3.2	0.7		
140-67-0	Estragole (4-Allylanisole)	3.2	0.5		
111-71-7	Heptanal (Heptaldehyde)	3.1	0.7		
78-93-3	2-Butanone (Methyl ethyl ketone, MEK)	3.0	1.0	1.8	0.6
111-87-5	1-Octanol	3.0	0.6		
110-43-0	2-Heptanone	3.0	0.6		
64-19-7	Acetic acid			6.0	2.4
78-78-4	Butane, 2-methyl (Isopentane)			3.5	1.2
109-66-0	Pentane			3.5	1.2
108-88-3	Toluene (Methylbenzene)			2.6	0.7
108-94-1	Cyclohexanone			2.5	0.6
109-99-9	Furan, tetrahydro (THF)			1.8	0.6
100-52-7	Benzaldehyde			1.6	0.4
586-62-9	Cyclohexene, 1-methyl-4-(1-methylethylidene)*			1.5	0.3
100-42-5	Styrene			1.5	0.2



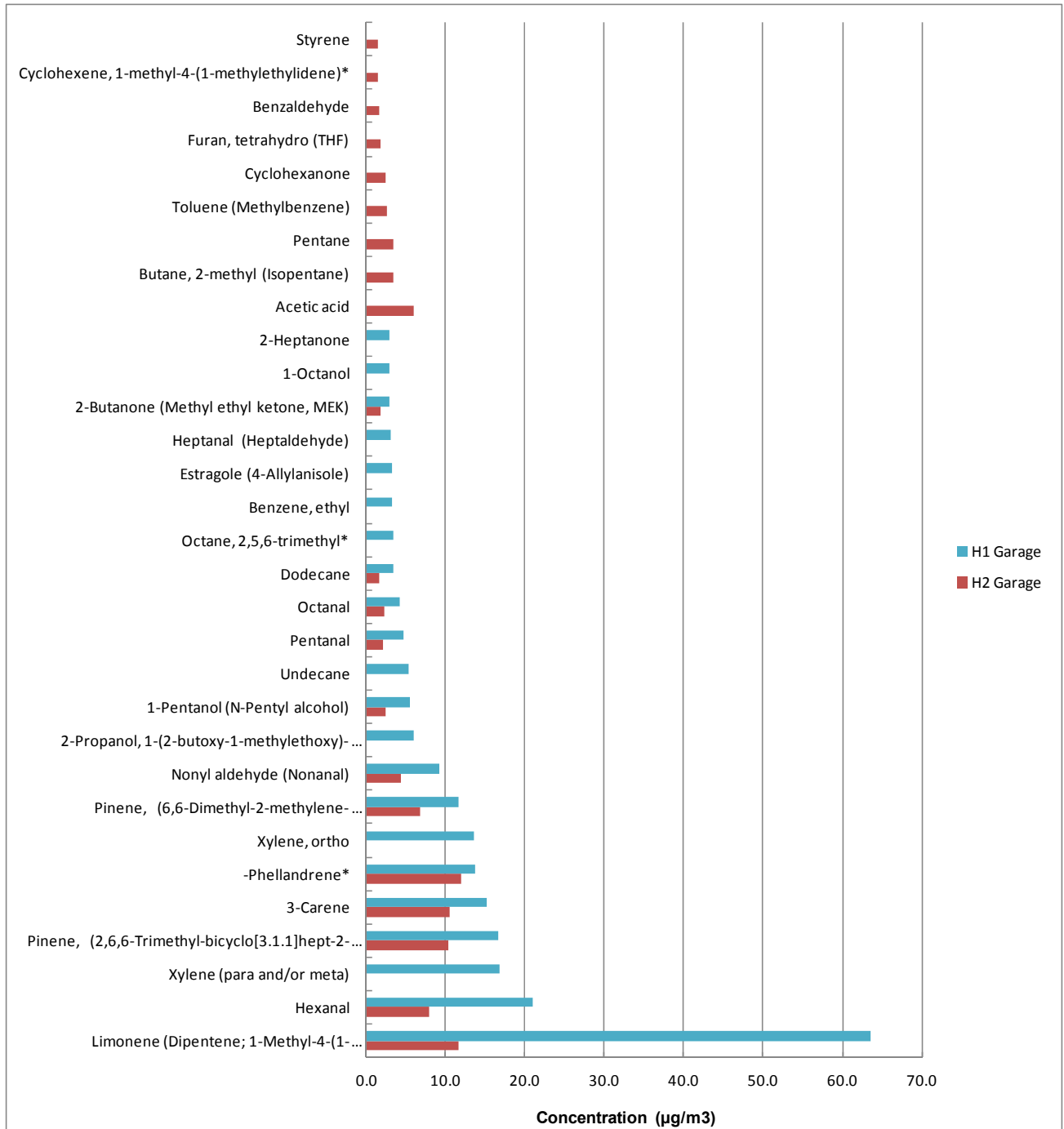

Figure 44. VOCs found in the garages of House 1 and House 2

## 5 Impact for Building America Ventilation Rates

Exhaust ventilation testing showed lower uniformity of outdoor air exchange rate between living space zones, and higher concentrations of particulates, formaldehyde and other Top 20 VOCs than did the supply and balanced ventilation systems. This showed that single-point exhaust ventilation was inferior as a whole-house ventilation strategy. It was inferior because the source of outside air was not direct from outside (much of it came from the attic), the ventilation air was not distributed, and no provision existed for air filtration. Indoor air recirculation by a central air distribution system can help improve the exhaust ventilation system by way of air mixing and filtration. In contrast, the supply and balanced ventilation systems showed that there is a significant benefit to drawing outside air from a known outside location, and filtering and distributing that air.

ASHRAE Standard 62.2 has set a ventilation airflow rate method that does not differentiate between better and worse performing whole-building ventilation systems. The rates set are inferred to be adequate for the worst performing system. System Factors as shown in Table 16 could be applied to allow accounting for ventilation system attributes that improve a system's performance. The System Factors are based on engineering judgment resulting from this study and previous studies (Hendron et al. 2006, 2007; Rudd and Lstiburek 2000, 2001, 2008; Townsend et al. 2009a, 2009b), and extensive work with the ASHRAE Standard 62.2 committee on this subject since 2006. Engineering judgment is valid here since the ASHRAE Standard 62.2 ventilation rates are themselves based only on the engineering judgment and experience of the committee members, not on any health or medical studies. In terms of multi-zone ventilation air change effectiveness, the cited previous research found that fully distributed supply ventilation, operating at half the airflow of single-point exhaust, uniformly ventilated all spaces to a level that equaled or exceeded the ventilation level of the lesser ventilated spaces using the exhaust system. This study added new elements of ventilation effectiveness research, accounting for source of outside air, particle contaminants, and VOC contaminants. These new data give further support for ventilation rate credit for better performing ventilation systems, such as supply and balanced ventilation compared to exhaust, and systems with predictable filtration of outside air and recirculation filtration. The Table 16 System Factors are recommended for consideration in the Building America program to allow credit for better performing ventilation systems. This would yield energy savings and reduced moisture control risk in humid climates, without compromising indoor air quality relative to the worst performing system allowed by ASHRAE Standard 62.2.

**Table 16. Recommended System Factors to reduce ventilation fan airflow rates relative to ASHRAE Standard 62.2-2010 addendum r**

<b>Mechanical Ventilation System Type</b>	<b>With central filtration recirculation*</b>	<b>Without central filtration recirculation</b>
Balanced	0.5	0.7
Unbalanced Supply	0.55	0.75
Unbalanced Exhaust	0.7	1.0

\* Requires minimum whole-house recirculation turnover of 0.7 ach with minimum MPR 700 or MERV 9 filter. Minimum whole-house recirculation turnover defined as: (AHU cfm)(minimum runtime min/h) / (conditioned floor area\*8 ft).

The numerical basis for the System Factors shown in Table 16 is given in Table 17. The values shown in Table 17 are percentage reductions, based on engineering judgment from this and previous studies, for each system improvement that exists for a given ventilation system based on the four System Factor Categories of Balance, Distribution, OA Source, and Recirculation Filtration. Balance is where the mechanical ventilation system supplies to the house substantially the same amount of air that it exhausts from the house. That generally increases total air exchange somewhat since, with balanced ventilation, mechanical ventilation mostly sums with natural infiltration. Distribution is where direct outside air is supplied to at least all of the bedrooms, where occupants typically spend the most continuous time. OA Source is where outside air comes directly from a known fresh air source, not drawn through potentially contaminated building enclosure elements or adjacent spaces such as garages, attics, and crawlspaces. Recirculation Filtration is where a mechanical system, such as a central heating and cooling system, recirculates a minimum of 70% of the house air volume each hour through an air filter with minimum MPR 700 or MERV 9. The Recirculation Filtration category is given the highest weight in light of recent determinations that particulate contamination presents by far (10 times more than the next closest risk) the greatest risk to human health in residential indoor environments (Logue 2011). Referring again to Table 17, as an example, a Balanced-type ventilation system with whole-building recirculation filtration earns ventilation airflow reduction credit in all four system factor categories. An Unbalanced Exhaust-type ventilation system without whole-building recirculation filtration earns no ventilation airflow reduction credits.

**Table 17. Numerical basis for the System Factors shown in Table 16, given as percent airflow rate reduction for each System Factor Category**

	<b>Percent Reduction from the 62.2-2010 addendum r Ventilation Rates due to listed System Factor Categories</b>									
	<b>With Whole-Building Recirculation Filtration</b>					<b>Without Whole-Building Recirculation Filtration</b>				
	System Factor Categories					System Factor Categories				
<b>Whole-Building Mechanical Ventilation System Type</b>	Balance	Distribution	OA Source	Recirculation Filtration	Total	Balance	Distribution	OA Source	Recirculation Filtration	Total
Balanced	5	10	15	20	50	5	10	15		30
Unbalanced Supply		10	15	20	45		10	15		25
Unbalanced Exhaust		10		20	30					0

## 6 Conclusions and Recommendations

The research presented here was intended to develop a better understanding of whole-building ventilation system effectiveness and distribution in low energy homes which is critical to promoting the best low-energy and high-value ventilation solutions. Through this research project BSC sought to address the following research questions. The answers to those questions are provided below in the form of conclusions and recommendations:

1. *Do different whole-building ventilation systems perform significantly differently in terms of their ability to deliver uncontaminated ventilation air to the occupants?*

The testing showed that single-point exhaust ventilation was inferior as a whole-house ventilation strategy. It was inferior because the source of outside air was not direct from outside (much of it came from the attic), the ventilation air was not distributed, and no provision existed for air filtration. Indoor air recirculation by a central air distribution system can help improve the exhaust ventilation system by way of air mixing and filtration. In contrast, the supply and balanced ventilation systems showed that there is a significant benefit to drawing outside air from a known outside location, and filtering and distributing that air.

In terms of internal air distribution, the Baseline system showed little interzonal airflow in all cases. All systems showed little interzonal airflow between bedrooms. The most interzonal airflow was between the Main zone and bedroom zones for the CFIS and Exhaust with mixing cases. The Exhaust cases showed significant airflow from Main to Master and no airflow in the reverse direction, as expected with the exhaust fan located in the Master zone. Otherwise, the Exhaust systems showed little interzonal airflow and distribution of ventilation air. The ERV system showed little airflow from Main to bedrooms and between bedrooms, but relatively high airflow from bedrooms to the Main zone, as expected since the ERV system supplied fresh air to the bedrooms and exhausted stale air from the Main zone.

2. *What measurements and testing protocols are needed to appropriately account for the source of outside air relevant to occupant exposure to chemical and particulate contaminants in residential environments?*

The full test battery applied in this research project was utilized to answer the research questions posed. No planned measurement was found to be unneeded. The PFT testing and analysis was required to identify and compare zone air change rates and inter-zonal airflow which bore on the ventilation air distribution question. The interzonal airflow results also informed the finding of high particle counts using exhaust ventilation where a substantial amount of the ventilation air came from the attic environment. The particulate, formaldehyde, and other VOC measurements taken in more than one zone supported the consistency and reliability of the measurement and analysis methods, and showed clear differences in the resulting indoor air quality between ventilation systems. Indoor and outdoor temperature and relative humidity temperature, and wind speed measurements provided assurance that significant differences would not be related to those factors. The extensive building characterization measurements made sure that there were not large anomalies in building enclosure air leakage, or mechanical system operation and allowed for future modeling to expand the findings beyond the measured test results.

3. *What is the overall indoor air quality impact of operating an exhaust whole-building ventilation system versus supply and balanced ventilation?*

Exhaust ventilation testing showed lower uniformity of outdoor air exchange rate between living space zones, and higher concentrations of particulates, formaldehyde and other Top 20 VOCs than did the supply and balanced ventilation systems.

4. *For whole-building ventilation systems that do not draw outside air directly from a known fresh air source, how much of the ventilation air is drawn through potentially contaminated adjacent spaces such as garages and vented attics?*

For the two houses studied, exhaust ventilation testing showed that only a small amount of air was drawn from the garage while a considerable amount was drawn from the attics, more so from the vented attic. The Exhaust ventilation system in House 1 was moving 20% of its air ventilation air from the vented attic to the Main zone. Another 14% of the Exhaust ventilation air in House 1, was moving from the Attic to the bedroom zones. A total of 34% of the ventilation air for the Exhaust system in House 1 was coming from the vented attic. In comparison, for the unvented attic of House 2, the Exhaust system moved only 2% of its ventilation air from the Attic to the Main zone. This indicates that the exhaust makeup air resistance path to outside was greater through the unvented attic than through the vented attic and an Exhaust ventilation system may perform better in an unvented attic house.

5. *What is the impact of drawing outdoor air through the building enclosure and adjacent unoccupied spaces on the level of particulate contaminants within the conditioned space?*

Drawing air through the building enclosure and adjacent spaces via exhaust ventilation showed higher concentrations of particulates relative to ventilation systems that had direct outside air intake and filtered that air. The highest particulate levels were found for the Exhaust system, followed by the Baseline or ERV, followed by the Exhaust with mixing and CFIS. CFIS always showed the lowest particle counts regardless of particle size. This indicated, as expected, that the filters in the central air distribution system were removing a significant amount of particle contaminant 0.3 micron and larger. The CFIS ventilation system showed an 85% and 73% reduction in 0.3-2.0 micron particles for House 1 and House 2, respectively, attributable to recirculation air filtration by operation of the central air distribution system.

6. *What is the impact of drawing outdoor air through the building enclosure and adjacent unoccupied spaces on the level of chemical contaminants within the conditioned space?*

Drawing air through the building enclosure and adjacent spaces via exhaust ventilation showed higher concentrations of formaldehyde and other Top 20 VOCs.

In House 1, all ventilation systems reduced the formaldehyde concentration over the Baseline concentration which was roughly 15 to 20 times higher than what would be expected outdoors. Exhaust-only ventilation reduced the indoor formaldehyde concentration the least, followed by Exhaust with mixing, CFIS, and ERV. In House 2, the Exhaust systems either increased or did not appreciably change the formaldehyde concentration in the Main and Master zones. The CFIS and ERV systems showed a significant reduction in formaldehyde concentration over the

Baseline, and Exhaust tests. In general for both houses, the CFIS and ERV systems showed a 60% to 70% reduction in formaldehyde concentration over Exhaust.

Formaldehyde concentration was also measured in the attics and garages of both houses during the Exhaust with mixing test. The vented attic concentration was about 3 times higher than what would be expected for outdoors, while the unvented attic and the garages were about 8 to 10 times higher.

Concentrations of the Top 20 Volatile Organic Compounds (VOCs) were reported by the lab analysis. The trend found in the Main and Master zones was that the Baseline test tended to show the highest VOC concentrations, followed by the Exhaust and Exhaust with mixing ventilation systems, then the CFIS and ERV ventilation systems. In a few cases the order was different, and in some cases the results for all systems were relatively close to each other.

The highest VOC concentrations found in House 1 were for Xylene and Benzene, solvents used in sealing the decoratively stained concrete floors throughout both houses. In House 2, a floor sealer was used that was designed to be lower-emitting than the sealer used in House 1, and it apparently worked as advertised. House 2 also used a special gypsum board reported to absorb VOCs. Besides the Xylene, Benzene, and Toluene solvents used in finishing the stained concrete floors in House 1, the seemingly harmless balance of predominant compounds found in both houses were:

- Pinene - used as a fragrance chemical

- Limonene - used in flavor, fragrance, cosmetics, and cleaning products

- Hexanal - used in flavor products

- Carene - used in flavor and fragrance products; occurs naturally in turpentine, rosemary, cedar, pine

- Phellandrene - used in fragrances.

Total Volatile Compound (TVOC) data showed that, compared to the Exhaust system, the CFIS and ERV ventilation systems reduced TVOC by 47% and 57%, respectively, averaged between the two houses. Compared to the Baseline tests, the Exhaust system increased TVOC by 37% in the House 1 Main zone, and increased TVOC by 18% in the House 2 Master zone. This highlights that the unknown air path, or source of outside air, for the Exhaust ventilation system can cause indoor air to be more contaminated depending on what contaminants are picked up on the way in.

7. *Does the testing and modeling conducted provide justification for lower ventilation rates for fully-distributed whole-building ventilation systems drawing outside air from a known fresh air location compared to lower performing systems?*

Yes, qualitatively and quantitatively to different extents within the scope and budget of this research project. The measurements are not without uncertainty, however, compensating logical support is found considering the fact that the same trends were found in two side-by-side houses, and that the trends agree with expected physical phenomena. For the two distributed whole-building ventilation systems (CFIS and ERV) drawing outside air directly from a known fresh air location, uniformity of outdoor air exchange rate was better, and the concentrations of particulates, formaldehyde and other Top 20 VOCs were lower compared to the exhaust system.

While analysis did not quantify the collective effect of reduced contaminant exposure to occupants, engineering judgment can be applied based on the quantitative testing results of the individual factors. Engineering judgment is valid here since the ASHRAE Standard 62.2 ventilation rates are themselves based only on the engineering judgment and experience of the committee members, not on any health or medical studies. Values for percent reductions in ventilation airflow were assigned for each system improvement that exists for a given ventilation system. These values were then summed to give a total percent reduction. The individual system improvements were based on four System Factor Categories: Balance, Distribution, OA Source, and Recirculation Filtration, The resulting System Factors could be applied to reduce ventilation fan airflow rates relative to ASHRAE Standard 62.2-2010 addendum r. This is recommended for consideration in the DOE Building America and Challenge Home programs to save energy and reduce moisture control risk in humid climates.

## Acknowledgements

The authors are grateful to Roy Crawford, Ph.D. and John Vasselli of the Texas Allergy, Indoor Environment, & Energy Institute (TxAIRE) at The University of Texas at Tyler for offering the unique opportunity to use the two TxAIRE lab houses for this research. In addition, the real-world experience and help offered by Dr. Crawford greatly facilitated our efforts.

Sincere appreciation is also extended to Fluke Corporation and UL Air Quality Sciences, Inc. for assisting financially with the airborne particle counting and VOC/formaldehyde phases of the project. Thanks to Terry Sullivan at Brookhaven National Laboratory for his technical guidance with the PFT testing, and to Colin Olson of the Energy Conservatory for his consultations concerning the multi-zone fan pressurization testing.

## References

- ASHRAE. Handbook of Fundamentals (2009) American Society of Heating, Refrigerating and Air-Conditioning Engineers, Inc.
- Carl-Gustaf Bornehag, Jan Sundell, Charles J. Weschler, Torben Sigsgaard, Björn Lundgren, Mikael Hasselgren, and Linda Hägerhed-Engman. 2004. "The Association between Asthma and Allergic Symptoms in Children and Phthalates in House Dust: A Nested Case-Control Study" *Environ Health Perspect.* 2004 October; 112(14): 1393–1397.
- Christensen, Craig, Ren Anderson, Scott Horowitz, Adam Courtney, and Justin Spencer. 2006. "BEopt™ Software for Building Energy Optimization: Features and Capabilities." National Renewable Energy Laboratory, August 2006 • NREL/TP-550-39929.
- Dietz, Russell N. 2006. "Instructions: Brookhaven Air Infiltration Measurement System." Brookhaven National Laboratory, Upton, NY. Revised: February 2006.
- Dodson, Robin E., Jonathan I. Levy, James P. Shine, John D. Spengler, Deborah H. Bennett. 2007. "Multi-zonal air flow rates in residences in Boston, Massachusetts." *Atmospheric Environment* 41 (2007) 3722–3727.
- EPA 1991. EPA Aerometric Information Retrieval System (AIRS).

Hendron, B., R. Anderson, D. Barley, E. Hancock 2006. Building America Field Test and Analysis Report. Draft NREL report.

Hendron, R., A. Rudd, R. Anderson, D. Barley, A. Townsend 2007. Field Test of Room-to-Room Distribution of Outside Air with Two Residential Ventilation Systems. IAQ 2007: Healthy & Sustainable Buildings Conference Proceedings. American Society of Heating, Refrigerating and Air-Conditioning Engineers, Inc.

Hodgson, A.T., A. Rudd, D. Beal and S. Chandra, 2000. Volatile Organic Compound Concentrations and Emission Rates in New Manufactured and Site-Built Houses. *Indoor Air* 10: 178-192.

IAQ Source 2013. <http://www.iaqsource.com/article.php/comparing-3m-filtrete-filters/?id=19>

Leadererr, Brian P., Luc Schaap, Russell N. Dietz. 1995. "Evaluation of the Perfluorocarbon Tracer Technique for Determining Infiltration Rates in Residences." *Environ. Sci. Technol.*, Vol. 19, No. 12, 1225-1232.

Logue, J.M., P.N. Price, M. H. Sherman, B.C. Singer 2001. "A Method to Estimate the Chronic Health Impact of Air Pollutants in U.S. Residences." Lawrence Berkeley National Laboratory, Environmental Energy Technologies Division, LBNL Report Number 5267E, November.

Offermann, F. J. 2009. "Ventilation and Indoor Air Quality in New Homes." California Air Resources Board and California Energy Commission, PIER Energy-Related Environmental Research Program. Collaborative Report. CEC-500-2009-085, November.

Rudd, Armin, and Joseph Lstiburek 2008. "Systems Research on Residential Ventilation." Proceedings of the 2008 ACEEE Summer Study on Energy Efficiency in Buildings, Pacific Grove, California, August. American Council for an Energy Efficient Economy, Washington, D.C.

Rudd, Armin, Hugh Henderson, Jr., 2007. "Monitored Indoor Moisture and Temperature Conditions in Humid Climate U.S. Residences." ASHRAE Transactions (17, Dallas 2007). American Society of Heating Refrigeration and Air-Conditioning Engineers, Atlanta, GA.

Rudd, Armin, Joseph Lstiburek 2001. "Clean Breathing in Production Homes." *Home Energy Magazine*, May/June, Energy Auditor & Retrofiter, Inc., Berkeley, CA.

Rudd, Armin, Joseph Lstiburek 2000. "Measurement of Ventilation and Interzonal Distribution in Single-Family Homes." ASHRAE Transactions 106(2):709–18, MN-00-10-3, V.106, Pt.2., American Society of Heating Refrigeration and Air-Conditioning Engineers, Atlanta, GA.

Rudd, Armin, and Joseph Lstiburek 1999. Design methodology and economic evaluation of central-fan-integrated supply ventilation systems. *Indoor Air* 5:25-30. Air Infiltration and Ventilation Center, Coventry, United Kingdom.

Townsend, A., A. Rudd, and J. Lstiburek 2009a. Extension of Ventilation System Tracer Gas Testing Using a Calibrated Multi-Zone Airflow Model. ASHRAE Transactions 115(2).



Townsend, A., A. Rudd, and J. Lstiburek 2009b. A Method for Modifying Ventilation Airflow Rates to Achieve Equivalent Occupant Exposure. ASHRAE Transactions 115(2).

Walton, G. and W.S. Dols 2010. "CONTAM User Guide and Program Documentation." NISTIR 7251, <http://www.bfrl.nist.gov/IAQanalysis/CONTAM/userguide.htm>, December.

Weisel CP, Zhang J, Turpin BJ, Morandi MT, Colome S, Stock TH, Spektor DM, Korn L, Winer A, Alimokhtari S, Kwon J, Mohan K, Harrington R, Giovanetti R, Cui W, Afshar M, Maberti S, Shendell D. 2005. "Relationship of Indoor, Outdoor and Personal Air (RIOPA) study." Journal of Exposure Analysis and Environmental Epidemiology, Mar;15(2):123-37. Environmental and Occupational Health Sciences Institute, Piscataway, NJ USA.

## **Appendix A. Listing of all Top 20 Volatile Organic Compounds Found, and their Functional Descriptions**

CAS Number	Volatile Organic Compound (VOC)	Functional Descriptions	Source
99-83-2	-Phellandrene*	Phellandrenes are used in fragrances because of their pleasing aromas.	Wikipedia
555-10-2	-Phellandrene*		
5794-03-6	(+)-Camphene	Fragrance chemical.	
107-21-1	1,2-Ethandiol (Ethylene glycol)	Ethylene glycol is an organic compound widely used as an automotive antifreeze and a precursor to polymers. In its pure form, it is an odorless, colorless, syrupy, sweet-tasting liquid. Ethylene glycol is toxic, and ingestion can result in death.	
123-35-3	1,6-Octadiene,7-methyl-3-methylene (Myrcene)	Fragrance chemical.	
71-36-3	1-Butanol (N-Butyl alcohol)	Present in many foods and beverages. It is also a permitted artificial flavorant in the United States, used in butter, cream, fruit, rum, whiskey, ice cream and ices, candy, baked goods and cordials. It is also used in a wide range of consumer products.	Wikipedia
111-70-6	1-Heptanol	Food Additive : Functional use(s) - flavor and fragrance agents.	
111-87-5	1-Octanol	Food Additive : Functional use(s) - flavor and fragrance agents.	
71-41-0	1-Pentanol (N-Pentyl alcohol)	Food Additive : Functional use(s) - flavor and fragrance agents. Also used in paper products in contact with dry food.	
78-93-3	2-Butanone (Methyl ethyl ketone, MEK)	Used in products such as lacquer, varnishes, paint remover, a denaturing agent for denatured alcohol, glues, and as a cleaning agent.	wikipedia
110-43-0	2-Heptanone	Listed by the FDA as a "food additive permitted for direct addition to food for human consumption." It occurs naturally in certain foods such as beer, white bread, butter, various cheeses and potato chips.	wikipedia
2548-87-0	2-Octenal, (E)*	Food and perfume additive; can also result from oxidation of cooked food.	<a href="http://en.wikipedia.org/wiki/Warmed-over_flavor">http://en.wikipedia.org/wiki/Warmed-over_flavor</a> <a href="http://www.flavornet.org/info/2548-87-0.html">http://www.flavornet.org/info/2548-87-0.html</a>
29911-28-2	2-Propanol, 1-(2-butoxy-1-methylethoxy)- (Dipropylene glycol monobutyl ether)	Uses include: 1) coupling agent used as a blending facilitator for cleaners such as degreasers, paint removers, metal cleaners and hard surface cleaners; 2) coalescent for lowering the minimal film forming temperature in latex coatings; 3) solvent for water-reducible coatings; 4) chemical intermediate for production of epoxides, acid ester derivatives, solvents, and plasticizers.	<a href="http://www.arb.ca.gov/consprod/regact/2010ra/dpnb29911282.pdf">www.arb.ca.gov/consprod/regact/2010ra/dpnb29911282.pdf</a>
20324-32-7	2-Propanol, 1-(2-methoxy-1-methylethoxy)*	Used in the manufacture of a wide variety of industrial and commercial products, including paints, varnishes, inks, and cleaners.	OECD SIDS DIPROPYLENE GLYCOL METHYL ETHER
5131-66-8	2-Propanol, 1-butoxy	A colorless combustible liquid with an ether-like odor. It has low water solubility and good coupling and demonstrates good solvency for coating resins. Used in agricultural, coating, cleaning, ink, textile and adhesive products, and as substitute for ethylene glycol ethers.	<a href="http://www.lyondellbasell.com/techlit/techlit/2395.pdf">www.lyondellbasell.com/techlit/techlit/2395.pdf</a>
13466-78-9	3-Carene	Flavor and fragrance products; occurs naturally in turpentine, rosemary, cedar, pine.	Wikipedia
123-86-4	Acetate, butyl	Found in many types of fruit, where along with other chemicals it imparts characteristic flavors and has a sweet smell of banana or apple. It is used as a synthetic fruit flavoring in foods such as candy, ice cream, cheeses, and baked goods. Also used in the production of lacquers.	wikipedia
64-19-7	Acetic acid	Vinegar, food additive. Also used industrially in the production of wood glue, synthetic fabrics.	wikipedia
100-52-7	Benzaldehyde	Benzaldehyde occurs in almonds, apricots, apples, and cherry kernels. It is an almond flavorant, and is also used as bee repellent.	wikipedia
98-82-8	Benzene, 1-methylethyl (Cumene)	Used as a thinner for paints, lacquers, and enamels and as a component of high octane fuels. The most probable route of human exposure is by the inhalation of contaminated air from the evaporation of petroleum products.	<a href="http://www.epa.gov/tthatw01/hlthef/cumene.html">http://www.epa.gov/tthatw01/hlthef/cumene.html</a>
100-41-4	Benzene, ethyl	Used in the production of (polystyrene, and in some paints.	wikipedia
78-78-4	Butane, 2-methyl (Isopentane)	Used in toothpaste, cosmetics, body washes.	<a href="http://www.wisegeek.com/what-is-isopentane.htm">http://www.wisegeek.com/what-is-isopentane.htm</a> , wikipedia
108-94-1	Cyclohexanone	Feedstock for production of nylon.	
540-97-6	Cyclohexasiloxane, dodecamethyl	Feedstock for silicone plastics. Silicone plastics have many applications; cosmetics and toiletries probably dominate human exposure.	<a href="http://oehha.ca.gov/multimedia/biomon/pdf/1208cyclosiloxanes.pdf">oehha.ca.gov/multimedia/biomon/pdf/1208cyclosiloxanes.pdf</a>
586-62-9	Cyclohexene, 1-methyl-4-(1-methylethylidene)*	Flavor and fragrance; scent of pine.	<a href="http://www.flavornet.org/info/586-62-9.html">http://www.flavornet.org/info/586-62-9.html</a>

CAS Number	Volatile Organic Compound (VOC)	Functional Descriptions	Source
541-02-6	Cyclopentasiloxane, decamethyl	Cosmetics, toiletries, dry-cleaning.	oehha.ca.gov/multimedia/biomon/pdf/1208cyclosiloxanes.pdf
556-67-2	Cyclotetrasiloxane, octamethyl	Cosmetics, personal-care products, manufacture of silicone polymers.	oehha.ca.gov/multimedia/biomon/pdf/1208cyclosiloxanes.pdf
112-40-3	Dodecane	Hydrocarbon fuel, solvent.	wikipedia
109-99-9	Furan, tetrahydro (THF)	Solvent for PVC; used in varnishes; feedstock for spandex and similar materials.	wikipedia
140-67-0	Estragole (4-Allylanisole)	Flavor and fragrance; distilled from basil.	wikipedia
3033-62-3	Ethanamine, 2,2'-oxybis[N,N-dimethyl-	Used in 2-component polyurethane foam.	
111-90-0	Ethanol, 2-(2-ethoxyethoxy) (Diethylene glycol monoethyl ether)	Solvent in paint and wood finishes. It is included in wood stains, stamping inks, leather dyes, printing inks and pastes.	german wikipedia, google translate
111-76-2	Ethanol, 2-butoxy	A solvent in paints and surface coatings, as well as cleaning products and inks. Used in acrylic resin formulations, asphalt release agents, firefighting foam, leather protectors, oil spill dispersants, degreaser applications, and photographic strip solutions. Used as a primary ingredient include some whiteboard cleaners, liquid soaps, cosmetics, dry cleaning solutions, lacquers, varnishes, herbicides, and latex paints. Frequently found in popular cleaning products. It is the main ingredient of many home, commercial and industrial cleaning solutions	wikipedia
111-71-7	Heptanal (Heptaldehyde)	Flavor and fragrance products.	wikipedia
142-82-5	Heptane	Used in paints and coatings, used as the rubber cement solvent "Bestine", used as the outdoor stove fuel "Powerfuel" by Primus, used as pure n-Heptane for research and development and pharmaceutical manufacturing and as a minor component of gasoline.	wikipedia
66-25-1	Hexanal	Flavor products.	wikipedia
589-34-4	Hexane, 3-methyl	Hydrocarbon fuel, solvent.	wikipedia
138-86-3	Limonene (Dipentene; 1-Methyl-4-(1-methylethyl)cyclohexene)	Used in flavor, fragrance, cosmetics, and cleaning products.	wikipedia
111-84-2	Nonane	Hydrocarbon fuel, solvent.	wikipedia
124-19-6	Nonyl aldehyde (Nonanal)	Flavor and fragrance products.	wikipedia
124-13-0	Octanal	Flavor and fragrance products.	wikipedia
62016-14-2	Octane, 2,5,6-trimethyl*	Hydrocarbon fuel, solvent.	wikipedia
3221-61-2	Octane, 2-methyl	Hydrocarbon fuel, solvent.	wikipedia
110-62-3	Pentanal	Flavor, rubber accelerator.	wikipedia
109-66-0	Pentane	Hydrocarbon fuel, solvent. Blowing agent for polystyrene foams.	wikipedia
80-56-8	Pinene, (2,6,6-Trimethyl-bicyclo[3.1.1]hept-2-ene)	Fragrance chemical.	wikipedia
127-91-3	Pinene, (6,6-Dimethyl-2-methylene-bicyclo[3.1.1]heptane)	Fragrance chemical.	wikipedia
629-59-4	Tetradecane	Hydrocarbon fuel, solvent.	wikipedia
100-42-5	Styrene	Plastic monomer.	wikipedia
108-88-3	Toluene (Methylbenzene)	Solvent, paint thinner. Also used in adhesives and fuels.	wikipedia
13674-84-5	Tris(1-chloro-2-propyl)phosphate	Flame retardant in polyurethane foams.	www.inchem.org/documents/sids/sids/13674845.pdf
1120-21-4	Undecane	Hydrocarbon fuel, solvent.	wikipedia
106-42-3	Xylene (para and/or meta)	Solvent, paint and varnish thinner.	wikipedia
95-47-6	Xylene, ortho	Solvent, paint and varnish thinner.	wikipedia

## Appendix B. Preliminary CONTAM Model

CONTAM (Walton 2010) is a multizone indoor air quality and ventilation analysis computer program designed help determine: (a) airflows in building systems driven by mechanical and natural means; (b) contaminant concentrations transported by these airflows; and (c) personal exposure of occupants to airborne contaminants. In future work, further analysis using the CONTAM model started in this project would allow expansion of this work for evaluating ventilation system impacts over a year-long period, and for different climates. A fully developed model could be calibrated using the tracer gas airflow results, then used to expand the capability to further explore the source of outside air and ventilation air distribution effects over a broader range of conditions, such as: different seasons, climates, enclosure leakage rates, ventilation systems, ventilation control strategies, and air filtration/air cleaning strategies.

### B.1 Building and Zonal Leakage Characterization by Fan Pressurization Testing

**Detailed whole-building and zonal leakage fan pressurization test results, including those from numerous guarded tests are given in**

Table B- 1 for House 1 and Table B- 2 for House 2. Leakage to outside was measured by means of a guarded test on each room/zone. Guarding the test zone was accomplished by using one or two more calibrated fans, and combinations of door opening, to take the pressure of the adjacent zones to the same pressure with respect to outside as the test zone. Total leakage of each zone was measured by exposing all bordering spaces to outdoors. Leakage to inside was calculated as the difference between total leakage and leakage to outside for each zone. The multi-point tests were conducted at pressures between -15 and -50 Pa with respect to outside, enabling determination of a flow exponent and constant from a power-law curve fit to predict flows at different pressures and for modeling.

Table B- 1. House 1 Guarded and Unguarded Fan Pressurization Test Results

	Power Law Fit Coefficients		Airflow (CFM) at Listed Test Pressure Differential				
	C	n	15	25	30	40	50
<b>Total Leakage</b>							
House	66.2	0.706	448	642	731	895	1048
House + Garage	110.0	0.625	598	822	922	1103	1268
Garage	31.7	0.661	190	266	300	363	421
Master	27.8	0.622	150	206	231	276	317
Middle	8.2	0.639	46	64	72	87	100
Bath 2	4.7	0.612	25	34	38	45	52
Front	10.4	0.615	55	75	84	101	115
<b>Leakage to Outside</b>	<b>C</b>	<b>n</b>	<b>15</b>	<b>25</b>	<b>30</b>	<b>40</b>	<b>50</b>
Master	13.3	0.693	87	124	140	171	200
Middle	2.5	0.824	23	36	41	52	63
Bath 2	Below Measurable Limit						
Front	6.6	0.677	42	59	66	81	94
House to Out	56.9	0.727	407	590	674	830	977
Main to Out	34.8	0.737	255	372	426	526	620
Garage to Out	25.0	0.686	160	227	258	314	366
<b>Leakage to Inside</b>	<b>C</b>	<b>n</b>	<b>15</b>	<b>25</b>	<b>30</b>	<b>40</b>	<b>50</b>
Master	15.7	0.514	63	82	90	105	117
Middle	7.9	0.397	23	28	30	34	37
Bath 2	4.7	0.612	25	34	38	45	52
Front	4.7	0.390	14	17	18	20	22
<b>Interzonal Leakage</b>	<b>C</b>	<b>n</b>	<b>15</b>	<b>25</b>	<b>30</b>	<b>40</b>	<b>50</b>
Garage to Main	7.4	0.511	30	39	42	49	55

**Table B- 2 House 2 (unvented attic) Guarded and Unguarded Fan Pressurization Test Results**

	Power Law Fit Coefficients		Airflow (CFM) at Listed Test Pressure Differential				
	C	n	15	25	30	40	50
<b>Total Leakage</b>							
House + Attic	67.1	0.630	370	510	572	686	789
House + Attic + Garage	83.0	0.667	505	710	802	972	1128
House	136.8	0.613	719	984	1100	1313	1505
Attic	164.5	0.550	729	966	1068	1251	1414
Garage	62.2	0.639	351	486	547	657	758
Master	33.3	0.598	168	228	255	302	345
Middle	38.2	0.560	174	232	257	301	342
Bath 2	4.8	0.610	25	34	38	46	52
Front	13.8	0.590	68	92	103	122	139
<b>Leak to Outside</b>	<b>C</b>	<b>n</b>	<b>15</b>	<b>25</b>	<b>30</b>	<b>40</b>	<b>50</b>
Master	4.5	0.540	19	25	28	33	37
Middle	0.2	1.000	3	6	7	9	11
Bath 2	Below Measurable Limit						
Front	0.3	0.976	4	6	8	10	13
Attic to Out	105.6	0.558	479	636	705	827	937
Garage to Out	50.7	0.671	312	440	497	603	700
House to Out	68.8	0.677	430	608	688	836	972
Main to Out	64.7	0.676	404	570	645	783	911
<b>Leakage to Inside</b>	<b>C</b>	<b>n</b>	<b>15</b>	<b>25</b>	<b>30</b>	<b>40</b>	<b>50</b>
Master	28.9	0.605	149	203	226	269	308
Middle	38.7	0.549	171	227	250	293	331
Bath 2	4.8	0.610	25	34	38	46	52
Front	14.1	0.560	64	86	95	111	126
<b>Interzonal Leakage</b>	<b>C</b>	<b>n</b>	<b>15</b>	<b>25</b>	<b>30</b>	<b>40</b>	<b>50</b>
Attic to House	59.0	0.534	251	329	363	423	477
Garage to Main	16.2	0.327	39	46	49	54	58

The guarded tests on House 2 were particularly challenging because of the strong interzonal airflow between the house and the unvented attic. Small differences in pressure between the house and attic corresponded to large airflows between the two spaces. The solution was to use more automation in the testing via the cruise control built into some digital manometers and computer software for blower door testing. The guarded testing in House 2 required three fans--- one for the room under test, one for the house front door, and one for the unvented attic. One is manually driven to the chosen pressure relative to outside, while the other two zones are matched

to that pressure under computer control. A further challenge came from the very low leakage to outside in the secondary bedrooms and hall bathroom, once the attic leakage was eliminated by guarding. At the standard test pressures of 15 to 50 Pa, the leakage was below measurable limits. Test results were recorded at flows between 20 and 50 CFM, with pressures as high as 150 Pa. The power law flow coefficients were fit from the measured data.

### B.2 Leakage Inputs for CONTAM Modeling

A preliminary CONTAM model was constructed for each of the houses using the physical characteristics, and the measured air leakage and mechanical airflow characteristics. The CONTAM model of the house includes leaks only between physically adjacent zones. For the 6 zones in House 1 (where the attic is taken to be outside), this reduces the total number of modeled leaks from 21 to 11. However, with each room being adjacent to two or more others, the guarded tests of total leakage to inside do not uniquely determine the path of measured leakage area to inside. We initially planned that the leakage to inside for each subject room could be distributed proportionally relative to interior wall area, but analysis of the measurements showed that a second weighting may be needed to account for the fact that adjacent rooms can have very different total leakage to inside, biasing the direction of airflow from the subject room. Therefore, initial leakage areas were chosen to limit leakage to be consistent with all the airflow measurements (i.e. more air could not flow in than could flow out). These are estimates, to be refined when the CONTAM model can be fit to the tracer gas measurements. Table B- 3 and Table B- 4 show the initial leakage flow coefficients for the CONTAM model. Doors are entered separately, according to their known area.

**Table B- 3. House 1 CONTAM Model Inputs**

Leakage Path		Power Law Coefficients	
From	To	C	n
Main	Out	34.8	0.737
Main	Master	14.8	0.514
Main	Middle	0.1	0.500
Main	Garage	7.4	0.511
Master	Out	13.3	0.693
Master	Middle	0.9	0.514
Middle	Out	2.5	0.824
Middle	Bath	6.3	0.500
Bath	Front	2.0	0.612
Front	Out	6.6	0.677
Garage	Out	25.0	0.686



**Table B- 4. House 2 CONTAM Model Inputs**

Leakage Path		Power Law Coefficients	
From	To	C	n
Main	Out	64.7	0.676
Main	Master	15.2	0.6
Main	Middle	18.6	0.5
Main	Garage	16.2	0.327
Master	Out	4.5	0.54
Master	Middle	13.7	0.6
Middle	Out	0.22	1
Middle	Bath	2.40	0.61
Bath	Front	2.40	0.61
Front	Out	0.28	0.976
Front	Main	11.2	0.560
Garage	Out	50.7	0.671
Attic	Out	105.6	0.558
Attic	Main	30.0	0.534
Attic	Master	13.5	0.534
Attic	Middle	6.4	0.534
Attic	Bath	2.6	0.534
Attic	Front	6.6	0.534

Figure B- 1 and Figure B- 2 show screenshots of the CONTAM interface, showing airflow between each zone and the outside when no wind is included. In future work, the model will be run to simulate each of the PFT tests conducted, and the modeled concentrations of gas compared to those which actually occurred.

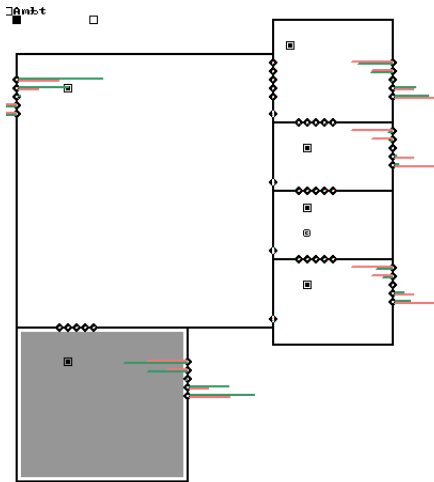

**Figure B- 1. CONTAM Model of House 1**

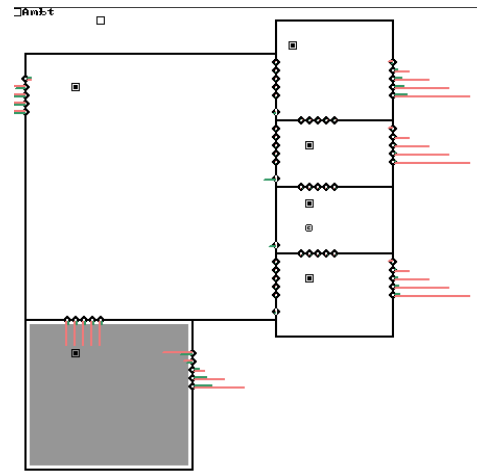

**Figure B- 2. CONTAM Model of House 2**

Specific leakage locations were not defined within each room, rather, diffuse leakage is assumed, but defined leak heights are required for calculating stack-driven flows. For each pair of adjacent zones, the leakage area was divided among five modeled leaks, spaced 2 feet apart vertically. This permits simultaneous bi-directional airflow between the zones. Townsend (2009) found that 5 leaks spaced this way in CONTAM approximate the condition of diffuse leakage. Under this assumption, the leakage areas in each room are symmetric about the neutral pressure plane. Therefore stack effect does not drive airflow between interior zones. The House 2 unvented attic is modeled, but not fully shown in Figure B- 2. Showing a summertime example condition, the unvented attic model shows outdoor temperatures warmer than indoor, when unvented attic airflow will be driven by stack effect infiltration into the attic and exfiltration from each occupied zone. The measured HVAC airflows will define the mechanically induced airflows. Weather data will be input to the model for boundary conditions.

### **B.3 Future Model Refinement**

The six tracer gasses used in the testing were input to CONTAM as separate contaminants. The time-dependant concentration of each tracer in each zone is calculated by CONTAM. The average concentration of each tracer as measured by the PFT samplers is calculated from these values in postprocessing.

As discussed previously, the fan pressurization testing did not directly measure every partition leakage area. Interior leakage of the bathroom and each bedroom was disaggregated for modeling. For this reason, and due to the limitations of fan pressurization testing for very low airflows, the initial leakage coefficients in the model are not expected to accurately reproduce the results of PFT testing. To improve the predictive value of the model, these uncertain leakage parameters will be adjusted. CONTAM will be called iteratively by a non-linear search algorithm, with the error between modeled and measured results being calculated after each run, and the input parameters improved.

Using all data for calibration would risk overfitting, that is, finding a model which only matches reality for the limited inputs used in calibration. Instead, some test data will be used in model

refinement, and the rest used to check the model. The methodology of ASTM D5157-97 will be used to assess the predictions of the model.

*buildingamerica.gov*

U.S. DEPARTMENT OF  
**ENERGY** | Energy Efficiency &  
Renewable Energy

DOE/GO-000000-0000 ▪ Month Year

Printed with a renewable-source ink on paper containing at least 50% wastepaper, including 10% post-consumer waste.

## **BA-1309: Ventilation System Effectiveness and Tested Indoor Air Quality Impacts**

### About this Report

This report was prepared with the cooperation of the U.S. Department of Energy's Building America Program.

Direct all correspondence to: Building Science Corporation, 30 Forest Street, Somerville, MA 02143.

### Limits of Liability and Disclaimer of Warranty:

Building Science documents are intended for professionals. The author and the publisher of this article have used their best efforts to provide accurate and authoritative information in regard to the subject matter covered. The author and publisher make no warranty of any kind, expressed or implied, with regard to the information contained in this article.

The information presented in this article must be used with care by professionals who understand the implications of what they are doing. If professional advice or other expert assistance is required, the services of a competent professional shall be sought. The author and publisher shall not be liable in the event of incidental or consequential damages in connection with, or arising from, the use of the information contained within this Building Science document.