

Job Name:

System Reference:

Date:

Indoor Unit:
PEAD-A18AA7

Outdoor Unit:
SUZ-KA18NAR1

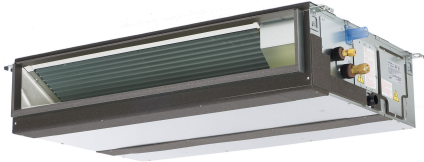

INDOOR UNIT FEATURES

- Unobtrusive ceiling-concealed design for short-run ductwork.
- Wide ranging external static pressure (0.14-0.60 in. WG)
- Built-in condensate lift mechanism (up to 27-9/16")
- Auto fan speed mode
- Optional FB Series filter boxes for easy access and service
- Ideal for residential homes, retail shopping centers, larger classrooms, office complexes, conference ballrooms, fitness centers, and more

OUTDOOR UNIT FEATURES

- Variable speed INVERTER-driven compressor
- Innovative Joint Lap DC Motor leads to high efficiency and reliability
- Pulse Amplitude Modulation technology
- High-performance grooved piping for increased heat exchange efficiency

SPECIFICATIONS: PEAD-A18AA7 & SUZ-KA18NAR1

Cooling ¹	Maximum Capacity	Btu/h	18,000
	Rated Capacity	Btu/h	18,000
	Minimum Capacity	Btu/h	7,500
	Maximum Power Input	W	1,440
	Rated Power Input	W	1,440
	Moisture Removal	Pints/h	3.20
	Sensible Heat Factor		0.80
	Power factor	%	97
Heating at 47°F ²	Maximum Capacity	Btu/h	24,700
	Rated Capacity	Btu/h	24,700
	Minimum Capacity	Btu/h	10,900
	Maximum Power Input	W	2,200
	Rated Power Input	W	2,200
	Power factor	%	97
Heating at 17°F ³	Maximum Capacity	Btu/h	14,000
	Rated Capacity	Btu/h	14,000
	Maximum Power Input	W	1,650
	Rated Power Input	W	1,650
Efficiency	SEER		18.8
	EER ¹		12.5
	HSPF (IV)		11.5
	COP at 47° F ²		3.20
	COP at 17° F ³		2.40
	ENERGY STAR® Certified (ENERGY STAR products are third-party certified by an EPA-recognized Certification Body.)		Yes
Electrical	Voltage, Phase, Frequency		208 / 230V, 1-phase, 60 Hz
	Guaranteed Voltage Range	V AC	187 - 253
	Voltage: Indoor - Outdoor, S1-S2	V AC	208 / 230
	Voltage: Indoor - Outdoor, S2-S3	V DC	24
	Voltage: Indoor - Remote Controller	V DC	12
	Recommended Fuse/Breaker Size	A	15
	Recommended Wire Size (Indoor - Outdoor)	AWG	14
Indoor unit	MCA	A	1.69
	Fan Motor Full Load Amperage	A	1.35
	Fan Motor Output	W	85
	Airflow Rate, Dry	CFM	424-512-600
	Airflow Rate, Wet	CFM	382-461-540
	External Static Pressure	in.WG	0.14-0.20-0.28-0.40-0.60
	Sound Pressure Level at 0.14 in. WG	dB(A)	30-33-37
	Drain Pipe Size	In. (mm)	1-1/4 (32)
	Condensate Lift Mechanism, Max. Distance	In. (mm)	27-9/16 (700)

SPECIFICATIONS: PEAD-A18AA7 & SUZ-KA18NAR1

	Heat Exchanger Type		Plate fin coil	
	External finish color		Galvanized	
	Unit Dimensions	W: In. (mm)		35-7/16 (900)
		D: In. (mm)		28-7/8 (732)
		H: In. (mm)		9-7/8 (250)
	Package Dimensions	W: In.		45-5/16
		D: In.		34-11/16
H: In.			13-7/16	
Unit Weight	Lbs. (kg)		62 (28)	
Package Weight	Lbs.		69	
Indoor unit operating temperature range	Cooling Intake Air Temp (Maximum / Minimum)	°F	90 DB, 73 WB / 66 DB, 59 WB	
	Heating Intake Air Temp (Maximum / Minimum)	°F	82 DB / 50 DB	
Outdoor Unit	MCA	A	14	
	MOCP	A	15	
	Fan Motor Full Load Amperage	A	0.93	
	Fan Motor Output	W	77	
	Airflow Rate	CFM	1,730 / 1,659	
	Refrigerant Control		LEV	
	Defrost Method		Reverse cycle	
	Heat Exchanger Type		Plate fin coil	
	Sound Pressure Level, Cooling ¹	dB(A)	54	
	Sound Pressure Level, Heating ²	dB(A)	56	
	Compressor Type		DC INVERTER-driven Twin Rotary	
	Compressor Model		SNB130FQBH	
	Compressor Rated Load Amps	A	10.0	
	Compressor Locked Rotor Amps	A	12.5	
	Compressor Oil Type // Charge	oz.	NEO22 // 15.2	
	External Finish Color		Munsell 3Y 7.8/1/1	
	Base Pan Heater		Optional (MAC-642BH-U1)	
	Unit Dimensions	W: In. (mm)		33-1/16 (840)
		D: In. (mm)		13 (330)
		H: In. (mm)		33-7/16 (850)
Package Dimensions	W: In. (mm)		40 (1,020)	
	D: In. (mm)		18-1/2 (470)	
	H: In. (mm)		39 (990)	
Unit Weight	Lbs. (kg)		119 (54)	
Package Weight	Lbs. (kg)		146 (66)	
Outdoor Unit Operating Temperature Range	Cooling Air Temp (Maximum / Minimum)	°F	115 / 14	
	Cooling Thermal Lock- out / Re-start Temperatures**	°F	-7 / -4	
	Heating Air Temp (Maximum / Minimum)	°F	75 / 12	
	Heating Thermal Lock- out / Re-start Temperatures**	°F	-7 / -4	

SPECIFICATIONS: PEAD-A18AA7 & SUZ-KA18NAR1

Refrigerant	Type		R410A
	Charge	Lbs, oz	3, 16
Piping	Gas Pipe Size O.D. (Flared)	In.(mm)	1/2 (12.7)
	Liquid Pipe Size O.D. (Flared)	In.(mm)	1/4 (6.35)
	Maximum Piping Length	Ft. (m)	100 (30)
	Maximum Height Difference	Ft. (m)	50 (15)
	Maximum Number of Bends		10

Notes

AHRI Rated Conditions (Rated data is determined at a fixed compressor speed)	¹ Cooling (Indoor // Outdoor)	°F	80 DB, 67 WB // 95 DB, 75 WB
	² Heating at 47°F (Indoor // Outdoor)	°F	70 DB, 60 WB // 47 DB, 43 WB
	³ Heating at 17°F (Indoor // Outdoor)	°F	70 DB, 60 WB // 17 DB, 15 WB

*Applications should be restricted to comfort cooling only; equipment cooling applications are not recommended for low ambient temperature conditions.

**System cuts out at -7°F (-21.7°C) to avoid thermistor error and automatically restarts at -4°F (-20°C).

ACCESSORIES: PEAD-A18AA7

Filter Box with MERV 13 Filters	□ FBM2-2
Wireless Signal Receiver	□ PAR-SA9CA-E
Wireless Signal Receiver	□ PAR-FA32MA-W
Wireless Signal Receiver	□ PAR-FA32MA-E
Wireless Remote Controller	□ PAR-FL32MA-E
Backlit, Wall-mounted, Wireless Controller	□ MHK1
Portable Central Controller	□ MCCH1
Wired MA Controller	□ PAR-33MAA
Simple MA Controller	□ PAC-YT53CRAU
Touch MA Controller	□ PAR-CT01MAU-SB
Airzone ZBS Wired Blueface Principal Controller White	□ AZZBSBLUEFACECB
Airzone ZBS Wired Think Controller White	□ AZZBSTHINKCB
Airzone ZBS Wireless Think Controller White	□ AZZBSTHINKRB
Airzone ZBS Wired Lite Controller White	□ AZZBSLITECB
Airzone ZBS Wireless Lite Controller White	□ AZZBSLITERB
Wired Remote Sensor	□ PAC-SE41TS-E
Wireless Temperature and Humidity Sensor	□ PAC-USWHS003-TH-1
Outside Air Sensor for MHK1	□ MOS1
Flush Mount Remote Temperature Sensor	□ PAC-USSEN001-FM-1
System Control Interface	□ MAC-333IF-E
Wireless Interface	□ PAC-USWHS002-WF-1
Thermostat Interface	□ PAC-US444CN-1
kumo station®	□ PAC-WHS01HC-E
USNAP Interface	□ PAC-WHS01UP-E
IT Extender	□ PAC-WHS01IE-E
BACnet® and MODBUS® Interface	□ PAC-UKPRC001-CN-1
External Fan / Heater Control Relay Adapter	□ CN24RELAY-KIT-CM3
Connector cable for remote display	□ PAC-SA88HA-EP
Connector for CN32 (remote on/off)	□ PAC-SE55RA-E
Lockdown Bracket for Hand-held Remote Controllers	□ RCMKP1CB
Remote Operation Adapter ¹	□ PAC-SF40RM-E
Blue Diamond Sensor Extension Cable — 15 Ft.	□ C13-103
MegaBlue Advanced Blue Diamond Condensate Pump w/ Reservoir & Sensor	□ X87-835 - 110 to 250V
Advanced Blue Diamond Mini Condensate Pump w/ Reservoir & Sensor (208/230V) [recommended]	□ X87-721 - 208/230V
Drain Pan Level Sensor	□ DPLS2
(30A/600V/UL) [fits 2" X 4" utility box] - Black	□ TAZ-MS303
(30A/600V/UL) [fits 2" X 4" utility box] - White	□ TAZ-MS303W

¹ Unable to use with wireless remote controller

ACCESSORIES: SUZ-KA18NAR1

Air Outlet Guide	□ MAC-886SG-E
Optional Defrost Heater	□ MAC-641BH-U
Outdoor Unit 3-1/4 inch Mounting Base (Pair) - Plastic	□ DSD-400P
Condensing Unit Mounting Pad 16" x 36" x 3"	□ ULTRILITE1
Outdoor Unit Stand — 12" High	□ QSMS1201M
Outdoor Unit Stand — 18" High	□ QSMS1801M
Outdoor Unit Stand — 24" High	□ QSMS2401M
Heavy Duty Wall Mounting Bracket— Coated Steel	□ QSWB2000M-1
Heavy Duty Wall Mounting Bracket — 316 Series Stainless Steel	□ QSWBSS
15' x 1/4" x 15' / 1/2" Lineset (Twin-Tube Insulation)	□ MLS141212T-15
30' x 1/4" x 30' / 1/2" Lineset (Twin-Tube Insulation)	□ MLS141212T-30
50' x 1/4" x 50' / 1/2" Lineset (Twin-Tube Insulation)	□ MLS141212T-50
65' x 1/4" x 65' / 1/2" Lineset (Twin-Tube Insulation)	□ MLS141212T-65
100' x 1/4" x 100' / 1/2" Lineset (Twin-Tube Insulation)	□ MLS141212T-100

DIMENSIONS: PEAD-A18AA7

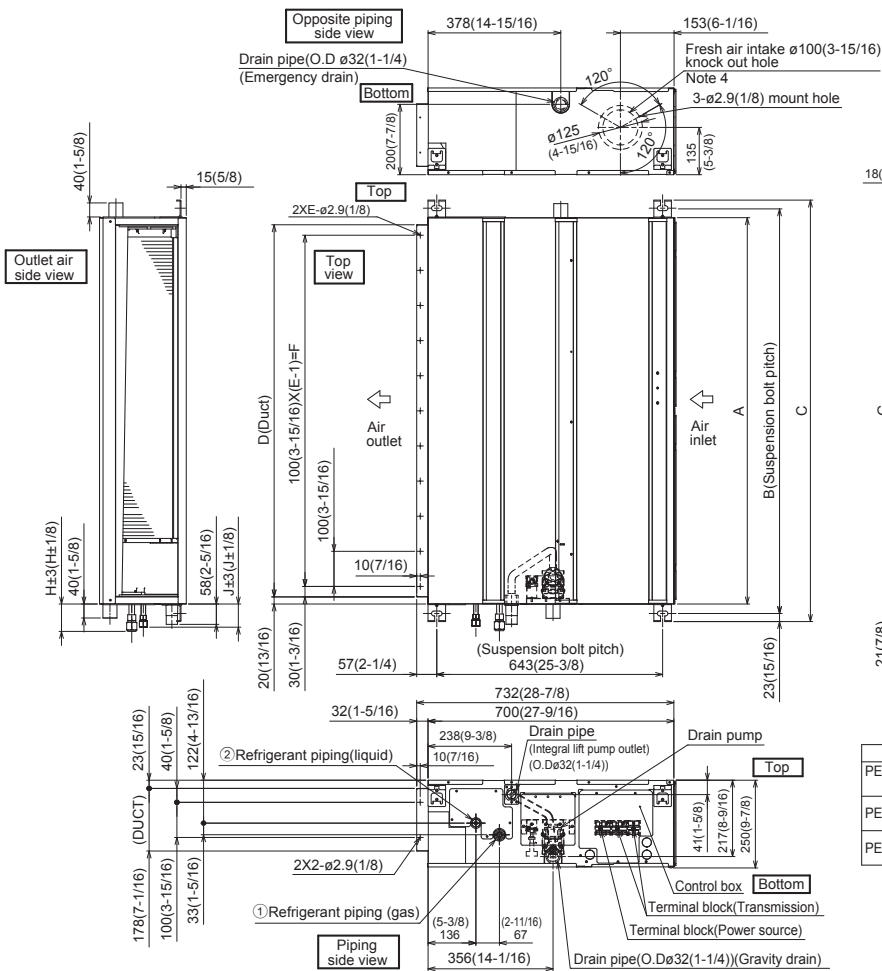

- Note 1. Use an M10 screw for the suspension bolt (field supply).
2. Keep the service space for maintenance at the bottom.
3. This drawing is for PEAD-A24·30·36·42 AA7 models, which have 2 fans. PEAD-A09·12·15·18AA7 models have 1 fan.
4. If the inlet duct is used, remove the air filter (supplied with the unit), then install the filter (field supply) at the suction side.
5. Heat air to 0°C (32°F) or higher when taking fresh air with a fresh air intake.

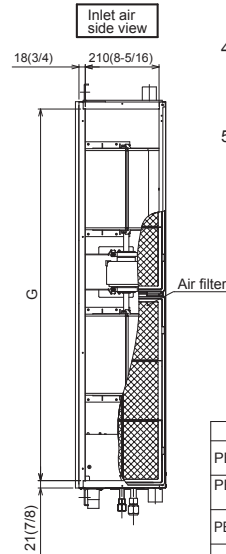

Unit:mm(in.)

Model	J	① Gas pipe	② Liquid pipe
PEAD-A09AA7	62 (2-1/2)	ø9.52 (3/8)	ø6.35 (1/4)
PEAD-A12,15,18AA7	62 (2-1/2)	ø12.7 (1/2)	ø6.35 (1/4)
PEAD-A24,30AA7	66 (2-5/8)	ø15.88 (5/8)	ø9.52 (3/8)

Unit:mm(in.)

Model	A	B	C	D	E	F	G	H
PEAD-A09,12,15,18AA7	900 (35-7/16)	954 (37-9/16)	1000 (39-3/8)	860 (33-7/8)	9	800 (31-1/2)	858 (33-13/16)	72 (2-7/8)
PEAD-A24,30AA7	1100 (43-5/16)	1154 (45-7/16)	1200 (47-1/4)	1060 (41-3/4)	11	1000 (39-3/8)	1058 (41-11/16)	78 (3-1/8)
PEAD-A36,42AA7	1400 (55-1/8)	1454 (57-1/4)	1500 (59-1/16)	1360 (53-9/16)	14	1300 (51-3/16)	1358 (53-1/2)	

DIMENSIONS: SUZ-KA18NAR1

Unit: inch

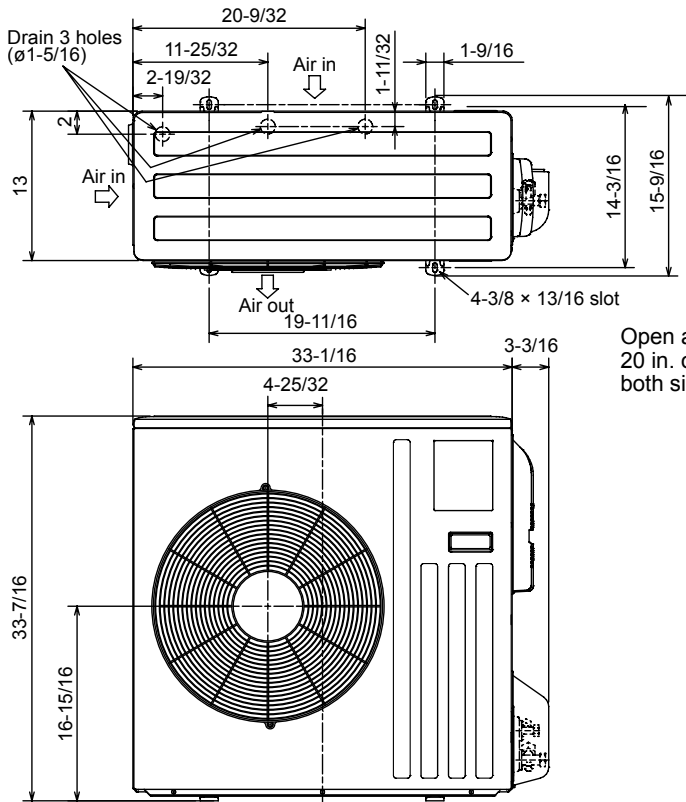

REQUIRED SPACE

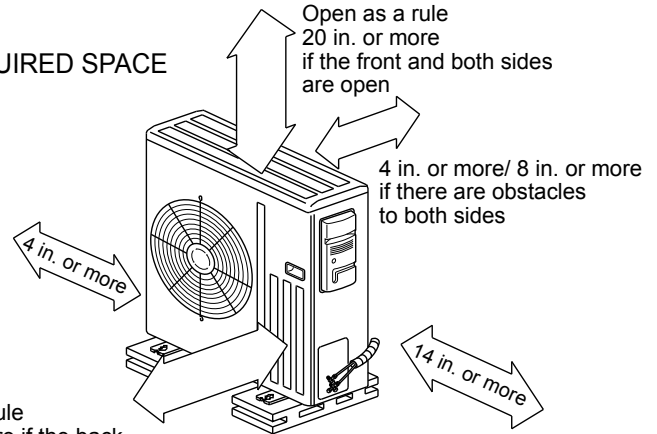

Open as a rule 20 in. or more if the back, both sides and top are open

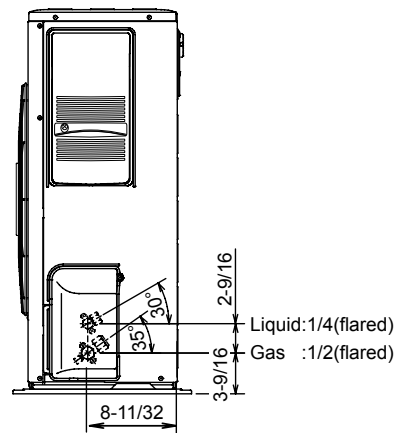

1340 Satellite Boulevard, Suwanee, GA 30024
Toll Free: 800-433-4822 www.mehvac.com

